

**DETAILED PROJECT REPORT  
MUNICIPAL SOLID WASTE MANAGEMENT  
PURULIA MUNICIPALITY**



**MAY 2017**





## ***Preface***

The urban solid waste problems are growing exponentially in the cities and urban centers of this country. Inadequate and inappropriate solid waste management policy is imposing threats on the environment, polluting the natural resources which in turn endangers the eco-system by large. It has reached disastrous proportions nowadays. The problem has become critical further for the reasons of lower socio-economic structures, inadequate resources, lack of techno management initiatives and community participation as a whole. Coupled with budgetary restrictions, poorly motivated staff, inadequate vehicles and implements the solid waste management has become one of the burning problems of the local bodies. The existing infrastructure is barely adequate to cope up with today's need.

This detailed project report, "Solid Waste Management System" for the Purulia Municipality has been prepared for improvement of the present solid waste management system of the town and also for proper surveillance and sustainability of the system. The report emphasizes upon the adequate steps for collection, transportation and processing through generation of energy & disposal of solid waste generated by the community. The total project cost is Rs. 1459.54 lakh. Per capita cost will be Rs. 1202.00. The most vital component of this project is the procurement of land in the near vicinity of the town and Purulia Municipality already has the land required in their possession. The project will be implemented and managed by Purulia Municipality with the technical assistance and guidance of Municipal Engineering Directorate.

Hope, this project will not only improve the environmental condition of the town and the health of the community, as a whole but will also fetch a good amount of revenue from the project.

*Thus waste to wealth.*

  
Shamim Dad Khan  
Chairman  
Purulia Municipality

# CONTENT

<b>Particulars</b>	<b>Pages</b>
Project Summary	
Introduction	1-3
Town Profile	4-8
Present Scenario of SWM System	9-11
Recommendations of Supreme Court Appointed Committee on SWM System	12-16
Collection of Waste	17-23
Transportation of Waste	23-25
Disposal of Waste	
✚ Waste Disposal Technologies	26-31
✚ Sanitary Land filling	31-38
✚ Design of the System	39-48
✚ Technical Specification of Bio Gas Plant	48-49
✚ Modified Sanitary Landfill	50-50
✚ Economics of the Project	51-54
Basic Ward wise Information	Annexure -I
Population Projection	Annexure – II - IIG
Table for Estimation of Domestic Waste	Table 10
Table for Estimation of Trade Waste	Table 11
Table for Estimation of Clinical Waste	Table 12
Estimation of Total Waste	Table 13
Requirement of Transfer Stations and Vehicles	Table 14
Abstract Cost Estimate	Table 15
✚ Detailed Estimate	Table 15A- 15F
Estimate for O & M Cost	Table 16-20
Recommendations	55-60
Directives	61-69
Public Private Participation	70-70
Time Schedule	-
EIA	-
Drawings	-



# SWM : PURULIA MUNICIPALITY

## PROJECT SUMMARY

POPULATION	:		121436	
AREA	:		12.90	SQ.KM
NO. OF HOLDINGS	:		32201	NOS.
NO. OF WARDS	:		23	NOS.
NO. OF DAILY MARKETS	:		4	NOS.
NO. OF COMMERCIAL CENTRES	:		0	NOS.
NO. OF HOTELS	:		17	NOS.
NO. OF HOSPITALS	:		3	NOS.
<b>QUANTITY OF WASTE</b>				
A) DOMESTIC WASTE	:		33.39	MT
B) MARKET WASTE	:		40.00	MT
C) HOTEL WASTE	:		0.44	MT
D) GARDEN/AGRICULTURAL WASTE	:		0.50	MT
E) TRADE WASTE	:		0.00	MT
F) OTHERS WASTE	:		2.00	MT
F) CLINICAL WASTE	:		1.15	MT
TOTAL QUANTITY OF WASTE	:		77.48	MT
<b>PROJECT COST</b>				
A) PLANT, MACHINERY, EQUIPMENTS FOR COLLECTION, TRANSPORTATIONS AND DISPOSAL	:	Rs.	381.29	LAKH
B) DEVELOPMENT OF LANDFILL SITE	:	Rs.	105.60	LAKH
C) CONSTRUCTION OF BIO-GAS PLANT	:	Rs.	930.15	LAKH
D) CONTINGENCIES	:	Rs.	42.51	LAKH
TOTAL PROJECT COST	:	Rs.	1459.54	LAKH
PROJECT PERIOD	:		2	YEARS
O & M COST PER YEAR	:		248.86	LAKH
<b>REVENUE</b>			<u>PER YEAR</u>	
TOTAL REVENUE GENERATION	:	Rs.	344.16	LAKH
O & M COST	:	Rs.	248.86	LAKH
SURPLUS (AFTER RE-PAYMENT OF LOAN, IF ANY)	:	Rs.	95.30	LAKH
<b>LAND REQUIRED</b>				
A) FOR SANITARY LANDFILL	:		2.4	ACRES
B) FOR BIOGAS PLANT AND OTHERS	:		0.6	ACRES
TOTAL LAND REQUIRED	:		3.0	ACRES

  
 Shamim Dad Khan  
 Chairman  
 Purulia Municipality



## **INTRODUCTION**

**S**olid Waste Management system involves activities associated with generation, collection, transfer & transport and processing and disposal of solid wastes generated by the community. It involves planning, organization, administration, finance, legal and engineering aspects involving interdisciplinary coordination. This aspect received scanty attention in most of the municipal towns resulting in insanitary conditions. An effective solid waste management scheme can be drawn by means of a harmonic integration between the available in house resources and the latest technologies.

Solid Waste Management is an obligatory function of Urban Local Bodies (ULBs) in India. However, this service is poorly performed resulting in problems of health, sanitation and environmental degradation. With over 3.6% annual growth in urban population and the rapid pace of urbanization, the situation is becoming more and more critical with the passage of time. Infrastructure development is not in a position to keep pace with population growth owing to the poor financial health of most of the urban local bodies. Solid Waste Management is one among the essential services, which suffers the most in such a situation. Lack of political will, inadequate financial resources, institutional weakness, improper choice of technology and public apathy towards Solid Waste Management has made this service far from satisfactory.

India has 4378 cities and towns as per 2001 census which comprises as under.

<b>Type of cities/towns</b>	<b>Population range</b>
<b>Above 1 million</b>	<b>35</b>
<b>Above 1 lakh</b>	<b>358</b>
<b>Above 50000</b>	<b>401</b>
<b>Below 50000</b>	<b>3584</b>
<b>Total</b>	<b>4378</b>

Waste generation ranges from 200 gms. to 600 gms per capita per day in cities ranging from 1 Lac to over 50 Lakh population. The larger the city, the higher is the per-capita waste generation rate. The total waste generation in urban areas in the country is estimated to exceed 100000 tons a day.

Indian mixed waste has a large proportion of compost able material and inerts. As per recent studies compost able matters are approximate 55% and inert materials 30 %. The component of recyclable material is between 15%.

A study of Indian cities has shown the Chemical Composition as under:

### Chemical Characteristics of Municipal Solid Waste in Indian Cities

Population Range (in millions) →	0.1 to 0.5	0.5 to 1.0	1.0 to 2.0	2.0 to 5.0	> 5
<b>Physical Characteristics</b>					
Paper (as %)	2.91	2.95	4.71	3.18	6.43
Rubber Leather And Synthetics (as %)	0.78	0.73	0.71	0.48	0.28
Glass (as %)	0.56	0.35	0.46	0.48	0.94
Metals (as %)	0.33	0.32	0.49	0.59	0.8
Total compostable matter (as %)	44.57	40.04	38.95	56.67	30.84
Inert (as %)	43.59	48.38	44.73	49.07	53.9
<b>Chemical Characteristics</b>					
Moisture (as %)	25.81	19.52	26.98	21.03	38.72
Organic matter (as %)	37.09	25.14	26.89	25.6	39.07
Nitrogen as Total Nitrogen (as %)	0.71	0.66	0.64	0.56	0.56
Phosphorous as P <sub>2</sub> O <sub>5</sub> (as %)	0.63	0.56	0.82	0.69	0.52
Potassium as K <sub>2</sub> O(as %)	0.83	0.69	0.72	0.78	0.52
C/N Ration	30.94	21.13	23.68	22.45	30.11
Calorific value* in Kcal/kg	1009.89	900.61	980.05	907.18	800.7

*Source: Manual on Municipal Solid Waste Management 2000- CPHEEO*

*\*Calorific Value on dry weight basis*

The prevalent SWM practices in the country are highly deficient. Generally no storage of waste is being done at source and instead, domestic, trade and institutional wastes, including bio-medical and industrial waste, are thrown on the streets, footpaths, drains and water bodies treating them as receptacle of waste. Recyclable waste material is also not segregated at source and is disposed of on the streets, along with domestic, trade and other wastes. Construction and demolition wastes also pose a serious problem as these wastes are also deposited on the roadside or open spaces, obstructing traffic and causing nuisance.

Generally no processing of waste is done in the country except in a few cities where decentralized or centralized composting is done on a limited scale. Here, the marketing of compost is posing a problem due to ineffective marketing mechanism. A few cities have recently attempted to set up waste to energy plant; their success is yet to be evaluated. Disposal of waste is done in a most unscientific manner. Generally crude open dumping is adopted for disposal of waste in low-lying areas. Most local bodies' deposits waste at the dump-yards without ascertaining the suitability of the land for waste disposal and do not bother to spread or cover the waste with inert material. These sites emanate foul smell, become breeding grounds for flies, rodent and pests, and pose a serious threat to underground water resources



and overall environment. System of waste management in the country is thus out-dated, unscientific and highly inefficient.

The laws governing the urban local bodies do not have adequate provisions to deal with the situation effectively officials dealing with SWM service do not have the necessary powers to punish defaulters. Filing of cases in the court for sanitation offences is cumbersome, takes a lot of time and energy of the staff and does not give the desired results as the punishment imposed at the end of long drawn proceedings is too small to have any salutary effect on the offender.

Looking to the deplorable situation of solid waste management in the country, public interest litigation was filed in the Supreme Court of India seeking direction to central government, state governments and city governments to manage the waste scientifically in an environmentally acceptable manner. Having realized the gravity of the situation, the Hon'ble Supreme Court constituted an expert committee to look into all aspects of solid waste management and make recommendation to improve the situation in class-1 cities.

The Committee so formed considered various options to improve solid waste management practices in these cities and, looking to the present state of SWM practices in urban areas in the country, the institutional capabilities of local bodies, their financial health and other priorities, recommended a minimum level of services that each local body must provide and gave technological options which the local bodies may consider while choosing the technology suitable for their cities, etc.

This Project Report is for identification of deficiencies and giving suggestions for development of a comprehensive Solid Waste Management System in Purulia Municipality as per the directives of Hon'ble Supreme Court and subsequent order No. 290/C-12/M/3S-1/97 Pt.V dated 6th January, 2005 of Department of Municipal Affairs, Govt. of West Bengal.

# TOWN PROFILE

## PURULIA

### **Background**

Purulia is the westernmost district of West Bengal with all-India significance because of its tropical location, its shape as well as function like a funnel. It funnels not only the tropical monsoon current from the Bay to the subtropical parts of north-west India, but also acts as a gateway between the developed industrial belts of West Bengal and the hinterlands in Orissa, Jharkhand, Madhya Pradesh and Uttar Pradesh.

Purulia town is the headquarters of the district Purulia.

Purulia is one of the most important towns in the western arid zone of West Bengal. Purulia municipality is one of the oldest municipalities of the state. The Year of Establishment is 1876 supported by no of villages and agricultural land.

### **Topographical/Geographical Parameters**

- i) Location : 23.28° north latitude and 86.24° longitude.
- ii) Elevation : 855 meters (on an average)
- iii) Area : 13.90 Sq. Km.
- iv) Population : 1,21,436 (as per Census, 2001)
- v) No. of wards : 23

The district Purulia lies between 22.60° and 23.50° north latitudes and 85.75° and 86.65° east longitudes. The geographical area of the district is 6259 km<sup>2</sup>. The district is bordered on the east by Bankura, Paschim Medinipur districts, on the north by Bardhaman district of West Bengal state and Dhanbad district of Jharkhand state, on the west by Bokaro and Ranchi districts of Jharkhand state and on the south by West Singhbhum and East Singhbhum districts of Jharkhand state. Gorgaburu is the highest peak of Ajodhya Hills at an altitude of **855 meters**. It is the highest point in southern part of West Bengal. It is located at Western plateau and highlands of Purulia district.

### **Communication**

The town is about 323 km away from the state capital Kolkata and is connected with important cities by both rail and road network. The south-eastern railway line crosses the town near its southern boundary from the north-east towards the south. NH 32 and NH60A pass through the heart of the town connecting Ranchi, the capital of Jharkhand and Jamshedpur. Barakar Road, a state highway, starts from the NH32 at the centre of the town and connects Barakar, Bankura and Durgapur towns of West Bengal.

The town is well connected with the rest of West Bengal and adjoining Jharkhand state. A major state highway passes through the town connecting N.H. and coal mines belt. The town is well connected by railways also.



This enjoys good communication with nearest railway station at Purulia, the bus service at every half an hour to connect every corner of the district and its adjoining areas. The Kolkata, the capital of this state is 230 km away and direct bus service is available from here.

### **Historical & Cultural Background**

The district Purulia has attained its present status after undergoing massive changes in the territory over decades from what was known earlier as Vajra Bhumi.

From archaeological surveys and the relics and the inscriptions (Jaina Bhagavati-Sutra), which have been deciphered till date, Purulia is known to be existing even in the circa 5th century A.D. as a significant part of the territory of 16 Mahajanapadas. The ancient history of Purulia was depicted with the name Vajra-Bhumi. Vajra-Bhumi (present Purulia), in the medieval times includes the whole part of present state of Jharkhand.

Vajra -Bhumi has passed through several hands, has underwent massive change and the whole district has continued to exist as fragmented sections controlled by several kings. Finally the entire territory of Bengal came under the Muslim sway in 1365, when the Afghan Chief Bakhtiyar Khalji ousted the last Sena King Lakshman Sena from Bengal. Bengal reached its culmination in the Sultanate régime, who consolidated the disintegrated portions of Bengal and established a separate territory. Following the ancient chronicle accounts of Purulia it was under these Subha or the Sultans, the broken fragments of Purulia and other parts of Bengal were united.

In the year 1765, demolishing the last sovereign king of Bengal Siraj-ud-daulah in the battle of Plassey, the British take over the sovereignty of Bengal. The recorded history of Purulia begins with the suzerainty of the British in the entire tract of Bengal. The British finally attained the grant of Diwani of Bengal, Bihar and Orissa. In 1805, by Regulation of XVIII, the British formed a new district called "Jungle Mahals", incorporating 23 Parganas and Mahals, including the present Purulia. In 1833 jungle Mahals was again disintegrated and a new district "Manbhum" was constituted with its headquarter at Manbazar. Manbhum was a vast district including the areas of Bardhaman & Bankura of present West Bengal and Dhanbad, Dhalai, Sarikela and Kharswan of present Jharkhand.

As the history of Purulia depicts, in 1838, the district headquarter was shifted to present Purulia for administrative convenience. Since Purulia was been recognized as the district headquarter of Jungle Mahals, it was withdrawn from the direct administration and placed under the intervention of the delegates of the British Raj. An officer called Principal assistant to the agent of the Governor General to the South West Frontier ruled Purulia. The abrupt alteration and the rapid changes continue to illustrate the history of Purulia even after independence and partition of Bengal. Finally with the act of Transfer of Territories in 1956, the district of Manbhum was separated between Bihar and West Bengal and the present district of Purulia was born out of that separated tract of Manbhum on 1st November 1956.

The Municipality is divided into 23 wards covering 13.90 square kilometers, with population of 121,436 as per 2011 census, out of which 28.22% live in the slums.

## OCCUPATIONAL PATTERN AND ECONOMIC BASE:

**a).Industry:** Hand loom industries take very important part in his town. There are good no. of weavers who are emerged in such industries. Silk/ Tasar product of Purulia has earned acclaim at national level. There are several weavers co-operatives also located within the town.

**b).Economic Activities:** The town is a good service centre for agriculture products. A considerable endeavor is being made for improvement in primary sector like cottage industries, handloom, finishing and poultries.

## SOCIAL INFRASTRUCTURE:

**a).Health Facility:** There is one Sub-Divisional Hospital in this town though the district hospital is nearer to this town with quite accessible with indoor, outdoor and bed facilities.

**b).Educational:** Educational facilities is not so remarkable in this town.

**c).Post & Telegraph:** There is a Sub-Divisional post office at Purulia Municipality as well as a Telephone Exchange.

**d).Banking facilities:** It is available to meet the present needs.

**e).Recreation:** According to requirement the park and playground and cinema hall are more or less available here.

**f).Culture**

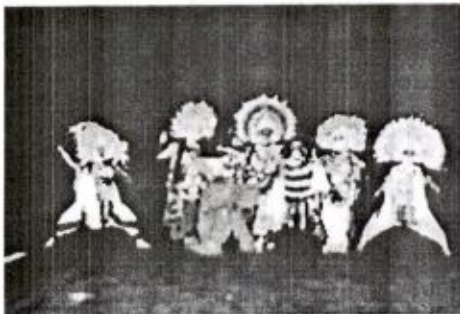

The culture in Purulia concentrates on the traditional folk dance "Chhou". The uniqueness of this rare mask dance of eastern India lies in the fact that it is the dramatic representation of everyday life of the common people on stage. There are several categories of this Chau culture. However the antiquity of Purulia's local culture traced back to 12-14th century A.D. when the small pockets of present Purulia was inhabited by the hostile tribes. Some Hindu chieftains, so far the historical records are concerned established their sovereignty in the region. With the passing of days their culture was synchronized with the local culture of the tribals and that coordinated culture have become modified into the present day "Chhou dance". Apart from the Chhou culture different layers of influence, which have been accumulated for ages, is discernible in the folk culture and the human behavior and the nature and style of living.

Presently the Chhou dance of Purulia has attained an international publicity. The Chhou dance is an inseparable part of the rituals and the festivals occasioned in Purulia. The Chhou dance, always followed by the ritual in the nearby Shiva temple is significant enough. The folk culture of Purulia is invested with ritualistic significance of the land.



### **g).Tourism in Purulia**

Purulia is an ideal place for tourists. The undulating topography, calm serenity and nature with its prolific abundance, silence of dense forests, twittering of birds and wild life, beautiful flora and fauna, picturesque hills and hillocks, falls, rivers, rivulets and streams make this place attractive to the visitors. Thousands of tourists come to visit Purulia every year to witness the charm of the natural forests of Ayodhya, Matha and Kuilapal, falls and tribal habitations of Ajodhya Hills and Bagmundih, dams like Panchet, Murguma and Futari, heritage building like Panchakot Raj Palace, trekking range of Matha proud with Pakhi Pahar, and Joychandi Pahar, picnic spots like Duarsini, Doladanga, Jamuna, traditional folk dance and culture like Chhou Dance and Jhumur Song and so on. Purulia district is well connected by road and rail with the major cities and towns of the state as well as of the country. For its convenient location, this place has acquired an important place in the tourist map in India.

The tourism of Purulia centers round the archaeological excavations and the relics of the ancient buildings and the temples. Purulia is recorded as the oldest place in West Bengal, existed even in the 5th century A.D and used to be an important center of the 16 Mahajanapadas. Hence the tourism industry of Purulia has more to offer to the lovers of ancient culture and the historians.



The village Banda is a famous name as a tourist spot in Purulia. The prime attraction of the village is the solitary temple build in the "rekha" style, with broken amalaka. The base moldings and the exquisite floral fabrications throughout the outer and the inner sections of the temple walls cast a spell to the tourists.

The big village Cheliama has a profitable contribution to the tourism industry of Purulia. The remnants of the contemporary civilization of 17th century have endowed the village with rich historical interest. The terracotta figurines and the exclusive carvings around the temples of Cheliama, murmurs the prosperity of the terracotta architecture in Purulia in the 17th Century. The famous temple, which attracts a mass of tourist to it, is the Radha-Govinda Temple, which is the plaque of the Bengali Culture prevalent in the contemporary era.

Deulghat, as its name suggests is the land of temples. It has the ruins of 15 temples near the Kansai River. The stucco decoration is the notable architecture made on the temple. The entrance of those temples is entangled with the branches of trees, casting an eerie. However these temples are the representations of the age, when they were built. Moreover the temples adorned with the graceful carve, attracts visitors, and hence are important in the tourism of Purulia.

The temples are usually stone-made which indicates that the sculpture on the stones was the traditional culture of the contemporary people. Although the buildings of the temples of Pakbirra have ruined and nothing

but the relics is left, it still continues to be an important tourist center. According to the surviving remnants, those temples are built following the Jaina tradition, once prevalent in Purulia.

A number of iron images are found in the eroded temples of Suissa and in the adjoining regions. The ionic images mainly include the mythological gods and the goddesses in an unusual pose.

Muslim relics are found in the village called Para. However the archaeological relics and the eroded temples have a beauty of their own kind, which helps the tourism industry of Purulia to a large extent.

### **PHYSICAL INFRASTRUCTURE**

**a).Road System:** Out of different types roads according to importance, most of the roads require improvement to meet the present needs.

- i. Metal Road – 10.20 km
- ii. Concrete Road – 23.90 km.
- iii. WBM Moorum- 8.25 km.
- iv. Kutchha – 10.50 km.

**b).Drainagr System:**Here is no underground drainage system. The stretch of pucca drain is 16.95 km whereas the kutchha drain is about 9.50 km.

**c).Housing Facilities:**People generally dwell in their own or rental houses either pucca or kutchha. Out of those 150 nos homeless were provided houses under NSDP & IYSH

**d).Commercial Activities:** It own business center for both agricultural and cottage industrial products and for day to days requirement. There is no major industry in the town. There is one municipal market with about 294 shops. Total number of shops in the town is 2,200.

**e).Sewerage and Conservancy:** There is no vital factor to construct sewerage system. The municipality maintains a proper garbage cleaning and drain cleaning arrangements.

**f).Electricity Facility:** The Municipality has provided street lights for the 45% roads, more than 85% of the house holds are with electricity connection.



## **1.0 PRESENT SCENARIO OF SOLID WASTE MANAGEMENT SYSTEM IN WEST BENGAL**

### **1.1 SOLID WASTE MANAGEMENT SYSTEM**

The state of West Bengal witnessed significantly high level of Urbanization during the decades of seventies and eighties. The urban population in West Bengal was estimated as 27.39% of the total population in the 1991 census report as against 25.70% for the entire country. In terms of density of urban population, West Bengal is much ahead of other states. The over all density of urban population in West Bengal in 1990-91 was estimated as 6207 individuals per square kilometer against the national average of 4098.

While the urban towns in West Bengal have rapidly increased in terms of activities and population, the municipal services available at these urban centers are yet to reach the adequate level. Solid wastes in the urban areas are generated from a multitude of sources out of domestic, commercial, institutional & industrial activities. If these wastes are not stored, collected, hauled and disposed off safely and timely, the same cause aesthetic problems and severe impact upon the public health, by means of pollution of air, soil and natural water sources. Therefore Solid Waste Management (SWM) is one of the crucial civic services, without which no pollution abatement measure can be full proof and sufficient. Although SWM is the single largest item of expenditure in the municipal budge, this service suffers from critical deficiencies.

In the wake of fast growing environmental consciousness and increasing public health problems, the concern in respect of inefficient SWM has metamorphosed into an alarming situation, which has inspired the urban local bodies to look for appropriate cost effective technology along with fiscal support.

The different components of the SWM for a particular town can be designed in a no. of ways depending on local conditions e.g. climate, waste characteristics, urban structure, transport economics and desired level of services.

### **1.2 EXISTING INFRASTRUCTURE & DEFICIENCIES**

At present there is no National or State Plan for an integrated approach to deal with the Solid Waste Management System. In the matter of financial resources, the small and medium municipalities are much weaker / compared to the bigger municipalities. The bigger municipalities employ 5 staff per 1000 population, whereas the small and medium municipalities can hereby employ 2 to 3 staff per 1000 population.

### **1.3 SOLID WASTE CHARACTERISTICS**

Community produces variety of wastes ranging from metal to textile produces and from ash to vegetable produces which have different physical and chemical composition. Apart from that, industrial and medical wastes used to get mixed up with municipal wastes frequently, which are usually disposed off indiscriminately without any special treatments.

The average properties of solid waste based upon past studies may be predicted as per following :

Table-1

<u>Character</u>	<u>Contents</u>	<u>Percentage</u>
<b>Physical :</b>		
(i)	Earth & Ash Content	: 48%
(ii)	Fermentable	: 37%
(iii)	Stones & non-degradables	: 12%
(iv)	Density	: 560 to 600 kg/cu.m.
(v)	Calorific value	: 800 to 980 kcal/kg.
<b>Chemical :</b>		
(i)	Moisture	: 45%
(ii)	P <sup>H</sup> value	: 6.80
(iii)	Nitrogen	: 0.5%
(iv)	Phosphorus	: 0.52%
(v)	Potassium	: 0.50%
(vi)	Organic matters	: 38%
(vii)	Carbon	: 20%
(viii)	C / N ratio	: 40

#### **1.4 QUANTUM OF SOLID WASTE**

The quantum of Waste generation depends upon the size of the town as well as its, socio-economic conditions. However, it was estimated that the generation of solid waste range from 200 to 600 gms. per capita per day depending upon the category, size and nature of activities in the town.

#### **1.5 STORAGE AND COLLECTION**

##### **1.5.1 Existing Solid Waste Management**

At present the refuse in municipal areas is disposed by uncontrolled dumping at places wherever low land is available. Landfill sites do not conform to any long term regional land use planning. Garbage removal is done only on intervals and there is always some accumulation of garbage on road side. Operational control for environmental protection and control of fly breeding is inadequate. Covering and compaction are not practiced.

##### **1.5.2 Primary Collection**

Primary collection starts at the household or at the community facilities. In all the municipal towns under consideration, house collection is almost non-existent and community facilities are scarcely provided. Practically none of the municipal bodies collects solid waste regularly from all areas except from market areas. The existing methods of garbage collection consists of following operation: i) Street sweeping, ii) Collection of road side garbage heaps and sweeping into box type hand carts or wheel barrows, iii) unloading the hand carts into bigger garbage vats or into bigger heap sites on main road.

##### **1.5.3 Secondary Collection & Transfer**

This particular activity in solid waste handling in municipal bodies involve picking up manually from the dumps of solid waste and loading into conservancy trucks / trailers. This results in wastage of labour and time for vehicles apart from the health risks of the workers and public at large, which are also exposed to



danger of contamination of ground water, which is the main source of drinking water in most of the municipal bodies. In some small and medium towns, tractor-trailer system is being used extensively for transportation and in some small towns animal carts are also employed.

In most cases, the design of transportation vehicle is not appropriate and also not conducive to labour and vehicle productivity. The trucks which are used for transportation of the garbage to the dumping ground are found to be very inconvenient because (i) Excessive loading height of the trucks making manual loading difficult, (ii) they can not carry more than 3-4 tons of garbage due to its low density and high bulkage (iii) Excessive wear and tear of the body due to corrosive nature of the garbage (iv) Idle time lost in loading of the trucks.

#### **1.6 DISPOSAL**

More than 90% collected solid wastes in most of the municipal towns are disposed by filling up low lands scattered within the municipal areas in an uncontrolled, haphazard and insanitary manner which is a potential health risk for the community. Orthodox type composting in few towns is also practiced.

#### **1.7 DEFICIENCIES AND SHORT COMINGS IN THE PRESENT SYSTEM**

The overall picture of solid waste management in the municipal towns is not quite satisfactory and needs to be improved in order to achieve proper environmental sanitation. The basic short-comings and problems associated with solid waste management in municipal towns are as follow :

1. Population explosion, uncontrolled urbanization, slum area proliferation.
2. Socio-economic crisis (huge external debt, economic austerities, prolonged recession, high rate of inflation, high rate unemployment, social disorder, etc.)
3. Accelerated and uncontrolled generation of municipal wastes and industrial hazardous wastes.
4. Negligence and lack of interest for an effective solid waste management plan.
5. Insufficient public education and limited community participation.
6. In appropriate design of primary handcarts and collection vehicles causing multiple handling of waste and environmental problems.
7. The small and medium municipalities are lacking considerably in the servicing and workshop facilities for the mechanical transport fleet.
8. The location of disposal grounds and their sizes are not decided on the basis of optimum haulage and rotational transportation routing.
9. Disposal of solid waste by land filling method is not generally carried out in a proper sanitary method.
10. Regular analysis and monitoring of solid waste characteristics are not done and presence of toxic and hazardous materials cannot be ruled out.

## **2.0 RECOMMENDATIONS OF THE SUPREME COURT APPOINTED COMMITTEE FOR MODERNIZATION OF SOLID WASTE MANAGEMENT PRACTICES ARE BRIEFLY AS UNDER**

### **☆ Ban on Throwing of Wastes on the Streets**

No waste shall be thrown on the streets, footpaths, open spaces, open drains or water bodies.

### **☆ Storage of waste at source**

Waste shall be stored at source of generation in 2 bins/bags, one for food/bio-degradable wastes and another for recyclable waste. Domestic hazardous waste, as and when produced, shall be kept separately from the above two streams.

Multi storied buildings, commercial complexes and group housing shall additionally provide community bins for storage of waste generated by their members. Community bins shall also be provided in slums by the local body for the community storage of waste by slum dwellers.

### **☆ Doorstep Collection of Waste**

Both the streams of waste, organic/ bio-degradable waste as well as recyclable waste shall be collected from the doorstep. Containerized handcarts or containerized tri-wheel cart or small-motorized vehicles shall be used for daily collection of food/ bio-degradable waste from the doorstep through public participation using a bell, whistle or horn as a means of announcing the arrival of the collection staff.

For collection of recyclable waste from the doorstep NGOs may be encouraged to organize the rag pickers. They may allot them the work of collection of recyclable material from the doorsteps instead of picking it up from the streets, bins or dump-yard, thereby upgrading their status. This waste can be collected once or twice a week according to the convenience of the households, shops or establishments.

Hazardous toxic waste material, which is occasionally generated, shall however be disposed of by the citizens in special bins to be provided in the city at suitable locations by the urban local bodies.

### **☆ Sweeping of Streets on All Days of the Year**

Sweeping of streets and public places having habitation or commercial activities on one or both sides shall be done on all days of the year irrespective of Sundays and public holidays. Arrangements for rotating weekly rest-days are to be made by the local bodies.

### **☆ Work Norms for Sweeping of Streets**

Work norms ranging from 250 to 750 running meters of road length have been recommended, depending on the density of the area and local conditions. Giving a demarcated "pin point" area for street sweeping and waste collection is also recommended for optimum utilization of manpower.

### **☆ Provision of Litterbins at Public Places**

Provision of litterbins at railway stations, bus stations, market places, parks, gardens and important commercial streets may be made, to prevent littering of streets.



☆ **Abolition of Open Waste Storage Sites and other Un-hygienic Street Bins**

The pathetic condition of street bins must be corrected by the provision of neat mobile closed body containers into which waste can be directly transferred from the containerized hand carts or tri-wheel cart and all open waste-storage sites as well as cement concrete or masonry bins must be abolished in a phased manner.

☆ **Transportation of Waste to Synchronize with Waste Storage Facility - Dispense with Manual Loading of Waste**

For the transportation of waste, a system which synchronizes with both primary collection and bulk waste storage facilities may be introduced. Manual loading and multiple handling of waste may be dispensed with and instead, hydraulic vehicles for lifting the containers may be used in larger cities and tractor trolleys or a tractor container combination may be used in smaller cities.

Transportation of waste shall be done on a regular basis before the temporary waste-storage containers start over-flowing. For economy in expenditure, the vehicle fleet should be used in at least two shifts. Workshop facilities may be optimized to keep at least 80% of the vehicle fleet on road. Transfer stations may be set up in cities where the distance to waste-disposal sites is more than 10 Kms.

☆ **Processing And Disposal Of Waste:**

**Conversion of Organic Waste / Bio-degradable Waste into Bio-organic Fertilizer (Compost)**

With the availability of land for processing and disposal of waste becoming scarce and the food and bio-degradable component useful to agriculture going waste, measures for conservation of land and organic waste resource shall be taken and Organics shall be returned to the soil. To meet these objectives, all food waste and bio degradable waste shall be composted, recyclable waste shall be passed on to the recycling industry and only rejects shall be land filled in a scientific manner. Decentralized composting with public and NGOs/CBO participation, may be encouraged wherever possible, and centralized composting of the rest of the waste may be done. Microbial or vermi composting processes may be adopted. A variety of composting options has been given in the report and their processes are explained.

☆ **Caution Against Using Unproven Technologies**

Local bodies are cautioned not to adopt expensive technologies of power generation, fuel polarization, incineration etc. until they are proven under Indian conditions and the Government of India or expert agencies nominated by the Government of India advises cities that such technology can be adopted.

☆ **Land To Be Made Available On Priority For Processing And Disposal Of Waste**

Availability of land for setting up processing plants and for disposal of waste is a major problem faced by urban local bodies. Government wasteland must therefore be given on top priority for this purpose free or at nominal cost, and if such land is not available or not found suitable, private land should be acquired or

purchased through negotiated settlement. A Committee at the district level should identify suitable land and State Governments should form Empowered Committees to give speedy final clearance and prompt possession of suitable land to the ULB.

☆ **Criteria for Site Selection, Site Development and Landfill Operations**

Criteria for site selection, development of land fill sites and scientific landfill operations may be adopted. Remediation of old abandoned landfill sites should also be done as suggested in the detailed report. Bio-medical waste, industrial waste and slaughterhouse waste may be managed as per the relevant Rules and guidelines of the Government of India and/or Central Pollution Control Board.

☆ **Institutional Strengthening and Capacity Building**

Institutional strengthening is the key to success of the SWM system. Professionalism in administration, decentralization of administration, delegation of financial and administrative powers, induction of environmental/public health engineers in the solid waste management services and fixation of work norms and proper supervisory levels are recommended. Human resource development through training at various levels needs to be taken up.

☆ **NGO/Private sector Participation in SWM Services**

There is a need to improve accountability and the level of services through NGO/Private sector participation in SWM services to improve overall performance without harming the interests of the existing staff.

☆ **Enforcement**

A system of levy of administrative charges or special cleaning charges from those who litter the streets or cause nuisance on the streets may be introduced and powers to punish offenders may be given to the local bodies through suitable additions to the Municipal acts & rules.

☆ **Management Information System**

MIS is the key to monitoring the performance of manpower and machinery and to help in planning for the future. Detailed management information systems should be introduced.

☆ **Financial Aspects**

The poor financial health of ULBs is major constraint in improving SWM systems. The financial condition of local bodies may first be improved by setting the house in order and a series of measures towards financial discipline, avoidance of wasteful expenditure, prioritizing the expenditure on essential services, as recommended in the report may be taken. Taxes, user charges and fees should be raised and linked to the cost-of-living index. Area-based property-tax reforms may be taken up to improve the finances of the ULBs.



### ☆ Health Aspects

Improper SWM practices give rise to problems of health and sanitation. Twenty-two types of diseases are associated with improper SWM practices. Proper management of processing and disposal sites, special attention to cleaning of slums, provision of low cost sanitation facilities to prevent open defecation, prevention of cattle nuisance, proper training to the workforce and use of protective clothing are some of the measures the local body should take immediately to protect the health of the citizens and the workforce.

### ☆ Legal Aspects

Citizens' active participation may be ensured through massive public awareness campaigns. Simultaneously, adequate provisions may be made in local State laws governing the local bodies to ensure public participation and action against defaulters. Legislative provisions to be made by each State have been suggested in the report.

### ☆ Public Awareness Strategy

Public awareness campaign using information, education and communication (I-E-C) techniques may be used. Waste Reduction, Reuse, Recycling (R-R-R) may be advocated to reduce the burden on the local body and citizens may be motivated to store waste at source in a two-bin system, co-operate with the doorstep primary collection system and keep the city litter-free. Hygienic Solid Waste Management needs to find a place in the National Agenda.

### ☆ NGO, Public and Private Sector Participation.

Supreme court committee has laid emphasize on active involvement of non-governmental organizations (NGOs) in creating awareness among the people, in organizing the rag pickers for collection of recyclable material and in organizing door step collection from households, shops and establishments.

A lot of emphasizes is to be given on public participation, without which no system would ever succeed. Public participation in the area of storage of waste at source, & at the community level and in the primary collection of waste is highly advocated and insisted upon. Legal provisions are also suggested to take action against the citizens if they fail to comply in spite of repeated instructions through awareness campaign to cooperate in the system.

Private sector participation is the key to success in the areas where higher technologies are involved and where personalized services are proposed to be given. With ever increasing cost of manpower and relatively lower efficiencies of public sector undertakings, it has been strongly recommended that private sector should be involved in the area of door step collection of waste *from hospitals, nursing homes, hotels, restaurants, commercial complexes, households, etc. as well as in the area of transportation of waste and setting up solid waste treatment and disposal facilities in the urban areas.*

## **2.1 ISSUES TO BE ADDRESSED**

The following issues need to be addressed during policy formulations.

- i) Effective public participation in segregation of recyclable waste and storage of waste at source.
- ii) Public participation in primary collection of waste
- iii) Sweeping of streets and primary collection of waste on all the days of the year irrespective of Sundays and public holidays.
- iv) Provision of closed body mobile waste storage depots and abolition of open waste storage sites.
- v) Safe and separate storage as well as doorstep collection of biomedical waste, hotel and restaurant waste, yard waste, etc., on full cost recovery basis.
- vi) Avoid the need of multiple handling of waste through the adoption of principal of "handle waste once only" in the matter of collection, transportation and disposal of waste.
- vii) Transportation of waste on day to day basis in closed body vehicles.
- viii) Processing of waste for generating compost, power and other useful products.
- ix) Disposal of waste in an environmentally acceptable manner through establishment of sanitary landfill sites.
- x) Grant of land for processing and disposal of waste.
- xi) Institutional strengthening and human resources development.
- xii) Institutional strengthening and human resources development.
- xiii) Introducing element of cost recovery.
- xiv) Encouraging private sector participation in waste management
- xv) Welfare of the staff engaged in solid waste management services.
- xvi) Creation of public grievances redressal mechanism.
- xvii) Provision for enforcement of sanitation laws and rules.

## **2.2 SCOPE OF THIS REPORT**

This report will deal with Solid Waste Management System of the town **Purulia** in the district of Purulia of West Bengal. The objective of this report is to analyze the present situation and recommend for "**Planning and Development of Modernized Practices for Sustainable Solid Waste Management System in the Purulia Municipality of West Bengal**"

The following chapters will discuss about the appropriate technology and methodology for handling, collection, transportation, processing & final disposal of municipal solid waste and also design a comprehensive Solid Waste Management System for Purulia Municipality. The necessary recommendations and directions are also furnished below.

This project report is prepared by Municipal Engineering Directorate, Govt. of W.B., as per the request of Municipal Authority for compliance of Govt. order.

### **3.0 COLLECTION OF WASTE**

#### **3.1 DEVELOPMENT OF POLICIES AND CHOICE OF APPROPRIATE TECHNOLOGY AND METHODOLOGY**

The success of any solid waste management system largely depends upon the three factors (i) Collection, (ii) Transportation & iii) Disposal. So, to make success clear assessment on the quantity of solid waste to be handled is very much essential. In respect of Purulia town a figure of 275 gm/cap/day is fairly reasonable for consideration. The variety of solid waste generally generate in a Municipal town are domestic, market, trade, Hospital / Clinical Waste in nature. Waste from street sweepings, sewer line cleanings and construction debris etc. also get into the access with the main waste.

With a view to improve upon the present collection, transport and disposal methods in the municipality, future solid waste management works are to be carried out on the basis of the principles stated below.

Cost of transportation is one of the major components of solid waste management system. Routing and scheduling of vehicles are of prime important from economic point of view. For convenience and economic consideration of as collection and transportation of solid waste the whole Purulia municipal area may be divided in four zones as given in the following table.

**Table No. - 2**

<b>ZONES</b>	<b>AREA &amp; WARD NOS.</b>
<b>Zone A</b>	1,2, 3, 4, 5, 20, 23
<b>Zone B</b>	6, 7, 8, 9
<b>Zone C</b>	10, 12, 13, 14, 15,17,18,19
<b>Zone D</b>	11, 16, 21, 22

#### **3.1.1 Collection**

The local body shall be the responsible for the arrangement for the collection of waste stored at various sources of waste generation on a daily basis. This shall be done by any of the following methods or combination of more than one method:

- i) The garbage is to be suggested to be separated in accordance with their classes at the point of generation. This practice will help to dispose off the garbage effectively at the dumping ground, as well as reduction of massive handling activities of the cumulated garbage mass at a centralized point.
- ii) The garbage is suggested to be containerized at the point of generation. This will not only help to reduce the collection time but will also reduce the health hazards. Therefore the service level will be better.
- iii) Door-step collection of domestic waste through handcarts or similar other devices with active community participation.



## FLOW CHART FOR SWM SYSTEM

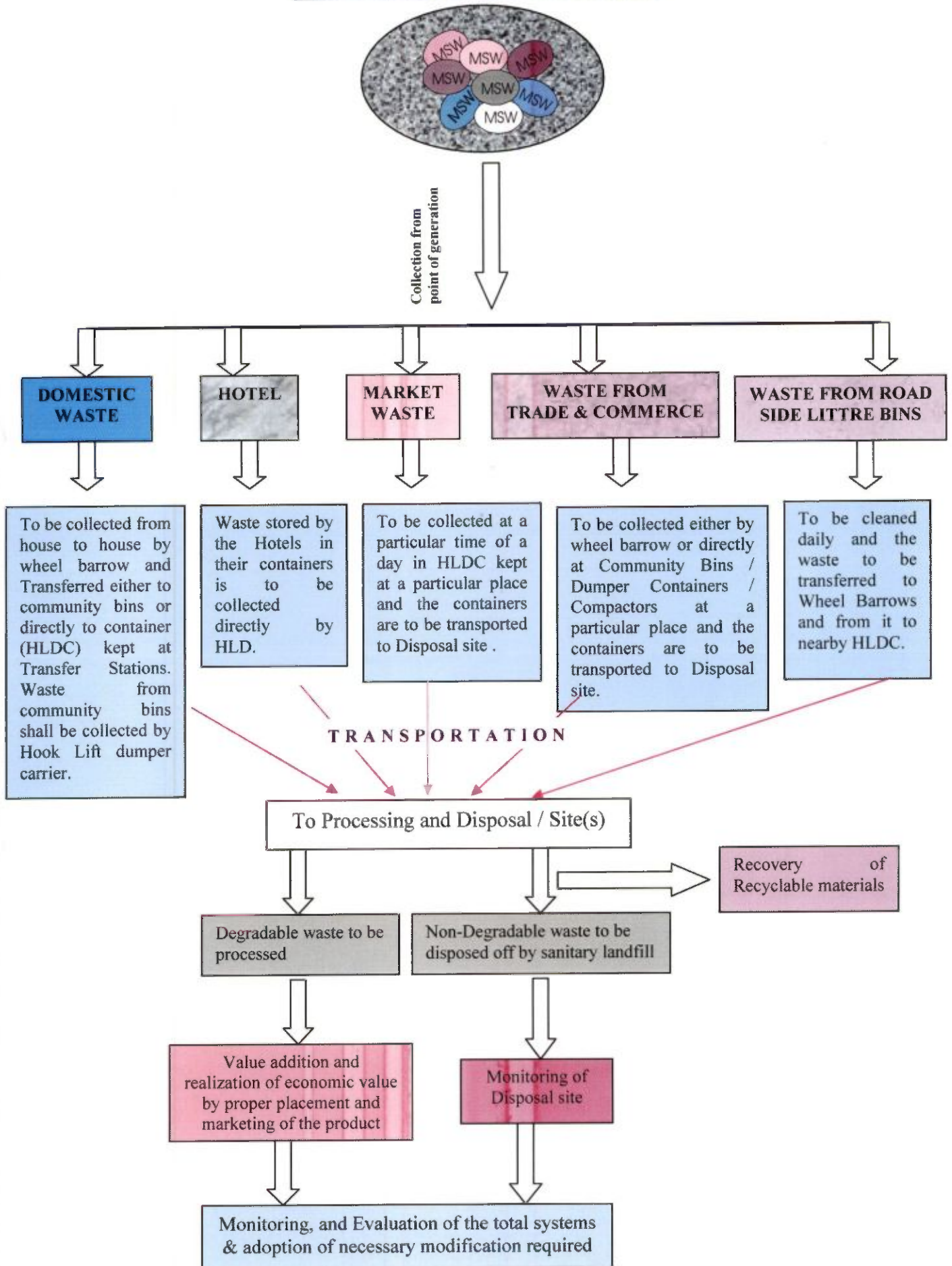

- iv) Collection through community bins from private societies multi storied buildings, markets, commercial and Office complexes etc.
- v) Door-step collection of waste from authorized / unauthorized slums or collection from the community bins to be provided in the slums by the local bodies.
- vi) Door-step collection of waste from posh residential areas on full-cost-recovery basis.

### **3.1.2 People's Participation in Collection:**

Success of the effective solid waste management particularly primary collection system largely depends on the proper co-ordination between people who are the generator and the staff who are the collector.

The average municipal solid waste characteristics depict high moisture content, with a relatively high density. Conventional metal bins and dumpers are found to be deteriorating within a short period due to the corrosive action of the waste mass. Hence, an appropriate design of the primary collection bins, with the help of modern technology is of prime necessity in order to reduce the recurring capital as well as maintenance costs.

## **3.2 MODUS OPERANDI**

### **3.2.1 Door-step collection through containerized handcarts with bells / whistles**

For domestic waste collection each collector may be given a tyre-mounted wheel barrow having eight detachable 20 litres containers and provided with a bell or whistle. Each collector shall be given a fixed area or beat for sweeping plus a fixed number or stretch of houses from which to collect the domestic waste. In congested or thickly populated areas, 300 running meters of road length and the adjoining houses may be given to each sweeper, whereas in less congested areas 500 running meters of the road length with adjoining houses may be allotted to a sweeper depending upon the density of population in the given area and local conditions. In low density areas even 500 running meters of road length can be given. Normally 50 to 75 houses coupled with the above road length may be taken as a yard stick for allotment of work to an individual sweeper.

### **3.2.2 Role of the Collector**

The collector should ring the bell or blow the whistle announcing his arrival at the place of his work and start sweeping the street. The people may be directed that on hearing the bell or whistle they should put their domestic biodegradable waste into the handcart of the sweeper.

No collector may be expected or directed to do house to house collection by asking waste from the doorsteps to save his time energy and productivity.

### **3.2.3 Collection of waste from Societies / Complexes**

In the private societies / complexes / multi stories buildings normally no collectors are provided by the local bodies and private collectors are generally engaged. It may be therefore be made compulsory for the management of the Societies / Complexes etc. to keep the bins in which waste has been stored at the easily approachable location to facilitate easy collection by the municipal staff. The local body shall

arrange to collect waste from these community bins through handcarts, tricycles or pick up vans etc. as may be convenient on day to day basis.

### **3.2.4 Collection of Wastes from Slums**

The local body shall collect waste from slums on bell system along their main access-lanes, with residents bringing their wastes to the handcart from their houses and / or from the community bins by using the pick-up vans or containerized handcarts or other means which may be convenient transferring the waste to the municipal waste storage sites for daily clearance. The local body may, if so desire engage a private contractor for daily collection of this waste. Performance certification by "Maholla / Baste Committee" may be insisted in such cases.

### **3.2.5 Collection from the door-steps in posh residential areas**

In the posh residential areas where the residents might not be willing for community participation and bring their waste to the municipal hand cart, door-step collection of wastes may be introduced for picking up domestic waste from households on day to day basis. Such service may be provided on full cost recovery basis and contractor may be engaged to provide such service if so desired to ensure that the waste generated from posh area is collected regularly and taken to the waste storage sites.

### **3.2.6 Collection of Duly Segregated Recyclable / Non-degradable Waste from Households**

NGOs may be activated to organize the rag-pickers in the city and the rag-pickers may be allotted lanes and bye lanes comprising of 150 to 250 houses for door-step collection of recyclables. The rag-pickers may be given identity cards by the NGOs for increasing their acceptability in the society. NGOs and / or the corporation may support the rag-pickers by giving them nylon bags for collection of recyclable waste from the door-steps.

### **3.2.7 Collection of Waste from the Shops and Establishments**

The shops and establishments normally open after 9 a.m. These timings do not synchronize with the work schedule of the sweepers. Under this situation one of these three alternatives may be adopted.

1. Sweepers may first carry out the work of street sweeping in the morning hours as usual and soon thereafter take up the work of door-step collection of wastes, after most of the shops open.
2. Rag pickers may be organized to collect the recyclable waste from the shops and establishments as soon as the shops get opened as most of such waste is recyclable. Working arrangement may be made with the shops and establishments accordingly. The shops & establishments may be asked to store waste in two bins if they produce waste other than recyclable waste also. The rag pickers may be organized to collect recyclable waste from such establishments on a daily basis. This arrangement may be made on 'No payment' basis on either side.

The recyclable material received by the rag-pickers directly from the shops and establishments would give them a better return. The waste would be dry and not soiled and would fetch a good



price in the market. This will work as an incentive for them to continue door to door collection. The associations of markets, shops and establishments may be persuaded to make an endeavor in organizing this service with the help of NGOs and rag-pickers in their market.

3. Door-stop collection service from the shops and establishments may be contracted out on 'full cost-recovery' basis.

### **3.2.8 Collection of Hotel and Restaurant Waste**

The hotels and restaurants may make their own arrangements of collection or be given door step collection service for their food wastes by the urban local body on full cost recovery and pro-rate basis. This door step service may be contracted out by the local body if so desired.

Charges for the collection of hotel waste may depend upon the quantity of waste to be picked up from the hotels and restaurants.

The cost recovery may be planned according to the classification of hotel / restaurant made on the above basis and decided in consultation with them.

A survey of the Waste Generation of the hotel / restaurants may be made before the collection rates are introduced and notified.

### **3.2.9 Meat And Fish Waste**

Meat and fish waste from the meat / fish markets should be removed on a daily basis departmentally or through contractor on full cost recovery basis.

### **3.2.10 Sweeping Of Streets & Public Spaces**

Sweeping of all the public roads, streets, lanes, by-lanes should be done daily if there is habitation or commercial activities on both the sides or on either side of the street. A list of such roads and streets together with their length and width should be prepared and a programme of their daily cleaning should be worked out by the local body keeping in views the norms of work (yardstick) prescribed. However, the roads and streets, where there is no habitation around and they do not require daily cleaning, may be put in a separate group and may be taken up for cleaning periodically depending upon the need of cleaning those roads or streets. Cleaning of such roads, streets etc. may be included in the list of periodical cleaning of such spaces to ensure that they do not become the dump yards and remain clean. A programme should be worked out for cleaning such roads, streets and open spaces according to the periodicity of cleaning decided upon and may be adhered to.

### **3.2.11 Transfer Of Waste**

Collectors shall transfer the waste collected from Door to door to a container kept at transfer station of their respective zones from where the container would be transported to dumping site by prime movers.

The waste collected in community bins / litter bins shall be directly transported to dumping site by prime movers.

Details of the transportation system and nature of vehicles have been given in Chapter 4 below.

### **3.3 Tools to be given to Sweepers**

With a view to ensure that the sweepers, more particularly female workers can work conveniently, appropriate types of tools and equipment should be given to them.

#### **3.3.1 Brooms**

The brooms should have a long handle to facilitate cleaning of the street without bending the body. In the cities where the broom allowance is being given or only broom sticks are provided to the sweepers, it should be ensured that long handle brooms are used or made by them for street sweeping. While making such brooms, a metal blade which can scrape the material sticking on the street should be fixed on the top of the broom or a separate metal scraper may be given to the sweepers to remove the sticking material from street while sweeping.

There is no yardstick about the number of brooms to be given to the sweepers per month. In some cities three brooms are given per month whereas in some cities only one broom is given per quarter of a year. One long handle broom per month considered being adequate for street sweeping. The bamboo (long handle) to which the broom is attached need not be given once a month as it has a long life. The same bamboo should be reused while making the broom. The bamboo may be replaced as and when required. It could be once in six months or once a year depending upon the local conditions of the city.

#### **3.3.2 Metal Tray and Metal Plate**

Each sweeper engaged in the street sweeping should be given a metal tray and a metal plate in for facilitating easy transfer of street sweeping from the streets into the handcart.

#### **3.3.3 Hand-Carts/Wheel Basrows**

Each sweeper engaged in street sweeping should be given a handcart having 8 containers of 20 liters capacity each. These containers should be detachable to facilitate the direct transfer of street sweeping from the container into the communal waste storage bins. Such containers should be lockable with a chain arrangement. The handcart should have sealed ball bearing and at least 3 wheels so that it can be used efficiently. Containerized tricycles can be used in lieu of the handcarts.

#### **3.3.4 Norms Of Work For Street Sweepers**

The sweepers may be assigned "Pin point" work according to the density of the area to be swept. The following yardstick can be adopted :

1. In high density area 300 RMT of road length covering about 200 to 175 houses
2. In medium density area 500 RMT of road length covering about 150 to 125 houses
3. In low density area 750 RMT of road length covering about 125 to 100 houses

The sweepers may be directed to sweep the roads and footpaths in the area allotted to them as well as to collect the domestic, trade and institutional wastes in their handcart from the households, shops and establishments situated on the road / street allotted them.

### **3.3.5 Cleaning of Surface Drains**

In some areas of Purulia Municipality there are open surface drains. In these drains quite often the sweepers and the people dispose of the waste un-authorized. These drains are required to be cleaned on regular basis to permit free flow of waste-water. Action should be taken to ensure that the sweepers and the citizens do not dispose of their waste into the drains.

Drain cleaning should be done regularly at least twice in a week and the cleaner should be given suitable handcarts and shovels for transferring the waste to the site identified for depositing such waste. The periodicity of cleaning such drains should be worked out looking to the conditions of clogging of drains.

### **3.3.6 Provision of Litter Bins**

For the facility of the citizens to dispose of their waste in hand such as used cans of soft drinks, used bus tickets, wrapper of chocolate or empty cigarette cases etc. litter bins should be provided in all the market places, office complex areas, places of public gathering and on the important roads at reasonable distance ranging from 25 meters to 250 meters depending on the density of the road or market place. The removal of waste from these litter bins should be done by the sweepers during their street cleaning operations. The waste from the litter bin should be directly transferred into the handcart of the sweeper.

Such facility may be created at no cost to the local body by involving the private sector and giving them advertisement rights on the bins for a specified period or by allowing them to put their name on the bins as sponsor. Litter bins should be put in posh as well as poor areas and the sponsor should put such bins in both the areas in the proportion decided by the local body.

### **3.3.7 Temporary Waste Storage Depot for Bulk Community Waste**

The Bulk community waste storage has to be properly linked with Collection System adopted by the city / town where house to house collection.

The local body may depend upon the system of Collection adopted in the town, identify the locations where community waste storage facilities shall be created.

### **3.3.8 Segregation Of Recyclable / Non-Degradable Waste**

The local body shall make serious endeavor to motivate households, shops and establishments to segregate recyclable / non-degradable wastes at the source of waste generation and hand over such waste to the rag-pickers. The arrangement may be made on 'no payment on either side basis' for collecting the recyclable / non-degradable wastes by the rag-pickers and simultaneously mobilize NGOs to take up the work of organizing rag-pickers and motivating them to collect recyclable wastes from the doorstep instead of picking up solid waste from the streets, bins or disposal sites. This step may create some earnings to some BPL persons.



The Local Bodies may actively associate resident associations, trade & street associations & NGOs in the awareness campaign to motivate people for segregation of such waste at source.

Priority must be given for the source segregation of recyclable wastes by shops and establishments. Efforts may be made to introduce segregation of recyclable waste at source and its collection from the doorstep by the rag-pickers. In case of households such an arrangement may be made within one year.

The rag-pickers may be given an identity card by the NGOs organizing them so that they may have acceptability in the society. The Local body may notify such an arrangement made by the NGOs and advise the people to cooperate.

As soon as this arrangement is made and a reasonable awareness campaign is carried out it shall be made compulsory to do source-segregation from the date that may be notified by the local body.

#### **4.0 TRANSPORTATION OF WASTE**

Transportation of waste is very important aspect so far cost is concerned. Proper planning and management of man machine and vehicle is of utmost important to minimize the cost.

a) The waste collected from door-to-door shall be transferred to transportation containers viz. **Hook Lift Dumper Containers 5 to 7.5 cu.m. capacity (HLDC), Hydraulic Dumper Container (HDC)**, etc. kept at transfer station located at various zones.

b) The transportation of waste from the bulk community waste storage sites or transfer stations may be planned in accordance with the frequency of containers becoming full. The locations where the containers are placed may be grouped into four categories is given below. These containers should be of about 1000 ltr. capacity still bins with **Swivel Castor Wheel Automatic Lifting** arrangement and are to be transported directly to dumping site by prime movers .

- a) The containers which are required to be cleared more than once a day.
- b) The containers which are required to be cleared once a day.
- c) The containers to be cleared on alternate days or twice a week.
- d) The containers which take longer time to fill to be cleared once a week.

The various types of transportation vehicles which may be used for transportation of waste from Purulia Municipal area to dumping site are **Hook Lift Dumper Carrier (Hydraulic), Hydraulic Dumper Carrier, Tractor-Trailer, Ordinary Truck**.

#### **4.1 Transportation Of Waste From Hotels & Restaurants**

The hotels and restaurants waste shall be collected on day to day basis either departmentally or through a contract. Door-step collection system may be introduced for the collection of this waste. Eight refuse collectors with back loading facility or motor vehicle with close body may be used. This entire collection and transport system could be privatized and rates may be prescribed by the local body. 33% spare vehicles may be kept to ensure reliable service.

#### **4.2 Transportation of Construction Waste**

Removal of construction waste is the liability of waste producer. If he does not remove the construction waste, it may be removed by the local body on full cost recovery basis. One of the following methods may be adopted for transportation construction waste:

- i) Here skip renting system may be introduced; the skips shall be transported by hydraulic system at the time mutually agreed between the parties i.e. local body and waste producer.
- ii) The local bodies may also use front-end loaders and trucks, hydraulic dumper truck for transportation construction waste.

#### **4.3 Transportation of Waste from Narrow Lanes**

Quite often small quantity of waste is disposed of in the narrow lanes which cannot be removed by sending out usual transport vehicle. Wheel barrows may be used for removal of such waste.

Small vehicles may be used for the collection of waste from narrow lanes and transfer the same to containers kept at nearby transfer station for transportation of waste to dumping site. The transfer stations itself should be transported to the dumping ground by the Prime Movers. Facility of ramp may be provided for transferring the waste from the collecting vehicles to the transportation vehicles. The requirements of such large container are worked out on the basis of total quantity of waste expected to be brought to the transfer station.

#### **4.4 Type of Vehicles to be Used**

The vehicle which synchronizes well with the community waste storage system shall be utilized to prevent multiple handling of waste which may be done as under.

- i) Wheel Barrows with 8 containers of 20 lts. Capacity; 4 for Bio-degradable and 4 for non- degradable for house to house collection for solid waste.
- ii) The box type or wheel borrows are suggested to be replaced preferably with containers / bins in narrow lanes.
- iii) The filled up containers are proposed to be hauled away by prime movers and in doing so the filled up skips / containers / trailers being replaced by empty one. The transfer

station needs to be designed in a proper manner by constructing suitable ramps and vehicles bays for transferring waste from the primary collection fleet to transportation vehicles / containers.

- iv) The container lifting devices such as Dumper placers / skip lifters/ Hook Lift Dumper Carrier may be utilized for transportation of large size containers to the transfer station of the disposal site.

#### **4.5 Routing of vehicle**

Routing and scheduling of vehicles are of prime important for management of waste transportation system. Depending on the containers to be cleared each day, the route for lifting the container may be worked out avoiding zigzag movement of the vehicle to the extent possible.

#### **4.6 Workshop Facility for Repairing and Maintenance of the Vehicles**

Purulia Municipality must have adequate workshop facility for the regular maintenance to the various types of accessories and fleet of vehicles. Such facility may be created by the local body departmentally or through a contractual arrangement. The workshop should have adequate technical staff and spares to ensure that at least 80% of the vehicles remain on the road each day and the down time of repair / maintenance is minimized to the extent possible. Spare assemblies should be kept available which could give as replacement till such time necessary repairs are carried out. The workshop should be preferably headed by an automobile or mechanical expert.

Team incentives should be introduced in workshop for ensuring more than 80% of vehicles on the road throughout the month.

The workshop should be run in more than one shift. Technical staff as per the requirement may be kept in the second or third shifts to ensure that more than 80% of vehicles remain on the road for optimum utilization of the fleet of vehicles of the local body.



## **5.0 DISPOSAL OF WASTE**

The disposal of waste, processing of degradable waste and disposal of non-degradable waste, is one of the most important aspects of integrated waste management as unscientific disposal of waste can cause irreparable damage to the environment and subsoil strata and human health and life. No local body should therefore allow any dumping of waste at unauthorized sites. Suitable landfill sites must therefore be urgently identified and designated as Landfill Sites for the disposal of rejects from the Compost Plant and for non-biodegradable waste. Municipality should arrange required land for disposal of waste keeping in view the requirements of the city for at least the next 15 – 20 years. Depending upon the quantity of waste to be disposed of annually, the requirement of land has been worked out below and the land may be acquired accordingly.

Composting is the process of waste disposal which our predominantly agricultural country must follow. It can be done by aerobic and anaerobic processes. The aerobic process is a biological oxidation process where the organic portion of the waste is decomposed and a material useful to agriculture having N: P: K values is produced. This process can be completed in 45 to 50 days.

An aerobic process of composting is very slow. It takes about 180 days to make compost. It is therefore not desirable to go for anaerobic composting. Besides it does not kill pathogens.

The aerobic composting is suitable under Indian conditions. Indian waste generally contains 30% to 50% of organic wastes. It also has the required moisture content, C/N ration etc. It is a low cost option and does not require high skills. It has a market potential and land requirement for disposal of waste gets reduced.

Disposal of SW involves processing of bio-degradable portion of the waste into manure and generation of bio gas and disposal of the remaining after recovery of recycleable materials of the total solid waste.

### **DISPOSAL TECHNOLOGIES**

Municipal garbage is to be disposed of by the combination of i) processing of waste and generation of **bio-gas** and ii) disposal (**Sanitary Land Filling**). The bio-degradable waste from households and daily market waste are proposed to be composted and other types of wastes will be disposed off by Sanitary Landfill. The refuse from hospitals and nursing homes with high pathogenic contents are proposed to be disposing off as per the regulation related to disposal of Bio-medical waste. The market wastes having high organic contents are very efficient for composting. In view of the fact that municipal garbage carries high quantity of cinder, ash, silt, earth and other inorganic materials and as such it does not have any fuel value. So the possibility of generation of power from solid waste appears to be difficult unless separation of organic and inorganic constituent of waste is made directly at source.

Most preferred disposal option suitable for small and medium size municipal town is the combination of processing of waste by Composting and disposal of the remaining by Sanitary Landfill method.

### 5.1 Generation of BIO-GAS

According to the Purulia Municipality estimation, approximately 70 MT of waste is generated daily basis in the Purulia Town. It was seen that for the Purulia Municipality the amount of the Biodegradable Waste generated (43 MT) was considerably higher in comparison to the Non Biodegradable waste. Thus, a Bio gas Plant layout is ideal for the Project Area and will be designed for the Purulia Municipality. Primarily, eight 5 MT Bio gas Plants are proposed for Purulia Municipal Area.

At a glance, the benefits which can be drawn out of Solid Waste Management are as follows:

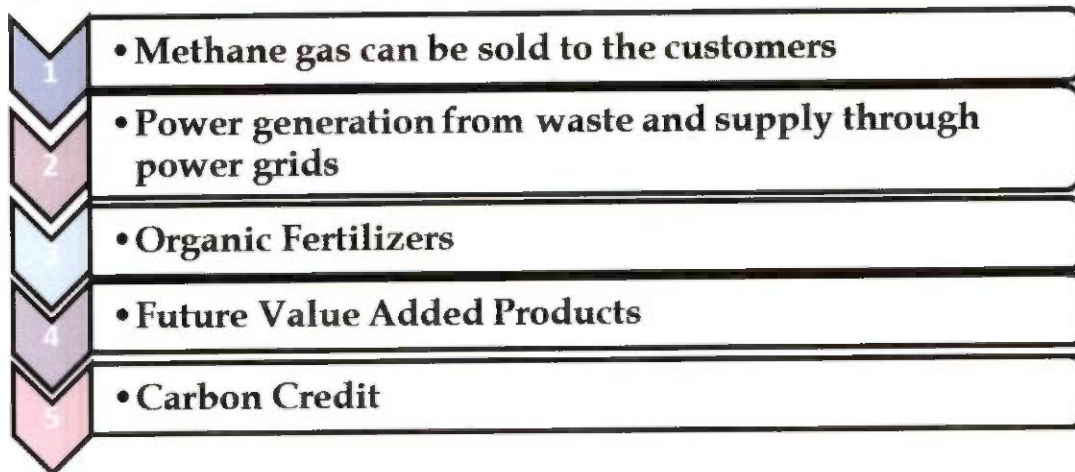

Benefits of Solid Waste Management

### Waste Generation Trend

Purulia is a municipality well known for its tourism and horticultural importance in West Bengal. Following are the major sources for generation of Solid Waste:

Domestic;

Commercial Areas and Vegetable Markets;

Household and other factories;

Hotels and Restaurants;

Health Care Facilities

Slaughter House;

Street Sweeping and Construction Activities

Horticultural Waste

The following diagram shows the proposed approach for a comprehensive solid waste management system. The overall solution should be a combination of the following:

Sorting and segregation

Recovery of Recyclables

Recovery of inerts

Conversion of biodegradables to valuable products like biogas and fertilizers

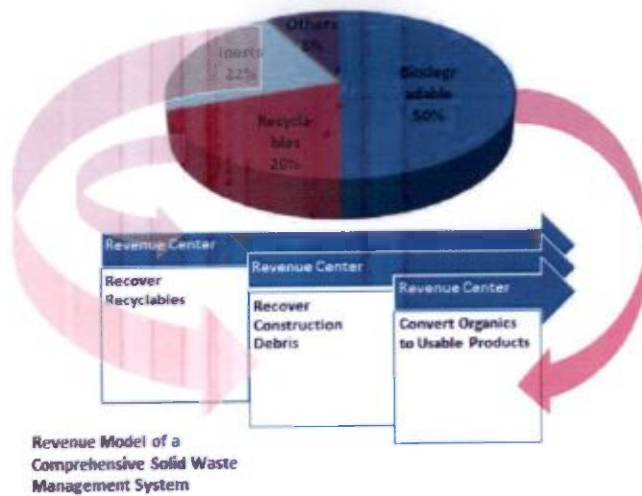

### Solid Waste Sorting Operation

The collected solid waste will be segregated into biodegradable and non biodegradable components. The non-biodegradable components will be sorted into paper, plastic, glass, metals and inerts. There is a ready market for all of these sorted materials in nearby urban centers for these recyclable markets. It is recommended that Purulia assigns one of the companies operating in the region for sorting the waste so that the biodegradable component can be fed into the biogas generating facility.



### Solid Waste Handling Technique

Approximately 70 MT of solid waste is generated on a daily basis. Thus the expected Biodegradable Waste to be generated daily is approximately 43 MT. It is recommended that biogas plant should be setup for optimal utilization of the processed waste.



## Science of the Process



Waste Processing Flow Diagram

The principle as explained in the figure above produces organic manure (soil conditioner) and biogas based on the process of Bio-Methanation. The organically rich biodegradable portion of solid waste is mixed with recycled water to form slurry. The slurry is then aerobically digested in Pre-digester, where organic matter is converted to organic acids. Prior to Pre-digestion, final digestion is required. The Pre-digestion is accentuated by addition of hot water and intermittent aeration. Pre-digestion reactions are exothermic and temperature rises to 40 °C by itself. Hot water obtained using solar heater is added to raise the temperature to 50 °C.. Their main role is to digest proteins and low molecular weight carbohydrates to produce volatile fatty acids.

The smaller molecules like proteins and simple carbohydrates are degraded during Pre-Digestion. The pH of the feed slurry to Pre-digester is around 7-8. The retention time (Hydraulic time) of 4 days is maintained in the Pre-digester. After the Pre-digestion the pH reduces to 4-5 pH units. The predigested slurry is further digested under anaerobic conditions for about 15 days. The process of methanogenesis takes place in this digester. Methane and carbon dioxide are the terminal products of this process. Methane is produced from two primary substrates viz. Acetate and Hydrogen/ Carbon dioxide (Formate). At this stage the organic acids are converted by consortium of methane bacteria to methane and carbon dioxide. The undigested lignocelluloses and hemi celluloses then flow out as high quality organic manure slurry. The pH of this slurry ranges from 7.5-8. Since the waste is processed at higher temperature, weed seeds are killed completely and the manure becomes weed free.

The three steps of Biogas production are as follows; 1) Hydrolysis 2) Acidification and 3) Methanogenesis. Various bacteria are involved in these processes.

### Hydrolysis

In the first step (hydrolysis), the organic matter is analyzed externally by extra cellular enzymes (cellulose, amylase, protease and lipase) of microorganisms in the pre-digester tank. Converting solid waste into liquid form in the mixer stimulates this step. Bacteria start decomposing the long chains of the complex

carbohydrates, proteins and lipids into shorter parts. Proteins are split into peptides and amino acids. Simple carbohydrates and proteins are degraded completely.

### **Acidification**

Acid-producing bacteria involved in the second step convert the intermediates of fermenting bacteria into acetic acid ( $\text{CH}_3\text{COOH}$ ), hydrogen ( $\text{H}_2$ ) and carbon dioxide ( $\text{CO}_2$ ) in the Pre-digester. These bacteria of the genus bacillus, are aerobic and facultative anaerobic, and can grow under acidic conditions. The aerobic conditions in the pre-digester will be maintained by an air compressor. The bacteria use the oxygen dissolved in the solution producing acetic acid, thereby reducing the compounds with a low molecular weight into alcohols, organic acids, amino acids, carbon dioxide, hydrogen sulphide and traces of methane. The pH of the raw slurry falls from 7.5 to about 4.5 to 5.5 in the pre-digester. , Various zones are formed in the pre-digester and different bacteria dominate these zones. Addition of hot water helps in eliminating the mesophilic bacteria and selection of thermophilic bacteria. But these thermophilic bacteria can operate at lower temperatures also. Hence hot water added even once a day should be sufficient for maintaining the pure consortium in the pre-digester. However if it is possible to maintain the temperature of pre-digester in the range of 50-55°C throughout the day, the performance of pre-digester will be enhanced and the holding time may be further reduced, by maintaining temperature in the range of 50-55°C, throughout the day.. The hot water helps in hygienization of the slurry by killing the enteric bacteria that may be present in the waste. Some Gram negative Enterobacteria and Coliform bacteria have been isolated in the raw slurry. However in the second zone these bacteria are totally eliminated. From the pre-digester tank, the slurry enters the main tank where it undergoes anaerobic degradation by a consortium of archaeobactereacea belonging to Methanococcus group.

### **Methane Formation**

Methane-producing bacteria, in the third step, decompose compounds with a low molecular weight. . In contrast to acidogenic and acetogenic bacteria, methanogenic bacteria belong to the archaeobacteria group, a group of bacteria with a very heterogeneous morphology and a number of common biochemical and molecular-biological properties that distinguish them from all other bacterial genera. It is advisable to circulate the generated biogas back into the system using a small compressor. This would enhance the reduction of Carbon dioxide to methane and enrichment of methane fraction in the biogas. The separation of two stages in methane production helps in improving the purity of methane gas, thereby increasing its fuel efficiency. However, the average composition round the year would depend on how effectively pre-digester temperatures can be maintained. It is taken through a GI pipeline to utility points. Drains for condensed water vapor are provided online. The biogas burns with a blue flame and is ideal for cooking. Alternately, it can be used to produce electricity in a dual fuel biogas-diesel engine.



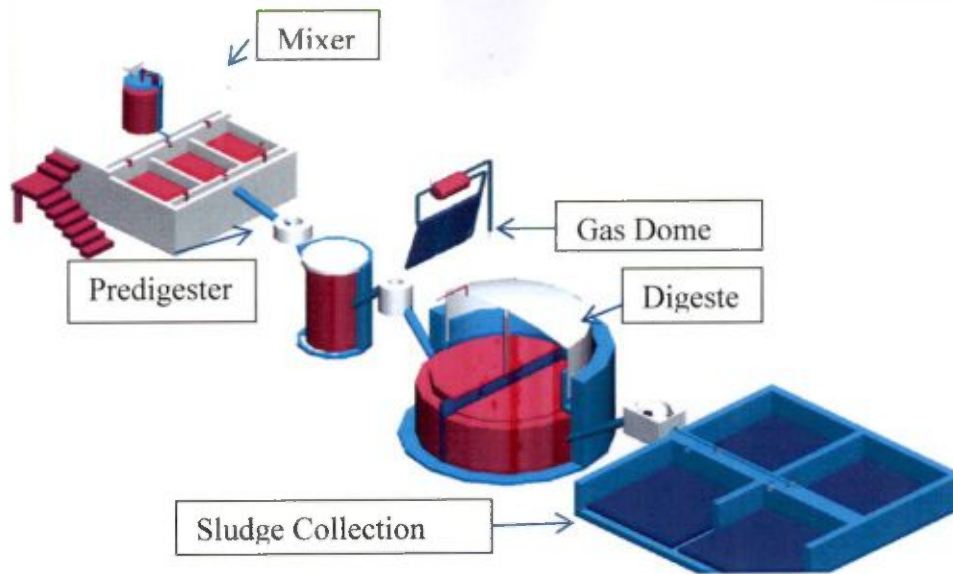

### Process Schematic of the Waste to Biogas-Organic Fertilizer System

#### **5.2 SANITARY LANDFILLING**

This is presently the commonest method of waste disposal. But it has associated problems of land and sub soil water contamination besides availability of land is becoming scares from year to year for filing of waste. Efforts have therefore to be made to minimize the wastes going to the landfill by resorting to composing of organic waste and only rejects should be land filled from the dates that may be notified by the local bodies after setting up of the Compost Plant.

This method will have to be followed for the greater mass of waste with a proper sanitation approach, in place of the present process of indiscriminate dumping. Adequate precaution against leachate pollution, fly, insect, odor and other unsightly problems, will have to be ensured for proper environmental protection. The fuel gas generated at landfill site can be salvaged and put into proper use for energy recycling. Assistance from developed countries to achieve this object will be of high necessity. A conceptual arrangement for sanitary landfill system has been given below.

##### **5.2.1 Identification of Suitable Lands for Disposal of Waste Site selection :**

Local bodies must identify suitable landfill sites 1) for the disposal of rejects from the compost plants and 2) for making a secured landfill for the disposal of non-biodegradable items following the directions of central or state pollution control boards. Such sites should be large enough to meet their requirement of waste disposal for 15 to 20 years and capital investments could be made for making the site fit for disposal of wastes.

- a) The landfill site should be at least 0.5 km. away from the habitation so that it does not cause nuisance to the people on account of emission of foul smell etc.
- b) It should have relatively impervious soil strata.
- c) It should have good approach roads.
- d) It should large in size.
- e) Landfill site should be very near to compost area to minimize transport cost.



- f) Landfill site should not be very near to water bodies like lake, canal, river etc.

### **5.2.2 Development of Site**

- a) If the soil has some porosity, it should be made impervious before being used for land filling, by liners of compacted clay, plastic or concrete.
- b) Approach roads may be made to connect the landfill site to the main road.
- c) Internal approach roads are made to facilitate easy movements of vehicles and tipping of wastes at the landfill site during the monsoon months.
- d) The local bodies should set up monitoring stations near the major landfill sites to ensure that quality of subsoil water does not get affected on account of leachate emerging from the landfills. A leachate pit is required at the lowest point for pumping leachate.
- e) A small store room may be constructed at the landfill site to store the tools and equipment required.
- f) A compound wall or fencing by barbed wire may be done to prevent blowing of waste due to air, controlling the entry of unauthorized persons and conceal the unsightly appearance of the of the landfills. The site should be surrounded by adequate no. of trees.
- g) In large cities having population above 5 lakh a mechanical or computerized weighbridge may be installed for monitoring the quantities of wastes being carried by the vehicles to the landfill.
- h) Trees may be grown around to create a green belt to improve the environmental conditions and screen the site from the people's view.

### **5.2.3 Landfill Operation**

- i) Compost-yard rejects and non-degradable may be brought to the landfill site for disposal.
- j) Bulldozers may be used on a daily basis for spreading and compacting of such waste and covering it with inert material.
- k) The waste may be covered with 7 to 10 cm. thick layer of inert materials such as construction wastes to avoid any foul smell and breeding of rodents and insects.
- l) The landfills may be carefully monitored against subsoil contamination through leachate.
- m) Gardens or playgrounds may be developed on the landfill and they may be made useful to the society or put to a profitable use.
- n) On-site construction is not recommended for ten years after closure of the site (or 25 years in temperate regions).
- o) Waste should not be allowed to be burnt at the landfill to avoid air-pollution.
- p) Toilets should be constructed to prevent open defecation and make arrangements for extinguishing accidental fires.
- q) Records may be maintained of the wastes received at the landfill and the number of trips made by each transport vehicle on day to day basis.

Municipality	Tare Weight (KG)	Full Weight (KG)	Waste Total	Plastic	Metal	Glass	Paper	Biodegradable	Biodegradable %
Purulia	2950	5670	2720	690				2030	75%

The following conclusions can be drawn from the sampling exercise:

Nearly all the glass, paper and metals are sorted out of the solid waste even before it can reach the solid waste facility. It is a good practice as the recyclables are definitely getting recycled.

The pre-sorting would reduce the revenue that the solid waste facility could have earned by selling the recyclables to the scrap market.

The remaining plastic was mostly of low grade thin sheet. The only applicable process for conversion this plastic is to breakdown the plastic into dirty fuel through Pyrolysis so that it can be subsequently sold as furnace oil to factories.

The final solution will not require any process for recycling glass, metal and paper as these components can be expected to be drawn back into the economy.

The main revenue sources from the process will be from

- Gas and or electricity generated from the biogas
- Organic fertilizer
- Fuel oil from the plastic pyrolysis
- Selling any other recyclables recovered will be sold in the market through solid waste

Biodegradable materials will account for 85-90% of the waste finally reaching the solid waste facility. It is projected that as the waste reaching the solid waste site is after the sorting done by rag pickers and the residents, the biodegradable part as a percentage of the whole waste generated is expected to be close.

Therefore, the plant should be designed on the basis of the overall waste tonnage expectation while using the solid waste quality observed during the sampling process.

## BASIC CONSIDERATIONS

1. Domestic Waste shall be segregated (bio-degradable and non-degradable) at generating points House to House in separate containers.
2. Each family would preserve the degradable waste in green container & non-degradable waste in yellow container.
4. House to House collection shall be done by Wheel Barrows having eight containers; four for bio-degradable and another four non-degradable waste.
5. There will be number of Transfer Stations in each zone . **(For Zones please see Table No. 2 & 7)**
6. At Transfer Stations waste from Wheel Barrow shall be transferred to Community Bins / Dumper / Refuse Trailer from a ramp.
7. Market Waste should be collected through Community Bin(s) to be placed at suitable points.
8. Trade Waste should be collected by Wheel Barrows or through Community Bin(s) to be placed at suitable points
9. Waste from Market shall have to be dumped in Transfer Stations. Each Market\Commercial Centre should have one Transfer Station in the form of containers. No road side open vat should be allowed. All road side bins must have cover and with necessary arrangement for tilting directly on to the transportation vehicles.
10. From Transfer Stations waste shall be transported to disposal site by prime movers.
11. Penalty may be imposed for haphazard throwing of waste.
12. Variety of non-degradable waste can be recycled after processing.
13. NGOs may be encouraged for employing daily wage earners to collect the non-degradable waste and to sale them.
14. One Wheel Barrow will cover about 50 to 75 holdings in a day and will make three trips to Transfer Stations.



15. Each and every hotels should keep two containers one yellow another green for storing their non-degradable & degradable waste respectively which shall be collected by the transportation vehicles at the particular time on each day.
16. Capacity of Refuse Trailer is 1.0 - 1.5 MT.
17. Capacity of Dumper / Truck is 5 - 7.5 MT
18. In an average one Tractor will be able to make 4 - 5 trips per day.
19. Moisture content in organic waste is about 60%.
20. Domestic SW contains about 60% organic matter and remaining 40% is inert materials.
21. Hotels generate SW @ 750 gm/bed and contains about 50% organic matter and remaining 50% is inert materials.
22. Market SW contains about 80% bio-degradable matter and remaining 30% is inert materials.
23. Assumed that Trade Waste contains about 10% bio-degradable matter and remaining 90% is inert materials.
24. Assumed that Agricultural Waste contains about 100% bio-degradable matter neglecting the very few mixed inert materials.
25. Assumed that Clinical Waste generated @ 1500 gm per bed/day.
26. In Clinical Waste infectious material is 25%.

## **6.2 PROCESSING AND DISPOSAL OF WASTE**

The solid waste of Purulia Municipality is proposed to be disposed of partly by processing and partly by sanitary landfill method. Bio-degradable part will be processed bio gas will be generated.

Present land availability to Purulia Municipality for disposal of SW is about 16 acres located at a distance of 2 Km from the central place of the town. The detailed design of the disposal system is given below.

### **6.3.1 Design Of Solid Waste Processing System**

The Solid Waste Management Facility in Purulia Municipal Area is shown in figure below. It is proposed to be a Biogas Plant, which will produce electricity in the long run.

## Proposed Solid Waste Management site

### The Bio-Gas Plant at Purulia Municipal Area

Total capacity to be provided at the site is 40 MT per day. This will be done by a combination of eight 5 ton plants. This would provide a sufficient redundancy and flexibility to the operation with changing load with different seasons. The Bio-Gas Plant Facility at Purulia will require an area availability of approximately 3200 sq.m, to handle a capacity of 40 MT of Biodegradable wastes, on daily basis as shown in figure below. Any additional available land can be used as a sorting facility.

### Overall Arrangement of Eight 5 MT Biogas Plants

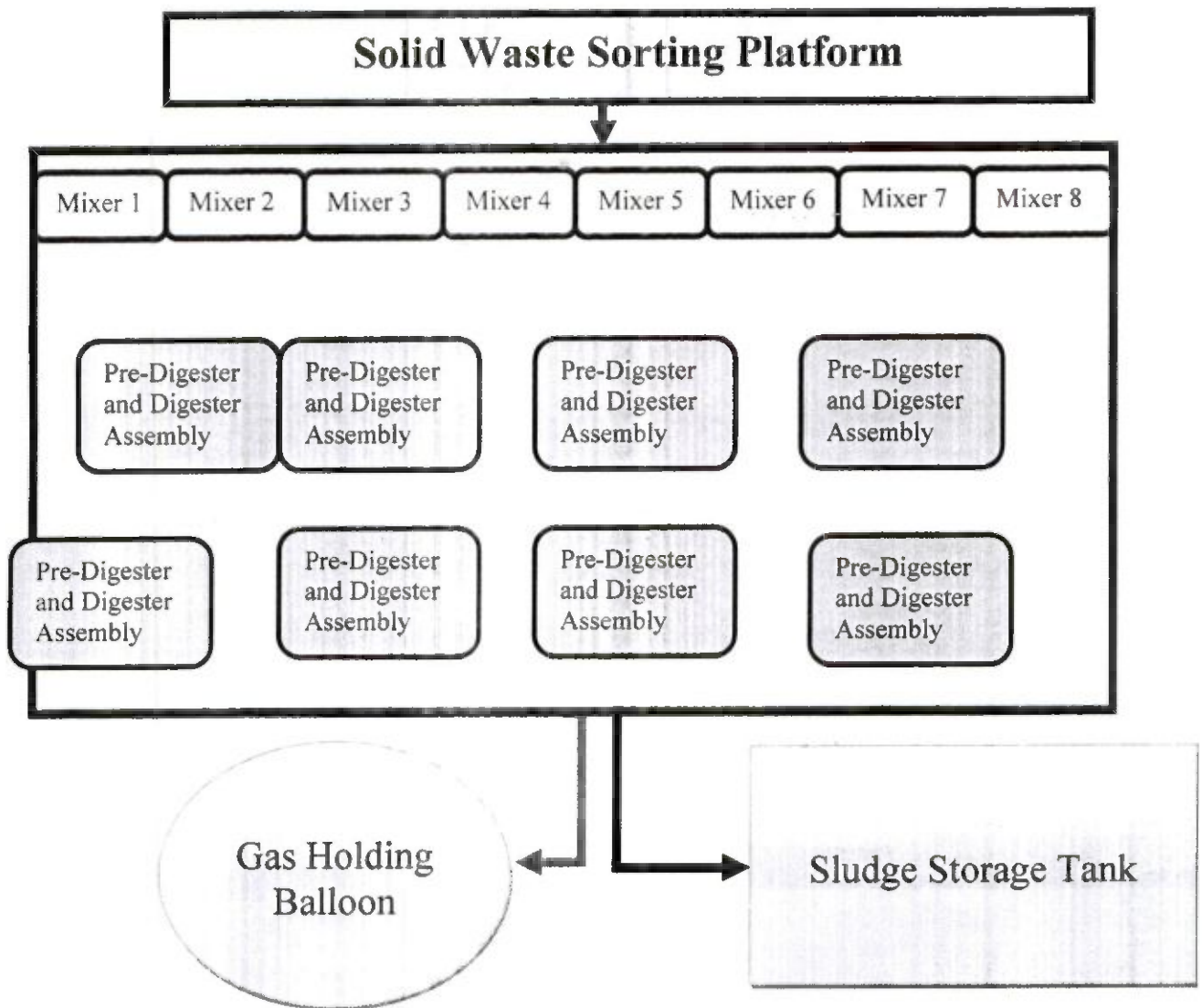

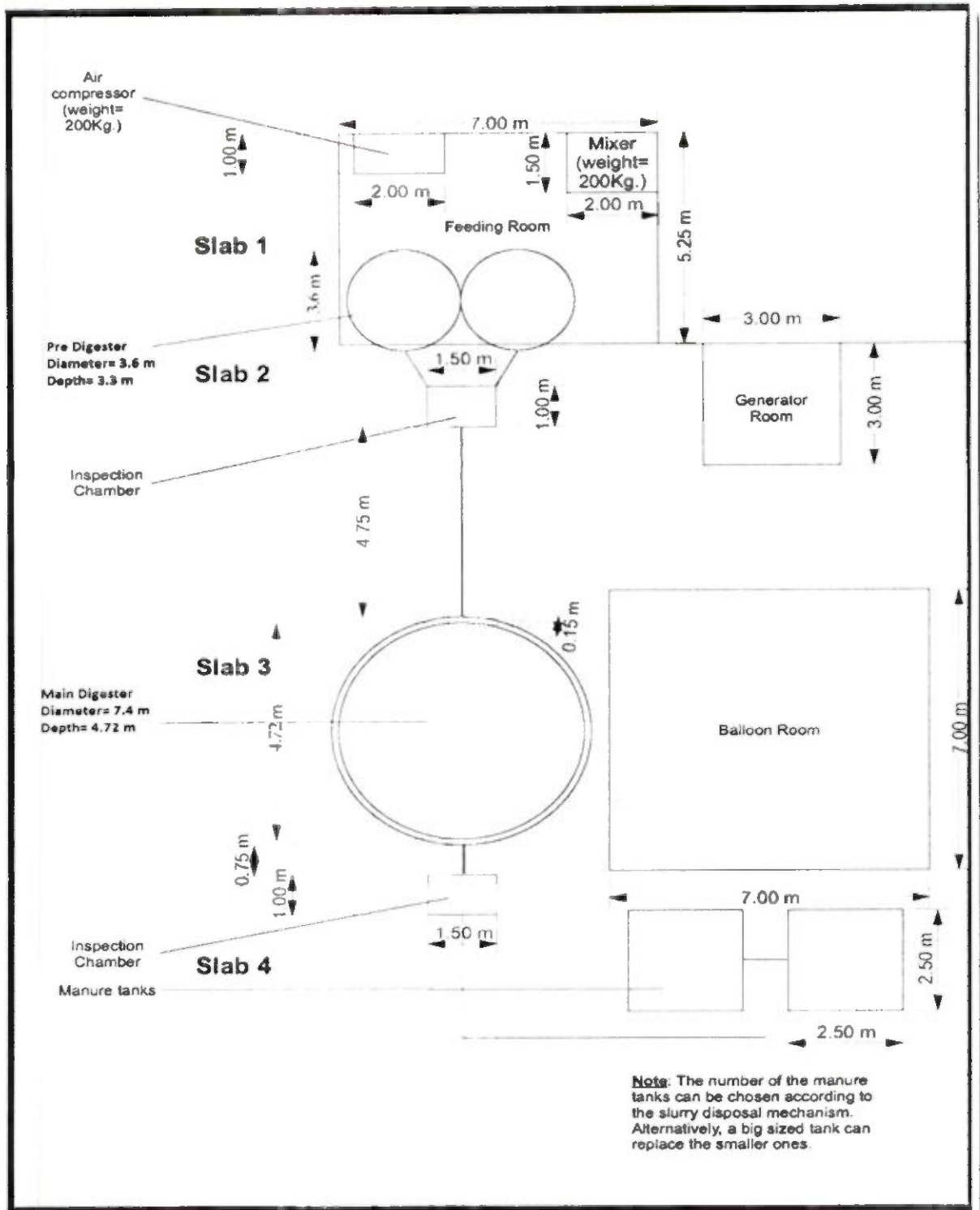

**Proposed Biogas Plant Layout (each 5 MT Plant) for Purulia Solid Waste Management**



## Components of Biogas Plant

Following are the major components will be installed at each of the SWM Facilities (Biogas Plants) in Purulia, Purulia District as shown in the figures below.

- **A Mixer for crushing the solid waste**

Here the organically rich bio-degradable portion of solid waste is mixed with recycled (depending on availability) and/or fresh water to form a uniform slurry. The water ratio needed for this technology is 1:1 i.e., for 100 kg of waste, 100L of water will be needed. All of the required water need not necessarily be fresh water; Recycled water from the plant and from Sewage treatment plants can also be used. It is important to maintain the ratio, as addition of excess amount of water can lead to washing away of culture, thereby ceasing the process. The microbial quality of water needs to be checked regularly.

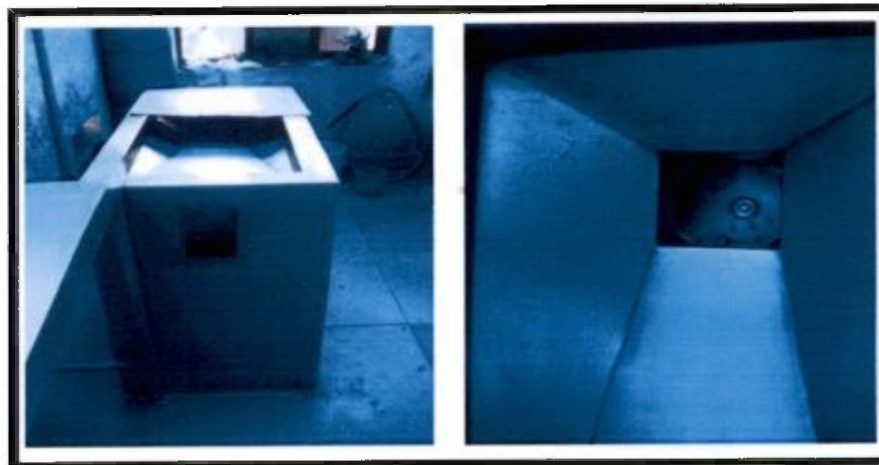

A Typical Mixer for crushing Biodegradable Waste

- **Thermophilic Aerobic Pre-Digester Tank**

Each 5 MT Bio-Gas Plant will have two Aerobic Pre-Digesters. Each Pre-Digester will be 2500 mm in diameter and 4000 mm deep. The Pre-Digesters will be aerobic in nature as name suggested. The Pre-Digester will receive flow of oxygen through air supplied by compressor housed in the Mixing and Feeding Room. The slurry will be aerobically digested in the pre-digester, where organic matter is converted to organic acids. The pre-digestion is accelerated by addition of hot water and intermittent aeration. Predigestion reactions are exothermic and the temperature rises up to 40oC by itself. The main role of the bacteria is to digest proteins and low molecular weight carbohydrates to produce volatile fatty acids. The retention time in the pre-digester is 4 days. Before introducing the slurry in the Main Digesters, it will pass

through 1500 mm x 2500 mm inspection chambers. The aeration grid in the chamber will be as shown in figure below.



A Typical Pre-Digester

- **Air Compressor**

The air compressor will be placed in the Mixing and Feeding Room. The pre-digester requires aerobic condition. To maintain aerobic conditions in the pre-digester aeration is given at regular intervals using a compressor. Aeration not only supplies oxygen but also enhances the uniformity in the slurry and in-turn promotes proper digestion for further fermentation in the main digester.

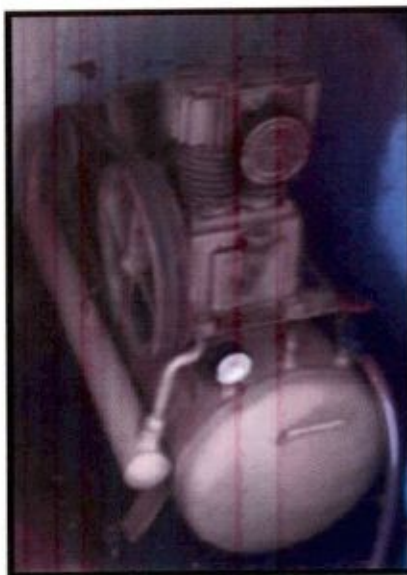

Typical Air Compressor

- **Solar Unit for Hot Water**

The Solar Power will be used for heating water which will be used for raising temperature in Aerobic Pre-Digester. Low temperatures arrest microbial growth and halt the process of bio-methanation.

- **Main Digester tank**

This is the heart of the Biogas Plant. There will be a main digester for each 5 MT Plant. The digester will be anaerobic in nature. The Main Digester will be 5400 mm in diameter and 6000 mm deep with floating roof. The predigested slurry will be further digested under anaerobic conditions for about 15 days. The process of methanogenesis takes place in this digester. Methane and carbon dioxide are the terminal products of this process. At this stage the organic acids are converted by consortium of methanogenic bacteria to methane and carbon dioxide which get collected in the dome above the main digester. The excess gas will be stored in a gas balloon as shown in the figure below. The undigested slurry will be transported to Manure Pits as explained below.

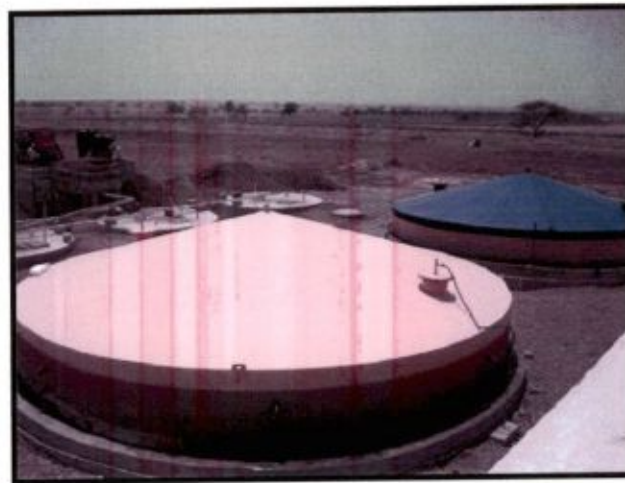

Typical Anaerobic Digester

- **Gas Holder/Gas Balloons**

Balloons are required to store the gas produced, when the production is higher than the utilization, as this results in the gas escaping from the water seal.



A Typical Gas Balloon



- **Manure pits**

The undigested lignocelluloses and hemicelluloses that flow out of Main Digesters as high quality organic manure slurry. The pH of this slurry ranges from 7.5-8. Since the waste is processed at higher temperature, any weed seeds are killed completely and the manure becomes weed free. Depending upon the raw materials used and the conditions of digestion, this sludge contains many elements essential to plant life – Nitrogen, Phosphorous, Potassium plus small amount of salts (trace elements), indispensable for plant growth such as boron, calcium, copper, iron, magnesium, sulphur, zinc, etc. It is a good source of all the essential elements needed for restoring the fertility of the soil. The Manure Pits will be located on end of the 5 MT Biogas Plant as shown below.

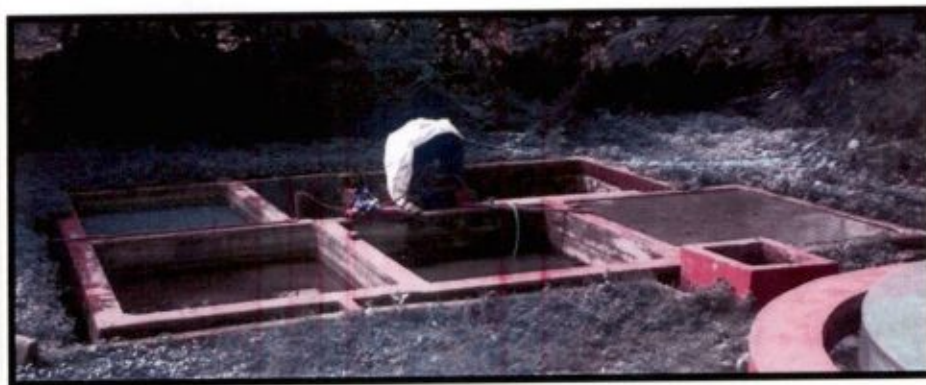

A Typical Manure Pit

- **Effluent water collection and recirculation system**

The sludge flows out into the manure pits, the water separated here is recycled to the mixer for feeding. Hence brick/concrete tanks are used to store this water.

### 6.3.2 Technical Specifications of Bio-Gas Plant

#### **Specifications of the Tanks & Pits**

**Table 3:**

**Specifications of the Tanks & Pits**

S.No	Description	Nos	Dimensions	Volume of Each Tanks/Pits/ (cu.m.)	Total Volume of Tanks/Pits (cu.m.)
A	Primary Digester	2	3.6 m Dia x 3.3 m Deep	33.57	67.14
B	Main Digester	1	7.4 m Dia x 4.72 m Deep	202.90	202.90
C	Manure Pits	4 Cells	4.0 x 4.0 x 4.35	72	288
D	Outlet Chambers	2 Cells	2.050 x 8.0 x 1.65	12.38	24.79
E	Water Recycling Tank	1	: 5.95 x 2.7 x 1.75	28.11	28.11

# Specifications of the Mechanical Equipment

**Table 4:**

## Specifications of the Mechanical Equipment

S.No	Description	Specifications
A	Mechanical Mixer	7.5 HP/7 KW with double cutting arrangement
B	Compressor	3 HP/3 KW Phase 3 Fauji Make
C	Slurry Pump	3 HP/3 KW

As mentioned earlier, the following equipment will be installed at the plant:

## Specifications of other Ancillary Items

**Table 5:**

### Specifications of the Ancillary Items

S.No	Description	Specifications
A	Main Digester Gas Dome	4 mm M.S. Sheet with FRP coating
B	Gas Pipeline	GI pipe Class C
C	Air Compressor Grid in Pre-Digesters	GI Pipe Class C
D	Bio-gas Balloon/ Bag for extra Gas Storage	Polyethylene Bags
E	Biogas Flame Arrestor	
F	Plumbing Accessories	Check Valves, Isolation Valves, Control Valves, etc
G	Shell & Tube Heat Exchangers	200 SS 304
H	Recycling Water Line	150 mm uPVC SH 40
I	Inspection Lids	Cast Iron
J	Burners	
K	Bucket Conveyor	
L	Solar Heater	
M	Small Incinerator for Non Recyclables	

### 6.3.3 Disposal by Modified Sanitary Landfill (MSLF)

Total wastes to be disposed of in MSLF = (Non-Degradable Waste part of A, B, C, D & E category (of Table – 13) waste per day	24.17	MT
30% of projected (final year) waste generation	30.90	MT
Maximum of above two	30.90	MT
Approximate Vol. of Solid Waste to be at Landfill site per day	61.80	CUM
Vol. of Solid Waste to be disposed off per year	22248.00	CUM
Assuming 52% compaction, compacted Vol. of Solid Waste	10679.04	CUM
It is recommended that the disposal will be done above ground level (area landfill) Let us consider that the total depth of MSLF is 20 M above GL. Earth cover 30 CM.		
So, Area required for yearly dumping	542.08	SQM
For 15 years required area will be	8131.25	SQM
Considering change in habits, increase land requirement by 10%	8944.37	SQM
Add service area @ 10%	9838.81	SQM
or Area in Acres	2.43	Acres
Land requirement for Bio-gas plant	0.6	Acres
So, total land require for bio gas plant and sanitary landfill	3.03	Acres

The landfill site is to be operated in phases because it allows the progressive use of landfill area, such that at any given time a part of the site will have final cover, a part being actively field, a part being prepared to receive waste and a part is undisturbed.

Each phase is designed for a period of 12 months. Phases are to be filled from the base to the final /intermediate cover and capped within the period leaving a temporary un-restored sloping phase.

In this case Landfill site area required to be develop in 3 phases each phase will be used for 5 years period; so area required for 5 years	2710	SQM
Cell size to be provided Length :	50	Mtr
Width :	20	Mtr
Contact Surface Area :	5510	SQM
Adding 30% extra for 5 years dumping :	7163	SQM

Linear will be provided on the contact surface area of the cell of each phase before the commencement of landfill operation. The cost of construction of linear for each phase (for 5 years dumping) has therefore been considered in the project cost.



# Economics of the Project

## Economics Based on Revenue Generation from Sorting of Recyclables

The Operation and Maintenance Cost and the Revenue Generation associated with Sorting and Sale of Recyclables are calculated and provided in the table below:

**Table 6:**

### Economics for Sorting and Selling of Recyclables

Economics - Sorting and Sale of Recyclables	
Operation and Maintenance Cost per month	
Workers (60)	Rs. 4,20,000
Supervisors (6)	Rs. 60,000
Safety Equipments and Additional Accessories	Rs. 50,000
Total O&M Cost per month	Rs. 5,30,000
Revenue Generation per day	
Sale of Recyclables (10 MT)	Rs. 80000
Revenue generated per month	Rs. 24,00,000

## Economics Based on Revenue Generation from Sorted Waste

The plant can have potentially two end products besides the organic fertilizer. It can generate biogas or it can generate electricity (using this gas in a generator). The economic viability of both the options is listed separately.

### Revenue generated using biogas as the final product

The table below shows the Revenue generated where Biogas is the final product

**Table 7:**

### Revenue Generation when Biogas is end product

<u>Case I: End Product: Biogas</u>		
Biogas Produced on Daily Basis:	1200	Kg
Revenue from Biogas sale	Rs. 30	per kg
Daily Revenue	Rs. 36,000	
Annual Revenue	Rs 1,29,60,000	

### Revenue generated using electricity as the final product

The table below shows the Payback analysis where Electricity is the final product

Table 8:

**Revenue Generation when Electricity is end product**

Case II: Electricity		
Plant Generator Rating	100	Kwh/T
Hours of Operation	10	hours per day
Energy Produced Daily	40 x 100 = 4000	KWH
Excess Electricity for Sell:	4000	KWH
Unit Price for Sell:	Rs. 7.5	per KWH
Daily Revenue	Rs. 30,000	
Annual Revenue	Rs. 1,08,00,000	

\*\* Besides the above revenue sources the city can gain some additional revenue from Organic Fertilizers. In several communities, with this type of systems, cities are selling this product to organic farmers and commercial crop growers. However, the proximity to tea plantations may prove to be a major factor for selling organic fertilizers. Based on experiences with the other system, if the city manages to identify appropriate customers it can generate revenue as shown below:

40 MT Waste generates around (10%) 4 MT or 4000 kg Organic Fertilizer

Rate of Organic Fertilizer= Rs. 3/kg

Revenue from Organic Manure= Rs. 12,000 per day.

Annual Revenue= Rs. 43,20,000

This additional revenue can be included to the above mentioned revenue alternatives, in case prospective buyers for organic manures are sourced.

From the tables above, we can easily project the Case I to be a more viable option. The table below presents the viability analysis for both the options.

Table 9:

**Viability analysis for both the options considered**

Parameters	Case I: Biogas as the end product	Case II: Electricity as the End Product
Buyers	Hotels, Restaurants, Hospitals, etc	Buyers are easily available and Electricity can be sold to the SEBs or can be used by the Municipality.
Transport and Supply	Biogas needs to be transported in specialized storage trucks, from source to site.	Electricity can be directed to the customers through Transmission Line
Plant Machineries at Source	Biogas can be extracted directly from the Gas Balloons. The process will involve daily filling up of the trucks with biogas and delivery of the gases to the individual storage units with the customers. This has to be done daily while following all the appropriate risk management protocols associated with transportation and storage of explosive gases in pressure vessels in public areas.	On the other hand, for Electricity Generation, Generators, Gas Turbines and other accessories are required, along with transmission lines.
Operation and	O &M Cost will involve maintenance	The O&M will involve some maintenance o

Maintenance	of the vehicles and depreciation involved along with the salary of the driver and maintenance crew.	the generators and gas cleaning equipment along with the depreciation of the equipment. The Generators depreciates with time. Thus more O & M Cost is involved
Economic Viability	It involves similar less Capital cost and yields slightly greater revenue	Capital cost is slightly higher, with similar revenue
Operational Risk	There is an inherent risk of an accident occurring during transportation and storage of the biogas in the pressure vessels either on the trucks or at the site of usage. That may happen with a road accident, or improper operation or any negligence. That may have some adverse impact on life and property over the long term. This will necessitate development and implementation of detailed risk management protocol by the Municipality	The entire system will be contained within the premises of the biogas plant and the electricity generated will be uploaded to the grid. Therefore there is no requirement of transportation of explosive gases on the public streets or storing gases in pressure vessels in public properties outside the site. Therefore, this alternative posses significantly less risk than the option of transportation of biogas as all risk is contained within the premises. Also, revenue collection is easier as revenue will be collected from a single source (Electric company)

Thus from the above table, generation and distribution of electricity is the safer alternative with an assured source of revenue. The daily operations is simple with minimum daily inputs.

### Bio-gas to Electric Generating Unit for 40 MT MSW Process Capacity Plant

The bio-gas generated from the waste in the main-digester is stored in tank located at site. The gas transferred to storage tank by a blower/compressor unit pass thru' a Scrubber. The bio-gas produced is generally have 30 to 35% of Carbon-di-oxide & 5 to 6% of moisture and some Hydrogen Sulphide which requires to be eliminated. This Scrubber works on elimination of these components. So a dry & pure bio-gas is transferred to the storage tanks.

This stored dry & pure bio-gas then drawn by a blower to pass thru' a de-humidifier cum chiller unit compatible to the process for conversion to electricity in the generator unit. Generally, 80 kWh power is generated from each MT of MSW processed. For 40 MT MSW process plant, 3 x125 KVA generating unit is required to be installed to take care of the energy produced.

The schematic below shows the process flow for conversion of bio-gas to electrical energy :

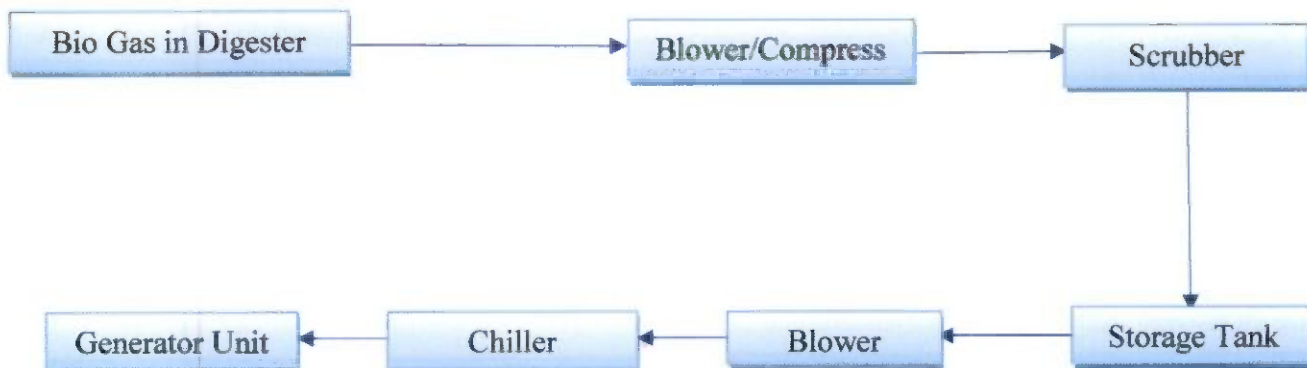

The Digesters, Blower/Compressors for transfer gas to storage tank & the storage tank is a part of main process plant. To convert the output usage to generate electricity, The Scrubber unit, The Blower, The Chiller and the Generator units are to be added in the plant system and are to be integrated in-line with the schematic shown above.



## **Brief Specification:**

### **A. Generator Unit:**

Capacity	: 100 kW, 3-phase
Fuel	: Bio-Gas
Engine Type	: 4 stroke, self-start, 1500/3000 RPM, SI engine
Power Factor	: 0.8
Engine Make	: Ashok Leyland / Equivalent
Alternator	: 125 kVA, Three/single phase, 415/230 Volts
Protection	: IP23
Sound Pressure Level	: 90 dB(A)
Cooling System	: Water Cooled

### **B. Scrubber cum Dehumidifier unit:**

Capacity	: 65 m <sup>3</sup> /hr
Pressure	: 50 – 100 mBar
Temperature	: Ambient
Gas-impurities to remove	: CO <sub>2</sub> /CO, H <sub>2</sub> S, SO <sub>2</sub> , H <sub>2</sub> O etc.
Scrubber type	: Chemical
Dehumidifier type	: Regenerative type bio-gas dehumidifier

### **C. Blower Unit:**

Capacity	: 100 m <sup>3</sup> /hr, 0.25 kg/cm <sup>2</sup>
Type	: twin-lobe
Motor rating	: 3 HP

## **Conclusion**

The proposal intends to offer an integrated solution for Solid waste management for the Purulia Municipal Area. The suggested alternative will create a regular sustainable solution in concern with "Zero Discharge" of waste along with generating electricity, thereby generating revenue on a regular basis.

Two revenue streams have been discussed; one with electricity and the other with fertilizer being generated on the daily basis.

The organic waste being generated (approximately 4 tons per day) also can be sold to the plantations and other entities interested in organic farming. The value for the organic waste has not been included in the payback analysis as the pricing for the end product is not clear for the surrounding market. However, once started, the project will certainly generate additional revenue from the fertilizer sales.

**The overall cost for setting up the system including the initial capital cost for the at source sorting operation is Rs. 930.15 Lakhs and total project cost estimated to the tune of Rs. 1459.54 Lakhs and the City will gain revenue from the gas or electricity sales, Organic fertilizers and some from the collection process.**

**Basic Ward wise Information : PURULIA MUNICIPALITY**

Annexure I

Ward No.	Area (sq. km.)	No. of Holdings	Population (2011)	Daily & Wholesale Market		Commercial centres		Hotels		Hospitals		Domestic Waste Collection System Followed	Market/ Commercial Waste Collection System Followed	Distance from the Dumping Ground (in Km.)
				No.	Appr. Quantity of Waste Generated (in mt)	No.	Appr. Quantity of Waste Generated (in mt)	No.	Total No. of Beds	No.	Total No. of Beds			
1	0.545	2172	6065			1	60							9
2	0.326	1262	5009											9
3	1.259	1953	5156			6	200	3	765					9
4	1.109	1469	4740	1	5									10
5	0.942	2102	4544			5	200							12
6	0.636	1700	5856											13
7	0.725	1896	7251											13
8	0.281	1081	6096											14
9	1.078	2361	8534											14
10	0.348	1443	7683											13
11	1.397	895	5545											14
12	0.205	881	3535											12
13	0.312	1257	1799	3	35	1	20							11
14	0.161	966	3616			1	30							11
15	0.136	573	2888											12
16	1.313	1493	6558											12
17	0.164	833	4369											11
18	0.401	1641	7215											10
19	0.119	877	3729											10
20	0.204	1112	4374											10
21	0.1249	2102	5822			3	80							9
22	0.944	1493	7109											14
23	0.166	639	3943											14
<b>Total</b>	<b>12.8959</b>	<b>32201</b>	<b>121436</b>	<b>4</b>	<b>40</b>	<b>0</b>	<b>0</b>	<b>17</b>	<b>590</b>	<b>3</b>	<b>765</b>			

Community Bin Collection

Community Bin Collection

## PURULIA MUNICIPALITY

### Annexure - II

Wardwise Population as per Census Year - 2011			
Ward No.	Population (Nos.)	House Holds (Nos.)	Area (Sq. Km.)
1	6065	2172	0.545
2	5009	1262	0.326
3	5156	1953	1.259
4	4740	1469	1.109
5	4544	2102	0.942
6	5856	1700	0.636
7	7251	1896	0.725
8	6096	1081	0.281
9	8534	2361	1.078
10	7683	1443	0.348
11	5545	895	1.397
12	3535	881	0.205
13	1799	1257	0.312
14	3616	966	0.161
15	2888	573	0.136
16	6558	1493	1.313
17	4369	833	0.164
18	7215	1641	0.401
19	3729	877	0.119
20	4374	1112	0.204
21	5822	2102	0.1249
22	7109	1493	0.944
23	3943	639	0.166
<b>Total</b>	<b>121436</b>	<b>32201</b>	<b>12.896</b>



**PURULIA MUNICIPALITY**

**Annexure - IIA**

<b>Zonewise Population as per Census Year - 2011</b>				
<b>Zone No.</b>	<b>Ward Nos.</b>	<b>Population (Nos.)</b>	<b>House Holds (Nos.)</b>	<b>Area (Sqm.)</b>
<b>A</b>	1,2, 3, 4, 5, 20, 23	33831	10709	4.551
<b>B</b>	6, 7, 8, 9	27737	7038	2.72
<b>C</b>	10, 12, 13, 14, 15,17,18,19	34834	8471	1.846
<b>D</b>	11, 16, 21, 22	25034	5983	3.7789
<b>Total</b>		<b>121436</b>	<b>32201</b>	<b>12.8959</b>

## PURULIA MUNICIPALITY

### Annexure - IIB

Growth Trend			
Arithmetic Increase Method			
Sl. No.	Year	Population	Increase in Population
	(1)	(2)	(3)
1	1981	74935	
			17154
2	1991	92089	
			21710
3	2001	113799	
			7637
4	2011	121436	
	Total		46501

$$\text{Average increase per decade (x)} = \frac{\text{Total increase in population}}{\text{Number of decades}}$$

$$\text{Hence, X} = \frac{46501}{3}$$
$$= 15500$$

Therefore, average rate of increase per decade with respect to population in the year of 2011,

$$x = 12.77 \%$$

## PURULIA MUNICIPALITY

### Annexure - IIC

Growth Trend				
Geometric Increase Method				
Sl. No.	Year	Population	Increase in Population	Percentage increase in population i.e. growth rate (r)
	(1)	(2)		(3)
1	1981	74935	17154	17154/ 74935 x 100 = 22.89 %
2	1991	92089		
3	2001	113799	21710	21710/ 92089 x 100 = 23.58 %
4	2011	121436	7637	7637/ 113799 x 100 = 6.71 %

The geometric mean of the growth rate (r) =  $(n-1)^{\text{th}}$  root of the multiplication of all 'r's

$$= (22.89 \times 23.58 \times 6.71) ^{1/3}$$

$$= 14.94$$



**PURULIA MUNICIPALITY**

**Annexure - IID**

Growth Trend				
Incremental Increase Method				
Sl. No.	Year	Population	Increase in Population in each decade	Incremental Increase i.e. increment on the increase
	(1)	(2)	(3)	(4)
1	1981	74935	17154	
2	1991	92089		
3	2001	113799	7637	
4	2011	121436		
Total =			46501	-9517

Average increase per decade ( X ) = 15500  
and average of incremental increases (Y) = -4758.5

Therefore, average rate of increase per decade with respect to population in the year of 2011,

$$x = 12.77 \%$$

and average rate of incremental increase per decade with respect to population in the year of 2011,

$$y = -3.92 \%$$

## PURULIA MUNICIPALITY

Annexure - IIE

### Computation of n values for different design years

Last known year	Future Year	Difference in years	Difference in decades (n)
(1)	(2)	(4)	(5) = Col. (4)/ 10
2011	Base year 2019	8	0.8
2011	Intermediate year 2029	18	1.8
2011	Final year 2039	28	2.8

### Computation of zonewise Projected Population in different design years

Zone No.	Population in last known census year (P <sub>0</sub> ) (2011)	Arithmetic Increase Method			Geometric Mean Method			Incremental Increase Method		
		x(%)			r (%)			x(%)		
		$P_n = P_0(1 + \frac{nx}{100})$			$P_n = P_0(1 + \frac{r}{100})^n$			$P_n = P_0\{1 + \frac{nx}{100} + n(n+1) \cdot \frac{y}{100 \times 2}\}$		
		Base Year	Intermediate Year	Final Year	Base Year	Intermediate Year	Final Year	Base Year	Intermediate Year	Final Year
<b>A</b>	33831	2019	2029	2039	2019	2029	2039	2019	2029	2039
<b>B</b>	27737	37288	41608	45928	37818	43468	49962	36333	38267	38876
<b>C</b>	34834	30571	34113	37655	31006	35638	40962	29789	31374	31873
<b>D</b>	25034	38393	42841	47290	38939	44757	51443	37410	39402	40028
<b>Total</b>	121436	27592	30789	33986	27984	32165	36971	26886	28317	28767
		133844	149351	164859	135747	156028	179338	130418	137360	139544
		12.77			14.94			-3.92		

# PURULIA MUNICIPALITY

Annexure - IIF

## Computation of zonewise Projected Population in different design years

Zone No.	Population (2011)	<u>Design Population (Average of three methods)</u>		
		Base Year	Intermediate Year	Final Year
		2019	2029	2039
A	33831	37146	41114	44922
B	27737	30455	33708	36830
C	34834	38247	42333	46254
D	25034	27487	30424	33241
<b>Total</b>	<b>121436</b>	<b>133336</b>	<b>147580</b>	<b>161247</b>



## PURULIA MUNICIPALITY

### Annexure - IIG

Projected waste generation			
Year	Projected Population	Projected waste generation as per Manual in MT	Projected waste generation considering present rate of the town in MT i.e. @0.64 kg/C/D
1	2	3	4
Base Year 2019	133336	28	85
Intermediate Year 2029	147580	31	94
Final Year 2039	161247	34	103

**Conclusions:**

1. As there are huge gap between manual provision and actual data collected from ULB(s) with respect to total generation of waste, the basic design is proposed considering present estimated generation i.e. 77 MT/Day except provision for sanitary land fill.
2. As the Bio gas plants are designed in modular manner hence another one or more module can be added as & when required. Provision of land for future expansion is earmarked.
3. Land for sanitary land fill is to be calculated on the basis of Final year generation of column 4 i.e. 30% of 103MT

**Table 3.1 Quantity of Municipal Solid Waste in Indian Urban Centres**

Population Range (in Millions)	Number of Urban Centres (sampled)	Total population (in Million)	Average capita value (kg/capita/day)	per quantity value (tonnes/day)
< 0.1	328	68.3	0.21	14343.00
0.1 - 0.5	255	56.914	0.21	11952.00
0.5 - 2.0	31	21.729	0.25	5432.00
1.0 - 2.0	14	17.184	0.27	4640.00
2.0 - 5.0	6	20.597	0.35	7209.00
> 5.0	3	26.306	0.50*	13153.00

\* 0.6 kg/capita/day generation of MSW has been observed in metro cities

Source: Manual on MSW Management 2000

Domestic Waste:

PURULIA MUNICIPALITY

Table - 10

Ward No.	Distance from the Dumping site (in KM.)	No. of Holdings	Population	Domestic Waste generate (in Kg.)	No. of Container (20 lit.) required	No. of Tyre-Mounted Wheel Barrow Required	Remarks
1	9	2172	6065	1668	217	43	In areas where house to house collection by wheel barrow will not be possible, combination of collection in community bin system and house to house collection by Wheel Barrow shall have to be adopted. Capacity of Community Bins - 200 lit.
2	9	1262	5009	1377	126	25	
3	9	1953	5156	1418	195	39	
4	10	1469	4740	1304	147	29	
5	12	2102	4544	1250	210	42	
6	13	1700	5856	1610	170	34	
7	13	1896	7251	1994	190	38	
8	14	1081	6096	1676	108	22	
9	14	2361	8534	2347	236	47	
10	13	1443	7683	2113	144	29	
11	14	895	5545	1525	90	18	
12	12	881	3535	972	88	18	
13	11	1257	1799	495	126	25	
14	11	966	3616	994	97	19	
15	12	573	2888	794	57	11	
16	12	1493	6558	1803	149	30	
17	11	833	4369	1201	83	17	
18	10	1641	7215	1984	164	33	
19	10	877	3729	1025	88	18	
20	10	1112	4374	1203	111	22	
21	9	2102	5822	1601	210	42	
22	14	1493	7109	1955	149	30	
23	14	639	3943	1084	64	13	
<b>TOTAL</b>		<b>32201</b>	<b>121436</b>	<b>33395</b>	<b>3219</b>	<b>644</b>	

1 wheel barrow will covered about 50 to 75 holdings

**Trade Waste : PURULIA MUNICIPALITY**

Table -11

Ward No.	Area (sq. Km.)	No. of Holdings	Population	Daily & Wholesale Market		Commercial centres		Hotels			Total Quantity of Waste Generated (MT)	Distance from the Dumping Ground (in Km.)
				No.	Appr. Quantity of Waste Generated ( MT )	No.	Appr. Quantity of Waste Generated ( MT )	No.	Total No. of Beds	Total Quantity of Waste Generated (MT)		
1	0.545	2172	6065					1	60	0.045	0.05	9
2	0.326	1262	5009					0	0	0	0.00	9
3	1.259	1953	5156					6	200	0.15	0.15	9
4	1.109	1469	4740	1	5			0	0	0	5.00	10
5	0.942	2102	4544					5	200	0.15	0.15	12
6	0.636	1700	5856					0	0	0	0.00	13
7	0.725	1896	7251					0	0	0	0.00	13
8	0.281	1081	6096					0	0	0	0.00	14
9	1.078	2361	8534					0	0	0	0.00	14
10	0.348	1443	7683					0	0	0	0.00	13
11	1.397	895	5545					0	0	0	0.00	14
12	0.205	881	3535					0	0	0	0.00	12
13	0.312	1257	1799	3	35			1	20	0.015	35.02	11
14	0.161	966	3616					1	30	0.0225	0.02	11
15	0.136	573	2888									12
16	1.313	1493	6558									12
17	0.164	833	4369									11
18	0.401	1641	7215									10
19	0.119	877	3729									10
20	0.204	1112	4374									10
21	0.125	2102	5822					3	80	0.06	0.06	9
22	0.944	1493	7109					0	0	0	0.00	14
23	0.166	639	3943					0	0	0	0.00	14
<b>TOTAL</b>	<b>12.9</b>	<b>32201</b>	<b>121436</b>	<b>4</b>	<b>40.0</b>	<b>0</b>	<b>0.0</b>	<b>17</b>	<b>590</b>	<b>0.4425</b>	<b>40.4425</b>	



**Clinical Waste : PURULIA MUNICIPALITY**

**Table - 12**

Ward No.	Area (sq. km.)	No. of Holdings	Population	Hospitals		Total Quantity of Clinical Waste Generated Daily ( MT )	Total Quantity of infectious & hazardous Waste Generated Daily (MT)	Total Quantity of non-hazardous Waste Generated Daily ( MT )	Total Quantity of hazardous & infectious Clinic Waste Generated in three days (MT)	Distance from the Dumping Ground (in Km.)
				No.	Total No. of Beds					
1	0.545	2172	6065	0	0	0.00	0.00	0.00	0.00	9
2	0.326	1262	5009	0	0	0.00	0.00	0.00	0.00	9
3	1.259	1953	5156	3	765	1.15	0.29	0.86	0.86	9
4	1.109	1469	4740	0	0	0.00	0.00	0.00	0.00	10
5	0.942	2102	4544	0	0	0.00	0.00	0.00	0.00	12
6	0.636	1700	5856	0	0	0.00	0.00	0.00	0.00	13
7	0.725	1896	7251	0	0	0.00	0.00	0.00	0.00	13
8	0.281	1081	6096	0	0	0.00	0.00	0.00	0.00	14
9	1.078	2361	8534	0	0	0.00	0.00	0.00	0.00	14
10	0.348	1443	7683	0	0	0.00	0.00	0.00	0.00	13
11	1.397	895	5545	0	0	0.00	0.00	0.00	0.00	14
12	0.205	881	3535	0	0	0.00	0.00	0.00	0.00	12
13	0.312	1257	1799	0	0	0.00	0.00	0.00	0.00	11
14	0.161	966	3616	0	0	0.00	0.00	0.00	0.00	11
15	0.136	573	2888	0	0	0.00	0.00	0.00	0.00	12
16	1.313	1493	6558	0	0	0.00	0.00	0.00	0.00	12
17	0.164	833	4369	0	0	0.00	0.00	0.00	0.00	11
18	0.401	1641	7215	0	0	0.00	0.00	0.00	0.00	10
19	0.119	877	3729	0	0	0.00	0.00	0.00	0.00	10
20	0.204	1112	4374	0	0	0.00	0.00	0.00	0.00	10
21	0.1249	2102	5822	0	0	0.00	0.00	0.00	0.00	9
22	0.944	1493	7109	0	0	0.00	0.00	0.00	0.00	14
23	0.166	639	3943	0	0	0.00	0.00	0.00	0.00	14
<b>TOTAL</b>	<b>12.896</b>	<b>32201</b>	<b>121436</b>	<b>3</b>	<b>765</b>	<b>1.15</b>	<b>0.29</b>	<b>0.86</b>	<b>0.86</b>	

There are 15 Nos. Private Clinic, 55 nos. Pathological Laboratories. Total quantity of waste generated from those establishment will be about 100 kg.

Note: i) Assumed that Clinical Waste generated @ 1500 gm per bed.

ii) 25 % of the Clinical Waste generated is infectious in nature

**PURULIA MUNICIPALITY**  
**Estimation of Total Waste Generation Per Day in the Town**

Table - 13

Category	Generation Points	Total (in kg.)	Quantity of Waste (in Kg.)		Remarks
			Bio-degradable	Non-degradable	
<b>A</b>	Domestic	33395	20037	13358	To be transported to Bio Gas / Compost plant site except the non-degradable portion of domestic and hotel waste
	Daily & Wholesale Market	40000	32000	8000	
	Hotels	443	177	266	
	Agricultural/ Garden	500	500	0	
	<b>Sub-total</b>	<b>74337</b>	<b>52714</b>	<b>21623</b>	
<b>B</b>	Commercial Centres	0		0	To be transported to land fill Site
	Railway Station	500		500	
	Bus Stand	100		100	
	<b>Sub-total</b>	<b>600</b>		<b>600</b>	
<b>C</b>	Street Sweepings	500		500	do
	Drain Cleanings	300		300	
	<b>Sub-total</b>	<b>800</b>		<b>800</b>	
<b>D</b>	Cess pool	600	600		To be transported to trenching site
<b>E</b>	Clinical	1148		1148	To be transported to secured burial site
	<b>Total</b>	<b>77485</b>	<b>53314</b>	<b>24171</b>	

- Note:**
- i) Domestic SW contains about 60% organic matter and remaining 40% is inert materials
  - ii) Moisture content in organic waste is about 50%
  - iii) Hotels generate SW @750gm/bed and contains about 50% organic matter and remaining 50% is inert materials
  - iv) Market SW contains about 80% bio degradable matter and remaining 20% is inert materials
  - v) Assumed that trade waste contains about 10% bio degradable matter and remaining 90% is inert materials
  - v) Assumed that Agricultural waste contains about 100% bio degradable matter neglecting the very few inert materials
  - vi) In hospital waste
    - a) Infectious & hazardous waste is 0.287 MT
    - b) Non-hazardous waste is 0.861 MT







**Abbreviations :**

<b>LB :</b> Litter Bins ( about 20 to 40 lit capacity)	<b>TS :</b> Transfer Station
<b>HLD :</b> Hook Lift Dumper Container ( 5 - 7.5 Cum. capacity )	<b>ComM</b> Compactor( Mobile)
<b>HLD :</b> Hook Lift Dumper Carrier (Hydraulic)	<b>SLSJM:</b> Sewer Line suction cum Jetting Machine
<b>HDT :</b> Hydraulic Dumper Truck	<b>RSM :</b> Road Sweeping Machine
<b>CB :</b> Community Bins (200 lits.)	<b>TR:</b> Tractor
<b>WB:</b> Wheel Barrow	<b>RT:</b> Covered Refused Trailer with Hydraulic system

**Note:**

- I) SLSJM - 1 no., RSM - 1 no. HDT or ordinary truck - 2 nos, 1 tractor & 2 trailer are to be kept and maintained by Central Office and shall be deployed as per the requirement to various Zones to cater unscheduled generation of waste such as waste from festival houses / fairs, garden waste, construction debris etc.
- II) Construction Debris is to be carried by hydraulic dumper truck or by ordinary truck as per user charge basis.
- III) Hook Lift Dumper Containers (HLD) may be kept near all market places and that will be lifted by Hook Lift Dumper Carrier (HLD) for transportation to dumping ground.
- IV) Wheel Barrow will collect the domestic waste from door to door and also the waste from litter bins and transfer the same to the community bins or hydraulic dumper containers kept at suitable points.
- V) There must be 2 community bins at a place; 1 green for bio-degradable waste and 1 yellow for non-degradable waste.
- VI) Hook Lift Dumper Carrier (Hydraulic) will go on lifting the waste from the community bins kept at specified places and also the waste from the hotels stored in the containers and transport the same to dumping ground. In areas where quantity of waste is less the waste can be lifted on alternate days.
- VII) Provide atleast one 200 ltrs. Bins at each commercial centres.
- VIII) Every hotel should keep 1 green container and 1 yellow container for storing their degradable & non-degradable waste respectively which should be collected daily by municipality. No road side vat should be allowed for dumping the hotel waste.

# TYPES OF VEHICLES TO BE USED FOR COLLECTION AND TRANSPORTATION OF MUNICIPAL SOLID WASTE AT PURULIA MUNICIPALITY

1. House to House Collection



2. Hand Cart / Wheel Barrow



3. Transfer of SW after Collection through Wheel Barrow



4. Litter Bins (LB)

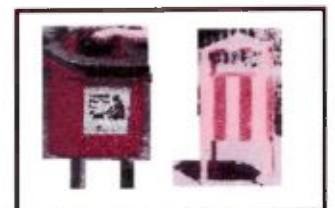

5. CGB: Community Garbage Bins (1000 ltr.; Steel bins with swivel castor wheels automatic lifting arrangement)



6. Cess- Pool Emptier



7. **Hydraulic Dumper Container  
(HDC)**



8. **Hook Lift / Hydraulic Dumper Carrier / Skip  
(HLD)**



9. **Tractor & Cover Refused Trailer  
with Hydraulic system  
(TR & RT)**



10. **Hydraulic Dumper Truck  
(HDT)**



11. **Road Sweeping Machine  
(RSM)**



12. **Sewer Line Suction cum Jetting Machine  
(SLSJM)**





**ABSTRACT COST ESTIMATE**

**Table - 15**

Sl. No.	Particulars	Amount (Rs. in lakh)
1	Plant, Machinery, Equipments for Collection, Transportations and Disposal	381.29
2	Development of Land Fill Site	105.60
4	Construction of Bio-gas Plant	930.15
	<b>Total</b>	<b>1417.03</b>
	Contingencies @ 3%	42.51
	<b>Grand Total</b>	<b>1459.54</b>

  
**Shamim Dad Khan**  
Chairman  
Purulia Municipality

## REQUIREMENT OF VEHICLES AND ACCESSORIES

Table - 15A

Sl. No.	Particulars	Total Requirements	Remarks
1	Litter Bins (20 - 40 lit.)	249	
2	Hook Lift Dumper Container ( HLDC 5 - 7.5 Cum. capacity )	23	
3	Hook Lift Dumper Carrier (Hydraulic)- HLD	4	
4	Community Bins (200 lit. capacity)	110	
5	House to House Collection Bucket	64402	
6	Tractor	12	
7	Covered Refuse Trailer with Hydraulic system	23	
8	Pay-Loader/Bull-dozer	1	
9	Hydraulic Dumper Truck - HDT / Ordinary Truck	4	
10	Cess Pool Emptier	4	
11	Sewer Line suction cum Jetting Machine	1	
12	Road Sweeping Machine	1	
13	Wheel Barrow	505	
14	Compactor (mobile)	1	
15	Compactor (stationary)	0	
16	Shovels	300	
17	Spade	300	
18	Gloves , Masks, Gombboot etc.		LS
<b>Note:</b>			
i) Assuming one Wheel Barrow will cover in an average 65 nos. holdings.			
ii) House to house bucket shall be supplied to each family only once. Replacement of those bucket whenever required due to damage shall have to be arranged by the individual family.			
iii) Community Bins should have necessary arrangement for tilting the same, either manually or mechanically, for transferring waste directly to the transportation vehicles			

## ADDITIONAL REQUIREMENT OF VEHICLES AND ACCESSORIES

Table - 15B

Sl. No.	Particulars	Total Requirement	Existing nos.	Additional Requirement	Rate (Rs.)	Amount (Rs.)	Remarks
			Total				
1	Litter Bins	249		249	1560	388440	
2	Hook Lift Dumper Container ( HLDC 5 - 7.5 Cum. capacity )	23	16	7 ✓	90000	630000	
3	Hook Lift Dumper Carrier (Hydraulic)- HLD	4		4 ✓	2473200	9892800	
4	Community Bins (200 lit. capacity)	110	55	55	9875	543125	
5	House to House Collection Bucket	64402		64402	86	5538572	
6	Tractor	12	12	0	850000	0	
7	Covered Refuse Trailer with Hydraulic system	23	9	14 ✓	150000	2100000	
8	Pay-loader/Bull-dozer	1		1 ✓	4500000	4500000	
8	Hydraulic Dumper Truck - HDT / Ordinary Truck	4	3	1 ✓	200000	200000	No road side open vat should be allowed.
9	Cess Pool Emptier (Tanker-Trailer fitted with suction pump)	4	3	1 ✓	1050000	1050000	1 Cess-pool Emptire - on tanker-trailers suitable for narrow lane is required to be provided
10	Sewer Line suction cum Jetting Machine	1		1 ✓	1200000	1200000	
11	Road Sweeping Machine	1		1 ✓	3000000	3000000	
12	Wheel Barrow	505	50	455	9850	4481750	
14	Compactor (mobile)	1		1 ✓	4300000	4300000	
13	Compactor (stationary)	0		0	10000000	0	
14	Shovels	300		300	380	114000	
15	Spade	300		300	300	90000	
16	Gloves , Masks, Gombot etc.	0				100000	
					<b>TOTAL</b>	<b>38128687</b>	
					<b>Say Rs.</b>	<b>381.29</b>	lakh



## Cost of Development of LandFill Site

Table - 15C

SL. NO.	PARTICULARS	AMOUNT
		Rs. (in lakh)
1	Construction of Approach Road to landfill site 500 mt. length width 3.5m. @ Rs. 3220 per m.	16.1
2	Site Development	20.0
3	Cost of providing linear (for 5 years dumping)	20.0
4	Construction of protection wall (CRM)	15.0
5	Construction of surface run-off diversion drain	10.0
6	Construction of leachate circulation & treatment system at Landfill site	20.0
7	Tree plantation	1.5
8	Construction of Site Office	3.0
	<b>TOTAL</b>	<b>105.60</b>

## Estimated Cost for Bio gas Plant

Table - 15D

Sl No.	Item	Cost (in Rs.)
1	Civil Cost	29,255,618.27
2	Sorting facility	1,333,333.33
2	Mechanical	42,959,052.32
3	Gas storage	10,800,000.00
4	Gas to Electricity Generating System	8,666,700.00
	<b>TOTAL (Rs.)</b>	<b>93,014,703.92</b>

Total Tonnage of Bio- Degradable waste	53.31 MT
Total Tonnage to be Processed	50.00 MT
<b>Recommended layout:</b>	8 Units @5 MT/Units
Total System tonnage	40 MT

Table - 15E

ESTIMATE OF CIVIL WORK FOR 60 MT FOUNDATION AND COLUMNS, BEAMS; SLABS FOR PROP. BIOGAS LAYOUT						
SL No	Description	Page Ref	Quantity	Unit	Rate (in Rs.)	Amount (in Rs.)
1	Earth work in excavation of foundation trenches or drains, in all sorts of soil (including mixed soil but excluding laterite or sandstone) including removing, spreading or stacking the spoils within a lead of 75 m. as directed. The item includes necessary trimming the sides of trenches, levelling, dressing and ramming the bottom, bailing out water as required complete. (a) Depth of excavation not exceeding 1,500 mm.	BUILDING WORKS 2015 P-1 It-2.a	1720.00	m3	120.47	207,208
2	Earth work in filling in foundation trenches or plinth with good earth, in layers not exceeding 150 mm. including watering and ramming etc. layer by layer complete. (Payment to be made on the basis of measurement of finished quantity of work) (a) With earth obtained from excavation of foundation	BUILDING WORKS 2015 P-1 It-3.a	346.67	cu.m	78.31	27,147
3	Ordinary Cement concrete (mix 1:2:4) with graded stone chips (20 mm nominal size) excluding shuttering and reinforcement, if any, in ground floor as per relevant IS codes. (b) River bazree	BUILDING WORKS 2015 P-12 It-3.b	146.67	cu.m	7,116.00	1,043,680
4	Ordinary Cement concrete (mix 1:1.5:3) with graded stone chips (20 mm nominal size) excluding shuttering and reinforcement if any, in ground floor as per relevant IS codes (ii) River Bazree	BUILDING WORKS 2015 P-15 It-7.ii	1555.56	cu.m	8,150.40	12,678,400
5	Hire and labour charges for shuttering with centering and necessary staging upto 4 m using approved stout props and thick hard wood planks of approved thickness with required bracing for concrete slabs, beams and columns, lintels curved or straight including fitting, fixing and striking out after completion of works (upto roof of ground floor) (c) Steel shuttering or 9 to 12 mm thick approved quality ply board shuttering in any concrete work	BUILDING WORKS 2015 P-27 It-12.c	7333.33	sq.m	490.80	3,599,200
6	125 mm. thick brick work with 1st class bricks in cement mortar (1:3) in ground floor.	BUILDING WORKS 2015 P-32 It-30	2666.67	sq.m	1,149.60	3,065,600
7	Reinforcement for reinforced concrete work in all sorts of structures including distribution bars, stirrups, binders etc initial straightening and removal of loose rust (if necessary), cutting to requisite length, hooking and bending to correct shape, placing in proper position and binding with 16 gauge black annealed wire at every intersection, complete as per drawing and direction. (i) Tor steel/Mild Steel	BUILDING WORKS 2015 P-28 It-15.i	89.33	MT	75,680.40	6,760,782
8	Plaster (to wall, floor, ceiling etc.) with sand and cement mortar including rounding off or chamfering corners as directed and raking out joints including throating, nosing and drip course, scaffolding/staging where necessary (Ground floor).[Excluding cost of chipping over concrete surface] (iii) With 1:3 cement mortar (b) 15 mm thick plaster	BUILDING WORKS 2015 P-164 It-15.i	6666.67	sq.m	243.60	1,624,000
9	Neat cement punning about 1.5mm thick in wall,dado,window sill,floor etc. NOTE:Cement 0.152 cu.m per100 sq.m.	BUILDING WORKS 2015 P-166 It-8	5333.33	sq.m	46.80	249,600
<b>Total</b>						<b>29,255,618</b>



Table - 15F

## ESTIMATE OF MECHANICAL WORK

Item	Specification	Qty	Rate (in Rs.)	Amount (in Rs.)
Blower	TWIN LOBE 10 HP KSB	8	82813	662,504.00
Mixer	7.5 HP	8	225000	1,800,000.00
Sludge Pump	KIRLOSKAR 250 L WITH 3 HP MOTOR	8	21000	168,000.00
Solar Panel	EVACUATED GLASS TUBE WHS	8	71543	572,344.00
Balloon	120 CU.M	0	168750	0.00
Compressor	5 HP CROMPTON GREAVES	8	63000	504,000.00
Generator	For electricity	2	2000000	4,000,000.00
Piping	AS PER REQ	LUMPSUM	7500000	7,500,000.00
Steel Tank	Per Kg	153,082.99	135	20,666,204.32
Installation for Fabrication (Bamboo Scaffolding incl of Labour)			300000	300,000.00
Submersible Pump	KSB MAKE	8	39900	319,200.00
Gas Burner	BIOGAS	8	8500	68,000.00
Gas Meter	BIOGAS	8	17850	142,800.00
pH Meter		8	7000	56,000.00
Electricals		LUMPSUM	3000000	3,000,000.00
Protective Coating	GLASS EPOXY COATING	LUMPSUM	800000	800,000.00
Transportation			400000	400,000.00
Shed for Sorting Area and Control Panel (sq.ft)	Working Shed	5000	200	1,000,000.00
Small Incinerator		2	500000	1,000,000.00
			<b>Total</b>	<b>42,959,052.32</b>

**Steel Calculations for 25 MT**

	Main Digester	Pre Digester 1	Pre Digester 2	
Outer Radius	2.7	1.25	1.25	
Thickness	0.008	0.008	0.008	
Inner Radius	2.692	1.242	1.242	
Depth	6	4	4	
Volmof Top Plate	<b>0.1831248</b>	<b>0.03925</b>	<b>0.03925</b>	cu.m
Volm of Bottom Plate	<b>0.1831248</b>	<b>0.03925</b>	<b>0.03925</b>	cu.m
Volm of Tank out	137.3436	19.625	19.625	cu.m
Volm of Tank in	136.5309178	19.37460384	19.37460384	cu.m
Tank Shell Volume	<b>0.81268224</b>	<b>0.25039616</b>	<b>0.25039616</b>	cu.m
Total Shell Volum	1.17893184	0.32889616	0.32889616	cu.m
Total steel	8606.202432	2400.941968	2400.941968	kg
baffle	0.48456	0.15	0.15	
baffle steel wt each tank	3,537	1,095	1,095	
Total steel Including Baffle	12,143	3,496	3,496	
Number of tanks		8		
<b>Total Steel wt</b>		<b>153,082.99</b>		

**Table - 16**

**ESTIMATION OF LABOUR COST FOR HOUSE TO HOUSE COLLECTION**

SL.NO.	HEAD	NOS.	RATE PER MONTH (Rs.)	AMOUNT (Rs.)
1	For House to House collector	50	4500	225000
2	Supervisor for House to House collection	5	6000	30000
<b>TOTAL</b>				<b>255000</b>



Table - 17

### Operation and Maintenance Cost for Biogas plant

Categories	Unit	Quantity	Rate	Expenses Per Month
<b>A. Labour</b>				
1. Bio Gas Operators	Each	4.00	7,000.00	28,000.00
2. Supervisor	Each	2.00	10,000.00	20,000.00
3. Chemist	Each	0.25	15,000.00	3,750.00
4. Administration Charges	Lump sum			5,000.00
5. Regular visit charges of technical experts for technical support	Per Visit	1 per 2 month	10,000.00	5,000.00
Sub-Total for Manpower on Monthly Basis				61,750.00
<b>B. Ancillary Items</b>				
1. Upkeep & maintenance charges. (Apron, hand gloves, mask, gumboot, cap, phenyl, liquid soap, soap, duster, hard broom, soft broom, first aid kit, spade, water pipe.	Lump sum			10,000.00
2. Repairs & replacement of machinery parts, changing of oil and mixer and compressor belts.	Lump sum			10,000.00
3. Miscellaneous	Lump sum			5,000.00
Sub-Total for Ancillary Items				25,000.00
<b>C. Electricity</b>				
Average projected Electricity consumption is 10 KWH per ton	kwh	400.00	6.00	72,000.00
Monthly cost				158,750.00
<b>Total Operation &amp; Maintenance Cost per Year</b>				<b>1,905,000.00</b>

# PURULIA MUNICIPALITY

## ESTIMATION OF OPERATIONAL COST OF TRANSPORTATION

Transportation expenditure includes carrying cost of garbage per day from the spot of collection to Dumping Station cum Bio-gas Plant. The estimate for running cost of each type of prime- movers is given below :

Assume cost of Diesel = Rs. 60 /Lit

Cost of Lubricant = Rs. 264 /Lit

Table -18A

### 1. DUMPER TRUCK / ORDINARY TRUCK

Speed of Vehicle -	20 KM/Hr
Average Distance of dumping site is	2 KM
Parking Distance -	2 KM
Carrying capacity -	5 MT
No. of trips / day/ vehicle (8 hrs. working shift) is	2
Total Km done / day =	12 KM

HEAD	CONSUMPTION SPECIFICATION	QUANTITY	RATE (Rs.)	AMOUNT (Rs.)
Diesel	@ 6 Km/lt.	2 ltr.	60 per ltr.	120.00
Lubricant	@ 100 Km/lt.	0.1 ltr.	264 per ltr.	31.68
Labour	For loading & unloading	2 nos.	150 per head/day	300.00
Truck Driver	One	1 nos.	400 per head/day	400.00
Truck Cleaner	One	1 nos.	150 per head/day	150.00
				<b>1001.68</b>
<b>say</b>				<b>1002</b>

Table - 18B

### 2. TRACTOR

Speed of Vehicle -	20 KM/Hr
Average Distance of dumping site is	2 KM
Parking Distance -	2 KM
Carrying capacity -	3 MT
No. of trips / day/ vehicle (8 hrs. working shift) is	3
Total Km done / day =	16 KM

HEAD	CONSUMPTION SPECIFICATION	QUANTITY	RATE (Rs.)	AMOUNT (Rs.)
Diesel	@ 6 Km/lt.	2.7 ltr.	60 per ltr.	160.00
Lubricant	@ 100 Km/lt.	0.2 ltr.	264 per ltr.	42.24
Tractor Driver	One	1 nos.	300 per head/day	300.00
Tractor Cleaner cum unloader	One	1 nos.	150 per head/day	150.00
				<b>652.24</b>
<b>say</b>				<b>652</b>

Table - 18C

### 3. HOOK LIFT DUMPER CARRIER (HLD)

Speed of Vehicle -	20 KM/Hr
Average Distance of dumping site is	2 KM
Parking Distance -	2 KM
Carrying capacity -	5 MT
No. of trips / day/ vehicle (8 hrs. working shift) is	2
Total Km done / day =	12 KM

HEAD	CONSUMPTION SPECIFICATION	QUANTITY	RATE (Rs.)	AMOUNT (Rs.)
Diesel	@ 6 Km/lt.	0.3 ltr.	60 per ltr.	20.00
Lubricant	@ 40 Km/lt.	0.1 ltr.	264 per ltr.	13.20
Driver	One	1 nos.	400 per head/day	400.00
Cleaner / Loader	Two	2 nos.	150 per head/day	300.00
				<b>733.20</b>
<b>say</b>				<b>733</b>

**4. MOVABLE COMPACTOR**

Speed of Vehicle -	20 KM/Hr
Average Distance of dumping site is	2 KM
Parking Distance -	2 KM
Carrying capacity -	10 MT
No. of trips / day/ vehicle (8 hrs. working shift) is	2
Total Km done / day =	12 KM
Actual hour of operation	4 Hrs.

HEAD	CONSUMPTION SPECIFICATION	QUANTITY	RATE (Rs.)	AMOUNT (Rs.)
Diesel : For Movement	@ 3 Km/lt.	4 ltr.	60 per ltr.	240.00
Diesel : For Operation	@ 6 lit/hr.	24 ltr.	60 per ltr.	1440.00
Lubricant	@ 40 Km/lt.	0.4 ltr.	264 per ltr.	105.60
Driver	One	1 nos.	500 per head/day	500.00
Cleaner	One	1 nos.	200 per head/day	200.00
				<b>2485.60</b>
			<b>say</b>	<b>2485.6</b>

Table - 18E

**5. ROAD SWEEPING MACHINE**

Speed of vehicle - 8 Km per hr.
Average Distance to be travelled per day 15 Km.

HEAD	CONSUMPTION SPECIFICATION	QUANTITY	RATE (Rs.)	AMOUNT (Rs.)
Diesel	For 15 km @ 5 Km/lt.	3 ltr.	60 per ltr.	180.00
Lubricant	For 15 km @ 40 Km/lt.	0.3 ltr.	264 per ltr.	79.20
Driver	One	1 nos.	400 per head/day	400.00
Cleaner	One	1 nos.	150 per head/day	150.00
				<b>809.20</b>
			<b>say</b>	<b>809</b>

Table - 18F

**6. PAY LOADER / BULL DOZER**

Average Distance to be travelled per day 8 Km.
Actual hour of operation 4 hrs.

HEAD	CONSUMPTION SPECIFICATION	QUANTITY	RATE (Rs.)	AMOUNT (Rs.)
Diesel : For Movement	For 8 km @ 5 Km/lt.	1.80 ltr.	60 per ltr.	108.00
Diesel : For Operation	For 4 hrs. @ 3 lit/hr.	12 hr.	60 per ltr.	720.00
Lubricant	For 10 km @ 40 Km/lt.	0.4 ltr.	264 per ltr.	105.60
Driver	One	1 nos.	500 per head/day	500.00
Cleaner	One	1 nos.	150 per head/day	150.00
				<b>1583.60</b>
			<b>say</b>	<b>1583.6</b>

Table - 18G

**7. CESS POOL EMPTIER**

Average Distance to be travelled per day 20 Km.
Actual hour of operation 2 hrs.

HEAD	CONSUMPTION SPECIFICATION	QUANTITY	RATE (Rs.)	AMOUNT (Rs.)
Diesel : For Movement	For 20 km @ 8 Km/lt.	1.2 ltr.	60 per ltr.	72.00
Diesel : For Operation	For 2 hrs. @ 2 lit/hr.	4 hr.	60 per ltr.	240.00
Lubricant	For 20 km @ 40 Km/lt.	0.5 ltr.	264 per ltr.	132.00
Driver	One	1 nos.	400 per head/day	400.00
Cleaner	One	1 nos.	150 per head/day	150.00
				<b>994.00</b>
			<b>say</b>	<b>994</b>



**Total Cost of Transportation per day**  
**(excluding the cost of depreciation & cost of capital)**

**Table - 19**

PARTICULARS	COST PER DAY (Rs.)	NO.	TOTAL DAILY COST (Rs.)	MONTHLY COST (Rs.)	YEARLY COST (Rs.)
DUMPER TRUCK / ORDINARY TRUCK	1002	4	4006.72	120201.6	1442419.2
TRACTOR	652	12	7826.88	234806.4	2817676.8
HOOK LIFT DUMPER CARRIER	733	4	2932.8	87984	1055808
MOVABLE COMPACTOR	2485.6	1	2485.6	74568	894816
ROAD SWEEPING MACHINE	809	1	809.2	24276	291312
PAY LOADER / BULL DOZER	1584	1	1583.6	47508	570096
CESS POOL EMPTIER	994	4	3976	119280	1431360
<b>TOTAL</b>			<b>23621</b>	<b>708624</b>	<b>8503488</b>

So, total monthly cost of transportation of solid waste (excluding the cost of depreciation & cost of capital) of the town is Rs. 708624/- only.

**Table - 20****ESTIMATION OF TOTAL O & M COST FOR SOLID WASTE MANAGEMENT SYSTEM**

SL.NO.	PARTICULARS	AMOUNT PER MONTH (Rs.)	AMOUNT PER YEAR (Rs.)	Remarks
1	Operation cost of vehicles	708624	8503488	
2	Maintenance cost of vehicle	381287	4575442	
3	O & M cost for Landfill Operation	8800	105600	
4	Labour cost for bio-gas composting	158750	1905000	
5	Cost for Sorting and Selling of Recyclables	530000	6360000	
6	Labour cost for collection	255000	3060000	
7	Cost of depreciation of vehicles & Plant & Machinery @20%	6355	76257	
8	Cost of consumables	5000	60000	
9	Cost of fuel & energy	10000	120000	
10	Marketing Expenses	5000	60000	
11	Miscellaneous	5000	60000	
<b>TOTAL</b>		<b>2073816</b>	<b>24885788</b>	
		<b>Say Rs.</b>	<b>248.86</b>	<b>lakh</b>

# RECOMMENDATIONS

## PROPOSED SOLID WASTE MANAGEMENT SYSTEM FOR PURULIA MUNICIPALITY

### PROCEDURE TO BE FOLLOWED BY PURULIA MUNICIPALITY

#### 1) SEGREGATION OF MUNICIPAL SOLID WASTES

- ▶▶ Segregation of Bio-degradable & non-degradable wastes should be done at source. However a sorting operation also to be done before feeding Bio-gas plants to ensure smooth functioning.
- ▶▶ This should be made possible by vigorous awareness Campaign and by group meetings in each Ward, announcements, leaflets etc. prior to launching of the project and thereby ensuring community participation. Ward level S.W.M. Committees should be the instrumental in this matter.
- ▶▶ Provide two polythene containers, preferably not suitable for storage of liquid, one is Green another is Yellow to each family for collection of bio-degradable SW and non-degradable SW respectively.

*(The containers shall be supplied by the Municipality once only. Replacement of the containers if required subsequently shall be arranged by the individual occupiers of the holdings themselves. For convenient Municipality may arranged to sale those containers to the tax-payers)*

- ▶▶ Segregation of Bio-medical wastes should be done as per prescribed rules.

{*Note: Bio-degradable SW means which are basically organic in nature and biologically degradable which includes kitchen waste, fruit & vegetable waste, food waste, leaves & trees, agricultural waste, discarded cloths, papers, wood etc. and non-degradable SW are basically inorganic in nature and biologically not degradable it includes plastic & PVC items, PET Bottles, metal & metal foils, ashes, cinders, stones, bricks etc.*}

#### 2) COLLECTION OF MUNICIPAL SOLID WASTES

- ▶▶ Each ward should be divided into 2 & 3 beats comprising of 175 – 200 waste generating points which include Domestic units, Shops, Hotels & Restaurants and other Commercial Establishments.
- ▶▶ For ach beat there should be one Collector and a lady Supervisor for the whole ward i.e. for two or three beats.
- ▶▶ One Wheel Barrow or Three wheeled Motor Van may be provided for 2 or more beats as per the requirement.
- ▶▶ Solid wastes shall have to be collected every day between 7 a.m. to 10 a. m. by the Collectors by blowing whistle. Segregation of bio-degradable and non-degradable wastes are to be done at source.



- ▶▶ Each residential /domestic unit should be provided with two containers – one for bio degradable wastes and the other for non bio-degradable wastes in **Green & Yellow** containers respectively. Wastes from those containers should be collected in separate bins on the wheel barrows.
- ▶▶ For house to house collection of solid waste involvement of NGO's is to be encouraged. Persons from BPL families of that locality or nearby localities may be involved for house to house collecting of solid waste.
- ▶▶ They may be allowed to collect Rs. 30/- from APL families to Rs. 10/- from each BPL family for house to house collecting of solid waste. All implements for collection of solid waste should be provided by the municipal authority. (This will not only reduce the cost of collection on the part of civic body but will also ensure effective and efficient cleaning system.)
- ▶▶ Uprooted plants, grass and cut branches of trees and leaves should be collected separately.
- ▶▶ After collection the solid waste it should be carried to transporting vehicle posted at transfer stations.
- ▶▶ Bio-degradable wastes and non-degradable wastes should be transported separately by covered vehicles.
- ▶▶ By 2 p.m. each day the bio-degradable wastes are to be carried to the composting site and the trailers with non-degradable wastes are to be carried to the landfill sites for disposal.
- ▶▶ The whole operation is to be monitored by Ward level Solid Waste Management Committees specially formed jointly by public and Municipal Administrators
- ▶▶ Littering of wastes in streets and drains shall have to be stopped by providing litter bins at suitable locations.

### **3) STORAGE OF MUNICIPAL SOLID WASTES**

- ▶▶ Solid Wastes is to be stored by the waste generators in two separate bins of different colour provided for them by the Municipality and that should be collected within 24 hours.
- ▶▶ Storing of wastes in Vats or dumping by the road side should be prohibited. Road side Vats should be gradually turned into flower or plant pots. Where house to house collection is not possible Community bin collection method is to be adopted.
- ▶▶ After collection of solid waste it should be taken straight to the waiting trailers / Dumpers / truck at transfer stations.
- ▶▶ Colour Codes of Collection bins and trailers should be strictly followed.

#### **4) TRANSPORTATION OF SOLID WASTES**

- ▶▶ From waste generating points waste should be transferred to the transfer stations i.e two wheeled refuse trailers /Dumper or covered truck by specially designed Wheel Barrows. The vehicles either should have to compartments each for bio-degradable and non-degradable waste or there should be separate vehicles for bio-degradable and non-degradable waste for transportation. **Compactors to be used for non-bio degradable wastes.**
- ▶▶ Raised platforms i.e. ramp are to be built for hauling of wheel barrows / bins up to the height of transfer stations to make collection cleaner and to avoid multiple handling of Waste.
- ▶▶ Transfer stations should be carried by the prime movers straight to the sites in a train within 2/3 hours.

#### **5) PROCESSING OF WASTES**

- ▶▶ Bio-degradable wastes mainly Kitchen trash, market wastes comprising of vegetables wastes, fish etc. should be processed through 8 Nos. Bio-Gas Plant of capacity 5 MT each. 4 nos. of which may be installed in 1<sup>st</sup> phase. And another 4 to be installed in 2<sup>nd</sup> phase.
- ▶▶ The organic waste being generated (approximately 4 tons per day) also can be sold to the plantations and other entities interested in organic farming. The value for the organic waste has not been included in the payback analysis as the pricing for the end product is not clear for the surrounding market. However, once started, the project will certainly generate additional revenue from the fertilizer sales.

##### **Packaging and Marketing of Bio-Fertilizer**

The proposed solution for collection of generated biogas from site and transporting it to the prospective buyers are as follows:

The Biogas is to be collected in Steel Bullets that are mounted on trucks and delivered to customers consuming commercial gas.

This alternative will provide the following:

A truck mounted bullet with blower will fill up about 1 ton from the gas balloon.

At start, it is projected that Purulia will sell this gas to three commercial gas consumers. Initially, three bullets (one bullet at each customer site) will be setup. Each of these tanks will have a capacity to store about 1 ton of biogas.

The truck mounted tank will be filled up once every two weeks and a customer's tank will be filled up. The customer is responsible for receiving the gas into their kitchen and any other usage point

The purchaser will be sent a bill on a preset pricing structure.

## 6) DISPOSAL OF MUNICIPAL SOLID WASTES

- ▶ Non-degradable, inert wastes are to be carried daily in the landfill site.
- ▶ After the expiry of life time the landfill site in future will be use for floriculture.
- ▶ Bio-medical Solid wastes should be disposed of in accordance with the bio-medical wastes. (Management & Handling Rules, 1978).

## 7) MANAGEMENT REGULATIONS FOR SOLID WASTE DISPOSAL AND RECYCLING ISSUED BY THE MUNICIPAL LEVEL SOLID WASTE MANAGEMENT COMMITTEE

Management Regulations relating to solid waste disposal and recycling should be adopted by the Purulia Municipal Board after exhaustive discussion with all concerned and the board of councilors meetings in due time.

## 8) ADMINISTRATION

### Institutional Strengthening & Human Resources Development

It is necessary to provide adequate training to all the levels of staff engaged in SWM services. The lower level staff such as sweepers, sanitation supervisors up to the level of Sanitary sub-inspectors should be given training locally in various aspects like storage, segregation of waste and primary collection of waste etc. whereas the sanitary inspectors and above may be given training in modern technologies of waste management, transportation, planning, personnel management programme within and outside the city or state. The senior officers of SWM department should be given adequate training through workshops and visits to various parts of the country and abroad.

### Decentralization of Administration

SWM services can be performed effectively only if its administration is adequately decentralized. The decentralization can be at least 3 tiered- one at the Ward level, second at the Zone level, third at the city level. For creating a competitive environment in regard to performance of SWM systems "Cleanliness Awards" should be given each year to the best performing ward(s).

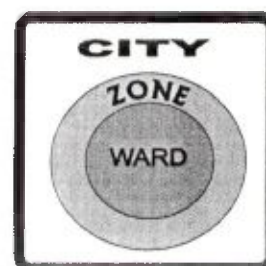



## SW MANAGEMENT SYSTEM AT MUNICIPAL LEVEL

<u>Level</u>	<u>Responsible for</u>
<b>Ward level</b>	Awareness Campaign, Motivation, Collection of waste
<b>Zonal level</b>	Transportation of waste, Training & capacity building of the staff
<b>City level</b>	Processing, disposal & overall management, Research Development & Upgradation

### **a. Ward Level Administration**

The ward level administration should be fully responsible for ensuring storage of segregated waste at source, primary collection of waste, street sweeping and taking the waste to the bulk community waste storage site etc. The cleaning of each street, lane, by lane, markets, etc. should be regularly supervised by the ward level supervisors. Presence of all SWM officers of the Ward in the field during morning hours is most essential. Besides grievance re-dressal system has to be in place in each ward.

### **b. Zonal Administration**

Administrative zones may be made for a group of wards. The zonal administration should effectively supervise and support the work of the ward administration and also provide zonal level support such as construction and upkeep of flooring under the communal waste storage sites transportation of waste from the communal storage sites to the transfer station, processing plant or to the disposal sites as may be determined by the local body. If the zones are not allotted adequate vehicles for the transportation of waste due to paucity of vehicles, the transportation of waste may be coordinated centrally for the optimum utilization of the fleet of vehicles in 2 or 3 shifts.

### **c. City Level Administration**

The city level administration should emphasis on Monitoring of the System Training & capacity building of the staff. It will keep liaison with the zone level administration for periodical review of the operation of the system and take necessary support from it.

The city level administration should supervise and support the zone administration and in cases where the fleet of vehicles is not decentralized at the zone level, the central SWM Department should look after the transportation of waste from the community waste storage sites on a daily basis. The Central SWM Department should be responsible for construction and upkeep of transfer stations, setting up and maintenance of processing plants, incineration plants and vehicles as well as for managing the disposal of waste at the landfill sites in an environmentally acceptable manner. The central level administration should run the operation of the workshop for repairing of solid waste management vehicles and other

accessories. It will also maintain the vehicles like, **Road Sweeping Machine-1, Tractor-1, Ordinary Truck -2** and will deploy those vehicles as and when required at various zones.

The central SWM department should also be responsible for the procurement of vehicles, equipment and land for processing and disposal of waste. As a head office it should take policy decisions and co-ordinate the activities of all the zones and the wards and be answerable to the Chief Executive and elected body for the efficient functioning of the department. It should look after the recruitment of manpower, human resources development, training etc.

**d. Interactive Meets And Communication**

State Governments should organize interactive meets for the subordinate officers in charge of SWM in various local bodies for exchange of information and sharing of experiences.

**9) CREATION OF PLANNING & MONITORING UNIT**

The provision of SWM infrastructure like waste collection, temporary storage, transfer, processing and disposal of waste should be made mandatory pre condition in urban planning.

So there should be a continuous planning and monitoring activity for solid management programme. A planning and monitoring unit **headed by a person having qualification and experience in Public Health Engineering** under the control of **Municipal Engineering Directorate, Department of Municipal Affairs, Govt. of West Bengal** should be created to perform this activity. The planning and monitoring unit should analyze and compare the standards, perform the environmental impact assessment, recommend various level of mechanization and labour involvement needed and feed back the analyzed data to the municipalities as well as Govt. for implementations and / or modification of the system. This unit will also monitor the production and quality control compost manure and also render necessary help for marketing the product for the municipalities. This unit will also monitor the production and quality control of compost manure, render necessary help for marketing the product for the municipalities by creating a common brand name and enhancing brand value through advertisement, establishment of dealers network for all the manures produced in different municipal towns of WB.

# PROPOSED SOLID WASTE MANAGEMENT SYSTEM DIRECTIVES FOR PROPER SURVEILLANCE AND SUSTAINABILITY



## DOMESTIC SOLID WASTE

- ☞ Domestic Solid Waste is to be accumulated in individual premises in two separate containers; Bio-degradable SW in Green container and the non-degradable SW in Yellow container.
- ☞ Collect the two types of domestic SW daily in Wheel Barrow. Each Wheel Barrow should have four containers for bio-degradable and four non-degradable wastes of capacity 20 ltrs.
- ☞ Transfer the waste from Wheel Barrow to transportation vehicles kept at transfer stations. Each transfer station shall have a ramp of suitable height and slope for transferring the waste from Wheel Barrow to standing transportation vehicles directly (see fig given).
- ☞ Transport Bio-degradable SW to Composting Plant by covered vehicle. Transport non-degradable SW to sanitary LandFill Site by covered vehicle.
- ☞ Compost the Bio-degradable SW by the combination of Windrow Method and vermi composting.
- ☞ Dispose off the Residue from Compost Plant to LandFill site.
- ☞ Extract the recyclable materials from non-degradable SW.
- ☞ Dispose the residual non-degradable SW to LandFill site.

## MARKET SOLID WASTE

- ☞ Market Solid Waste (SW) is to be accumulated in bins located at a suitable place convenient for the smooth movement of transportation vehicle.
- ☞ Transport SW to Composting Plant by covered Vehicle as stated above in domestic waste.
- ☞ These markets produce large volumes of solid waste. Depending on the size of the market, the local body shall provide large size containers with lid or skips for the storage of market waste at suitable locations within the market.
- ☞ The shopkeepers shall not dispose of their waste in front of their shop / Establishment or anywhere on the street or open spaces and instead shall deposit their waste as and when generated into the large size container that may be provided for the storage of waste in the market.



- ☞ Compost the Market Waste by Windrow Method.
- ☞ Dispose the Residue from Compost Plant to Land Fill site.

### **WASTE FROM TRADE AND COMMERCE**

- ☞ Waste from trade and commerce in CBD (Central Business District) is to be collected by Wheel Barrow or by Wheel Barrow twice a day at suitable time.
- ☞ Business Houses are to be directed to dispose off their waste either to the door to door collecting vehicles or to the community bins at particular time in a day.
- ☞ Waste from trade and commerce is to be accumulated in Vats located at a suitable places.
- ☞ Transport SW to sanitary LandFill Site by covered Vehicle.
- ☞ Extract the recyclable materials from SW.
- ☞ Dispose the residual of waste to Landfill site.

### **DIRECTIVES TO HOTELS & RESTAURANTS**

All hotels and restaurants may be directed that: -

- ☞ Hostels and restaurants shall refrain from throwing their dry and wet solid waste / sweeping on the footpath, streets, open spaces etc.
- ☞ They shall also refrain from disposal of their waste into the municipal bins. They shall organize their own door step collection system or have this facility through ULB on full cost-recovery basis.
- ☞ They shall store their waste into sturdy metal HDPE / LDPE / Plastic or any other type of container having tight lid and no sharp edges. The container should have appropriate handle and rim at the bottom. The size of each container should not exceed 60 liter for easy handling of waste.

### **DIRECTIVES TO VEGETABLE / FRUIT MARKET SHOP OWNERS**

- ☞ These markets produce large volumes of solid waste. Depending on the size of the market, the local body shall provide large size containers with lid or skips for the storage of market waste at suitable locations within the market.
- ☞ The shopkeepers shall not dispose of their waste in front of their shop / Establishment or anywhere on the street or open spaces and instead shall deposit their waste as and when generated into the large size container that may be provided for the storage of waste in the market.

## **DIRECTIVES TO MEAT AND FISH SHOP OWNERS**

- ☞ The shopkeepers shall not throw any waste in front of their shops or any where on the streets or open spaces.
- ☞ They shall keep sturdy containers (of size not exceeding 60 liters) having lid, handle and rim at the bottom of the container with adequate spare capacity to handle unforeseen loads.

## **DIRECTIVES TO STREET FOOD VENDORS**

- ☞ All street food vendors may be directed not to throw any waste on the street or pavement. They must keep bins for the storage of waste that generate during their activity.

## **DIRECTIVES FOR CONSTRUCTION & DEMOLITION WASTES**

- ☞ No person should be allowed to dispose of construction waste / debris on the streets / open space / foot path or pavement etc.
- ☞ Construction waste shall be stored until removed only within the premises of the building or in containers where such facility to renting out containers is provided by the local body. In exceptional cases such waste may temporarily be stored till a specified date on public or private land with prior written permission of the Govt. or local authority.
- ☞ The local body shall prescribe the rate per M.T on for the collection, transportation and disposal of construction waste / debris and notify the same to the people.
- ☞ Every person who is likely to produce construction waste shall deposit with the local body an approximate amount in advance at the rates as may be prescribed by the local body from time to time for the removal and disposal of construction waste from his premises by the local body.
- ☞ Such amount shall be deposited at the time when the building permission is being sought and in cases where such permission is not required, at any time before such waste is produced.
- ☞ The charges for removal of construction waste to be kept double for those who fail to deposit the amount in advance.
- ☞ Local bodies may make an endeavor to provide the facility of skips / containers on rent for the storage and transportation of construction waste.

## DIRECTIVES FOR INDUSTRIAL WASTES

- ☞ No industry should be allowed to dispose of its waste on the streets / open space or any other place without the permission of local body.
- ☞ Industrial waste shall be stored until removed only within the industry premises.
- ☞ The waste should be stabilized according to the nature of the waste before it is disposed of.
- ☞ Authorized agencies engaged by the industry/industries and approved by the local body shall transport and dispose of the industrial waste at sanitary landfill site of industrial waste as per the prescribed norms and procedure. The rate per MT on for the collection, transportation and disposal of Industrial waste shall be fixed by the mutual agreement between the industries and the authorized agencies for disposal of industrial waste.
- ☞ If the land is provided by the municipality then user charge should be recovered from the industries as well as the Authorized agencies.
- ☞ Local bodies may make an endeavor to provide the facility of skips / containers on rent for the storage and transportation of industrial waste on user charge basis.



Directives to Hospitals / Nursing Homes / Pathological Laboratories / Health Care Centers / Establishments etc.



- ▶ These establishments produce bio-medical as well as ordinary waste.
- ▶ They shall refrain from throwing any bio-medical waste on the streets or open spaces, as well as into the municipal dust bins or the domestic waste collection sites.
- ▶ They shall also refrain from throwing any ordinary solid waste on footpaths, streets or open spaces.
- ▶ They shall keep colour-coded bins or bags as per the directions and guide lines of the Govt. of India, CPCBs & State PCBs for the storage of biomedical waste, amputated limbs, tissues, soiled bandages, used injections, syringes, etc. Another container with a lid for storage of food waste and other waste fit to be disposed of into the municipal domestic waste stream shall be separately provided.
- ▶ The mouth of the polythene bags containing bio-medical waste shall be tied with strong thread and at the end of each day such bags shall be removed from the wards, theatres, dressing room etc. and stored at a safe place in a packed condition for handing over to the municipal authorities for disposal on a daily basis.
- ▶ The instructions of the CPCB / State Pollution Control Boards in regard to Colour Code of bags and source segregation of bio-medical waste etc. shall be strictly followed by all concerned.

## SUGGESTIONS AND RECOMMENDATIONS

- ☞ Standardization of hospital solid waste management system.
- ☞ Collect various types of hospital / clinical waste in four different containers as describe below :
  - For microbiological, surgical, human anatomical organs, tissues, blood and blood fluid, pathological waste, soiled cotton, dressing, animal waste in yellow container.
  - For Disposables, plastic, PVC, polyethylene, sharps (e.g. needles, blades etc), discarded glass in **red** container.
  - For general waste i.e. food waste, kitchen waste, papers, cardboard, in **green** container.
  - For discarded medicine cytotoxic drugs in **black** container.
- ☞ Recommended colour coding for segregation of bio-medical waste at the point of generation and possible disposal options are given below.

### TYPE OF CONTAINERS FOR DISPOSAL OPTIONS OF BIO-MEDICAL WASTE

Colour coding	Type of Container	Waste Category	Treatment options
<b>Yellow</b>	Leak Proof Plastic bag / Disinfected Container	Micro-biological, Surgical, Human Anatomical Organs, Tissues, Blood & Body Fluid, pathological Waste, Solled Cotton, Dressing, Animal Waste	Incineration & MSLF
<b>Red</b>	Puncture Resistance, Impermeable, Rigid, Tamper Resistance	Disposables, plastic, PVC Polythelene, Sharps [e.g. Needle, Blades, etc.] Discarded Glass Wares	i. Autoclaving / Micro-Waving, Shredding, Incineration & MSLF ii. Chemical Treatment & MSLF
<b>Green</b>	Leak Proof Plastic Bag	General Waste i.e. Food Waste, kitchen Waste, papers, card Board	Incineration & or Sanitary Land Filling.
<b>Black</b>	Plastic Bag	Discarded Medicines, Cytotoxic Drugs	To be sent to the Manufacturer

- ☞ Handle and dispose off bio-medical waste as per the norms, prescribed by the Ministry of Environment and Forests under the Environmental Protection Act, 1986 vide Notification No. S. O. 746 (E) dated 16th Oct., 1997.
- ☞ Awareness development among hospital staff, waste handlers, rag pickers and the community as well.
- ☞ Introduction of statutory waste auditing system in all hospitals and disposal sites by environmental engineers both at micro level & macro level.

- ☞ Minimization of hospital waste.
- ☞ Non-degradable item specially PVC plastic should be used as minimum as possible.
- ☞ Location of Treatment & Disposal Site should be as follows.

<b>Sl. No.</b>	<b>Location / Type of Hospital</b>	<b>Site of treatment / Disposal</b>	<b>Authority to whom Responsibility Should be Given for Transportation &amp; Disposal</b>
1.	Very Big Hospitals, where No. of beds >500. Sufficient land is available and is not situated in density populated area.	On-Site	Self (Hospital Authority)
2.	City / Big Urban Area Hospitals (if not as Sl. No. 1)	Off-Site	A consortium of Hospital authorities on commercial basis, Dr. by Municipal Aut.
3.	Urban/Sub-Division Town Hospital	Off-Site	Private Participation under the guidance of Local Municipal Authority
4.	Rural Hospitals	On-Site	Self (Hospital Authority)



## WHAT SHOULD NOT BE DONE



- ☞ Throwing of waste on the street
- ☞ Open waste storage in road side vats or in other unhygienic street bins
- ☞ Allow waste handlers without hand gloves and masks and shoes
- ☞ Transport waste into uncovered van
- ☞ Allow waste to touch ground in between collection and transportation
- ☞ Multiple handling of waste in the matter of collection, transportation and disposal of waste
- ☞ Use of unproven technologies
- ☞ Mix up construction debris into general waste
- ☞ Mix up hospital waste/ clinical waste (bio-medical waste) with general waste

## WHAT SHOULD BE DONE



- ☞ Impose fine on throwing waste on the street
- ☞ Storage of waste at source
- ☞ Door step collection of waste
- ☞ Sweeping of streets on all working days of the year
- ☞ Impose work norms sweeping of street
- ☞ Conservancy workers should be engaged for 8 working hours a day; at least 6 hours a day
- ☞ Provide litter bins at public places
- ☞ Transportation of waste to synchronize with waste storage facility – dispense with manual loading of waste
- ☞ Before dumping the SW in landfill site the bottom of the site should be covered with a thin polythene sheet
- ☞ To increase the capacity of dumping the land-fill site may be excavated up to the depth above the permanent ground water table
- ☞ Create awareness about the hazards associated with solid waste
- ☞ Encourage N.G.O.s to take part in solid waste management system
- ☞ Encourage private sector participation in waste management
- ☞ Increase public participation in primary collection of waste
- ☞ Transport waste on day to day basis in closed body vehicle
- ☞ Dispose of waste in an environmentally accepted manner through establishment of sanitary landfill site
- ☞ Introduce element of cost recovery
- ☞ Creation of public grievances redressal mechanism
- ☞ Enforce sanitation laws and rules
- ☞ Create heavy a forestation surrounding the landfill site
- ☞ Conversion of Organic / Biodegradable Waste into Bio Organic fertilizer (compost)
- ☞ Create management information system for solid waste
- ☞ Enactment of a public cleansing law and empowering the local bodies for its effective implementation
- ☞ Appropriate design for community containers, primary collection and transport vehicles, transfer locations and disposal facilities
- ☞ To evaluate better management and optimum utilization of man and materials



## **Various Forms Of Public Private Participation In Solid Waste Management System**

1. Engagement of local BPL persons or NGOs for door to door collection of solid waste.

(Implements for collections may be supplied by the municipalities and the collectors may be allowed to collect Rs.20/- to 30/- per month per APL family and Rs. 10/- to 12/- from BPL families, for house to house collection of waste.)

2. Engagement of private agencies for transportation of solid waste from transfer station to disposal sites.

(The private agency may be made responsible for transportation of total waste of the town to dumping ground on yearly contact basis. The total cost of vehicles and machineries and other necessary arrangement of transportation of waste and O & M cost should be borne by the private agency. It is advisable that the agreement with the private agency may be made for transportation of the total waste generated in the town as lump-sum contact basis irrespective of no. of trips or quantity of waste transported.)

3. Engagement of private agencies for solid waste processing

(The private agency may be made responsible for processing of bio-degradable waste in to manure The private agency would sell the manure produced from the waste and will pay a royalty to the municipality on yearly contact basis. The total cost of plant machineries and other necessary arrangement of processing unit of the waste and O & M cost should be borne by the private agency. The municipality will only send the waste to site and provide the land for compost plant.)

4. Engagement of private agencies for solid waste processing and disposal.

(The private agency would be responsible for processing of degradable waste in to manure and sanitary disposal of non-degradable waste brought at site. The private agency would sell the manure produced from the waste and will pay a royalty to the municipality on yearly contact basis. The total cost of plant & machineries and other necessary arrangement of processing unit of the waste and O & M should be borne by the private agency. The municipality will provide only the land.)

5. Engagement of private agencies for total solid waste management systems i.e collection, transportation, processing and disposal of waste.

(The private agency may be made responsible for the entire process of SWM system i.e. collection-transportation-processing of degradable waste in to manure and sanitary disposal of non-degradable waste of the town. The private agency would sell the manure produced from the waste and will pay a royalty to the municipality on yearly contact basis. The total cost of plant & machineries and other necessary arrangement of processing unit of the waste and O & M cost should be borne by the private agency. The municipality will provide only the land.)

*Municipal Authority may go for Public Private Participation {PPP} in any or combination of two or more forms of PPP stated above. Detailed terms & conditions of PPP may be worked out on the merit of specific case.*



## Time Schedule for SWM Project : Purulia Municipality

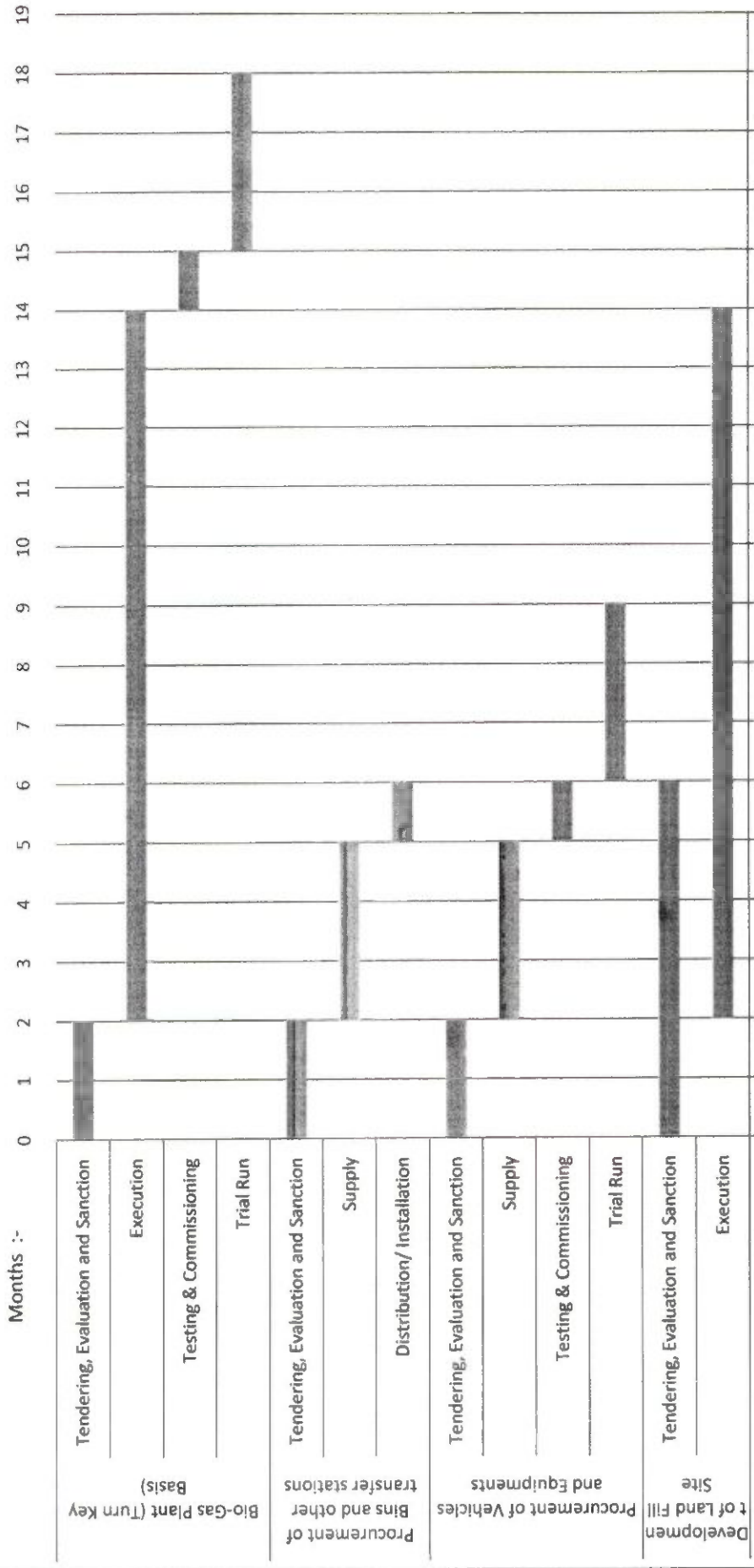

# **ENVIRONMENTAL IMPACT ASSESSMENT**

## **1.0 INTRODUCTION**

The Municipal Engineering Directorate of West Bengal has proposed development of Municipal Solid Waste (MSW) processing complex at Purulia, West Bengal for managing and processing the solid waste generated by the municipality.

The proposed project would involve segregation of the solid waste to biodegradable and different sets of non-biodegradable components. This will be followed by recycling the non-biodegradable components and converting the biodegradable parts to biogas and organic fertilizers.

The proposed facility is proposed at a site located 9 km from Purulia town spread over 10 acres. The proposed plant at Purulia dumpsite will be designed to process 77 TPD (Tons per Day) of MSW. The solid waste of Purulia Municipality is proposed to be disposed of partly by processing and partly by sanitary landfill method. Bio-degradable part will be processed bio gas will be generated.

The proposed project falls under Item 7 (i) (Common Municipal Solid Waste Management Facilities) as per Environmental Impact Assessment Notification dated September 14, 2006.

The purpose of this Environmental Impact Assessment (EIA) study is to provide information on the nature and extent of environmental impacts arising from the construction and operation of the proposed project.

The solid waste at project site shall be provided by Purulia Municipality. The proposed integrated waste processing facility will have a section for processing Municipal Solid Waste (MSW) which will involve manual segregation to separate both recyclables and biodegradables, thus produced will be utilized for the generation of biogas.

## **2.0 SALIENT FEATURES OF PROJECT**

The Salient features of the project are provided below:

- Total Project Cost: Rs.14.60 Crores
- Land area: 0.6 Acres(for Biogas Facility).  
In total 3.0 Acres (including Landfill Operation)
- MSW processing capacity 40 TPD

### **3.0 SITE LOCATION**

At Mouza - Chharra, approximately 15 Km away from the city center of Purulia town.

### **4.0 PROJECT UTILITIES/AMENITIES**

The proposed integrated waste management facility will have a capacity to process 40 TPD of MSW to generate about 4000KWH of Electric energy and 4 MT of organic manure per day.

#### **Water**

The Water Requirement for the Biogas Plant Facility will be fulfilled from a DTW. Since the facility do not have any discharge, so it will have minimal impact on the water body.

The Electricity requirement will be fulfilled primarily by the town authority. But after commissioning of the project, the biogas facility will generate electricity from the biogas produced and will not require any external supply and will be operating self sufficiently.

### **5.0 ENVIRONMENTAL SETTING OF THE STUDY AREA**

The baseline environmental status was assessed based on primary and secondary data collected through on-site field observations and obtained from other regulatory agencies. The following environmental components were focused at during this study:

Air Environment (Meteorology, Ambient Air Quality, Noise Levels, Traffic Pattern, etc.)

Water Environment (Quality and Quantity of Surface and Groundwater sources)

Land Environment (Geology, Hydrogeology, Landuse, Solid Waste generation and characteristics)

Ecological Environment (Terrestrial and Aquatic Flora & Fauna)

Socio-Economic Environment (Demographic profile, Occupational structure, Educational status, Literacy status, etc.)

The baseline status collated from analysis of secondary and primary data is summarized in the Table E-1 below.



**Table E-1: BASELINE ENVIRONMENTAL STATUS**

Attribute	Baseline status																																						
Meteorology	Purulia is one of the drought prone districts of West Bengal. It has a sub tropical climate nature and is characterized by high evaporation and low precipitation. Temperature is very high in summer and low in winter which varies from 2.8 degrees in winter to 52 degrees in summer thus causes dryness in moisture. Record highest temperature is 54 degrees in 2011, which is the second highest temperature ever recorded in Asia, following Jacobabad's record 55.7 degrees. Rainfall defines the climate of the district. South west monsoon is the principal source of rainfall in the district. Average annual rainfall varies between 1100 and 1500 mm. The relative humidity is high in monsoon season, being 75% to 85%. But in hot summer it comes down to 25% to 35%																																						
Ambient Air Quality	The air quality of the municipality area is similar to other urban centers of the Purulia district. The overall air quality observed in NO <sub>2</sub> : 22.17 Microgram per meter cube PM 10: 108.37 Microgram per meter cube SO <sub>2</sub> : 2.00 Microgram per meter cube.																																						
Water Quality	<p>The following table is a fair representation of long term water quality of the Purulia Surface water samples on analysis and comparison with CPCB class "C" water showed that DO of the samples is good and ranges from 5.9 to 6.9 whereas BOD is high in comparison to maximum 3 mg/l. Surface water samples also showed the presence of total Coliform and faecal Coliform indicating organic contamination.</p> <table border="1" data-bbox="523 1249 1353 1899"> <thead> <tr> <th data-bbox="523 1249 911 1339" rowspan="2">Chemical</th> <th colspan="2" data-bbox="911 1249 1353 1294">Acceptable limit (in mg/L or ppm)</th> </tr> <tr> <th data-bbox="911 1294 1098 1339">WHO</th> <th data-bbox="1098 1294 1353 1339">BIS</th> </tr> </thead> <tbody> <tr> <td data-bbox="523 1339 911 1384">Arsenic (As)</td> <td data-bbox="911 1339 1098 1384">0.01</td> <td data-bbox="1098 1339 1353 1384">0.01/0.05*</td> </tr> <tr> <td data-bbox="523 1384 911 1429">Fluoride (F<sup>-</sup>)</td> <td data-bbox="911 1384 1098 1429">1.5</td> <td data-bbox="1098 1384 1353 1429">1.0/1.5*</td> </tr> <tr> <td data-bbox="523 1429 911 1473">Chloride (Cl<sup>-</sup>)</td> <td data-bbox="911 1429 1098 1473">*</td> <td data-bbox="1098 1429 1353 1473">250/1000*</td> </tr> <tr> <td data-bbox="523 1473 911 1552">Residual Chlorine (Res. Cl<sub>2</sub>) (used for disinfection)</td> <td data-bbox="911 1473 1098 1552">0.2</td> <td data-bbox="1098 1473 1353 1552">0.2/1.0*</td> </tr> <tr> <td data-bbox="523 1552 911 1597">Iron (Fe)</td> <td data-bbox="911 1552 1098 1597">*</td> <td data-bbox="1098 1552 1353 1597">0.3</td> </tr> <tr> <td data-bbox="523 1597 911 1641">Phosphate (PO<sub>4</sub><sup>3-</sup>)</td> <td data-bbox="911 1597 1098 1641">*</td> <td data-bbox="1098 1597 1353 1641">5</td> </tr> <tr> <td data-bbox="523 1641 911 1686">Nitrate (NO<sub>3</sub><sup>-</sup>)</td> <td data-bbox="911 1641 1098 1686">50</td> <td data-bbox="1098 1641 1353 1686">45</td> </tr> <tr> <td data-bbox="523 1686 911 1731">Nitrite (NO<sub>2</sub><sup>-</sup>)</td> <td data-bbox="911 1686 1098 1731">3</td> <td data-bbox="1098 1686 1353 1731">3</td> </tr> <tr> <td data-bbox="523 1731 911 1776">Ammonium (NH<sub>4</sub><sup>+</sup>)</td> <td data-bbox="911 1731 1098 1776">*</td> <td data-bbox="1098 1731 1353 1776">5</td> </tr> <tr> <td data-bbox="523 1776 911 1854">Total Alkalinity (in terms of CaCO<sub>3</sub>)</td> <td data-bbox="911 1776 1098 1854">-</td> <td data-bbox="1098 1776 1353 1854">200/600*</td> </tr> <tr> <td data-bbox="523 1854 911 1899">pH</td> <td data-bbox="911 1854 1098 1899">-</td> <td data-bbox="1098 1854 1353 1899">6.5-8.5</td> </tr> </tbody> </table> <p data-bbox="523 1910 1353 1980">*Not of health concern at levels found in drinking-water. *Permissible limit in absence of alternate source.</p>	Chemical	Acceptable limit (in mg/L or ppm)		WHO	BIS	Arsenic (As)	0.01	0.01/0.05*	Fluoride (F <sup>-</sup> )	1.5	1.0/1.5*	Chloride (Cl <sup>-</sup> )	*	250/1000*	Residual Chlorine (Res. Cl <sub>2</sub> ) (used for disinfection)	0.2	0.2/1.0*	Iron (Fe)	*	0.3	Phosphate (PO <sub>4</sub> <sup>3-</sup> )	*	5	Nitrate (NO <sub>3</sub> <sup>-</sup> )	50	45	Nitrite (NO <sub>2</sub> <sup>-</sup> )	3	3	Ammonium (NH <sub>4</sub> <sup>+</sup> )	*	5	Total Alkalinity (in terms of CaCO <sub>3</sub> )	-	200/600*	pH	-	6.5-8.5
Chemical	Acceptable limit (in mg/L or ppm)																																						
	WHO	BIS																																					
Arsenic (As)	0.01	0.01/0.05*																																					
Fluoride (F <sup>-</sup> )	1.5	1.0/1.5*																																					
Chloride (Cl <sup>-</sup> )	*	250/1000*																																					
Residual Chlorine (Res. Cl <sub>2</sub> ) (used for disinfection)	0.2	0.2/1.0*																																					
Iron (Fe)	*	0.3																																					
Phosphate (PO <sub>4</sub> <sup>3-</sup> )	*	5																																					
Nitrate (NO <sub>3</sub> <sup>-</sup> )	50	45																																					
Nitrite (NO <sub>2</sub> <sup>-</sup> )	3	3																																					
Ammonium (NH <sub>4</sub> <sup>+</sup> )	*	5																																					
Total Alkalinity (in terms of CaCO <sub>3</sub> )	-	200/600*																																					
pH	-	6.5-8.5																																					

Ground water Availability	The project site is comprised of thick alluvial soil. However, Fluoride contamination of the groundwater is prevalent in some ground water wells in the region.
Soil Quality	Due to undulated topography nearly 50% of the rainfall flows away as runoff. The district is covered by mostly residual soil formed by weathering of bed rocks.
Biological Environment	The City is adjacent to the River Kangshabati with typical flora Fauna applicable for the region. No protected or reserve forest falls within 10 km radius of the proposed project site. Water bodies such as River Kangshabati is the main water body of the area flowing within 12 km from the proposed project site. The project site does not come within an existing or proposed ecological sensitive zone. No threatened or endangered plant or animal species are known to exist in and around the site.
Socio-economy	The Purulia Municipality has population of 124436 of which 62351 are males while 58716 are females as per report released by Census India 2011.  Population of Children with age of 0-6 is 12653 which is 10.45 % of total population of Purulia (M). In Purulia Municipality, Female Sex Ratio is of 942 against state average of 950. Moreover Child Sex Ratio in Purulia is around 945 compared to West Bengal state average of 956. Literacy rate of Purulia city is 82.09 % higher than state average of 76.26 %. In Purulia, Male literacy is around 88.40 % while female literacy rate is 75.39 %.

## 6.0 ENVIRONMENTAL IMPACT ASSESSMENT & ENVIRONMENTAL MANAGEMENT PLAN

Environmental impact due to the construction and operation stages of the project was predicted quantitatively. Impacts were also evaluated qualitatively using engineering judgment and best management practices.

Adequate environmental management measures will be incorporated during the entire planning, construction and operation stages of the project to minimize the adverse environmental impacts and assure sustainable development of the area.

The impacts during the construction phase will be temporary in nature. This summary details the pollution sources and mitigation measures proposed for the project.

### 6.1 AIR ENVIRONMENT

During the construction phase, operation of construction equipments and vehicles will be the main sources of pollution. A dust control plan will be implemented and regular maintenance of vehicles and equipment will be carried out.

During the operation phase, the main sources of pollution shall be odor emissions from waste handling and processing and emissions due to vehicular movement. Adequate mitigation measures shall be implemented.

## **6.2 NOISE ENVIRONMENT**

During the construction phase, adequate mitigative measures such as controlled time of construction, job rotation etc. will be implemented.

During the operation phase, the sources of noise emissions shall be equipments such as shredders, generator etc and vehicular movement. Noise enclosures shall be provided wherever possible and workers shall be provided with ear plugs.

## **6.3 WATER ENVIRONMENT**

The leftover sludge from the Biogas Plant will be directed to Sludge tanks specially designed to rest and convert the unprocessed organic waste to organic manure.

## **6.4 LAND ENVIRONMENT**

During operation phase of the project, the recyclables from waste segregation system will be sold to suitable agencies. The organic waste shall be processed to Biogas and organic manures and sold to prospective customers. The remaining part of the MSW which can neither be processed nor sold as recyclables will be sent to the landfill facility.

## **6.5 ECOLOGICAL ENVIRONMENT**

There is no ecologically sensitive area within a 10 km radial distance of the project site. No wildlife sanctuary or national park is present within the study area. A peripheral greenbelt will be provided.

## **6.6 SOCIO ECONOMIC ENVIRONMENT**

The proposed project will lead to employment generation and will have a positive impact on the socio economic environment. Preference to local population shall be given and adequate mitigation measures will be ensured to reduce odor emissions and disease vectors from proposed site.



## 7.0 ENVIRONMENTAL MANAGEMENT SYSTEM

For the effective implementation of the EMP, an Environmental Management System (EMS) will be established at the proposed project. The EMS will include the following:

1. An Environmental Management cell
2. Environmental Monitoring Program
3. Personnel Training
4. Regular Environmental Audits and Corrective Action
5. Documentation – Standard operating procedures Environmental Management Plans and other records.

### **Environmental Monitoring**

Solid waste sites are prone to causing environmental degradation of all the possible elements including water, air, soil, groundwater besides spreading disease vectors like fly, mosquitos, and pigs. Setting up facilities like these needs to focus on minimizing the environmental impact on the area so that the eco system and the human residents do not have any impact on the living conditions. Therefore a careful monitoring protocol needs to be set up with the minimum of the following components embedded:

1. Regular (monthly) testing of water quality in the adjacent water bodies
2. Regular (weekly) testing of water samples leaving the site
3. Random (one a quarter) testing of the solid waste for presence of toxins
4. Continuous air quality measurement
5. Once a year testing of the groundwater quality
6. Monitor any fire causing activities in the area.

The parameters to be tested in surface water are:

- BOD
- COD
- pH
- Ammonia
- Phosphorus
- Cyanides
- Sulfur

The parameters to be tested in the groundwater are:

- Nitrates
- Nitrites
- pH
- COD
- Dioxins

The parameters to be tested in air are:

- Pm10
- SO<sub>x</sub>

- NOx
- CO

The parameters to be tested in the random solid waste sampling are:

- BTEX (Benzene, Toluene, Ethyle-benzene and Toluene)
- Pesticides
- Toxicity

The data collected should be carefully maintained and any trend should be investigated. Any abnormal data should be investigated and cause mitigated.

## **8.0 CONCLUSION**

All possible environment aspects have been adequately assessed and necessary control measures have been formulated to meet statutory requirements. Thus implementing this project will not have any appreciable negative impacts. Moreover, the landfill area requirement at Purulia and other landfill sites will progressively reduce significantly as the solid waste will be converted to stable form (inert) before being sent for disposal at landfill site. This would save upon the future requirements of area for land filling. Energy generation through Biogas would be an added advantage.

**NOTES:**

- 1) ALL DIMENSIONS ARE IN mm UNLESS OTHERWISE NOTED.
- 2) THE DIMENSION CAN CHANGE BASED ON THE DESIGN CONSIDERATIONS AND SITE CONDITIONS.

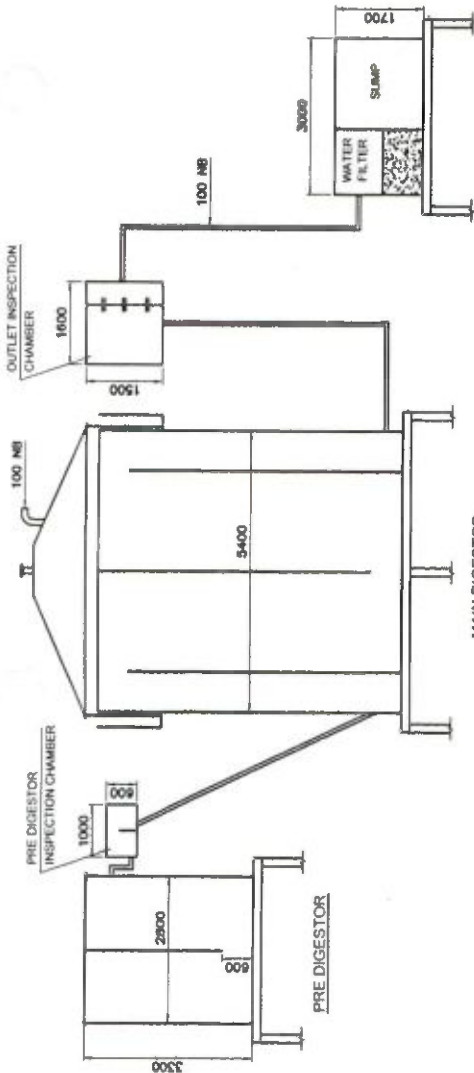

**MAIN DIGESTOR**

**ELEVATION**

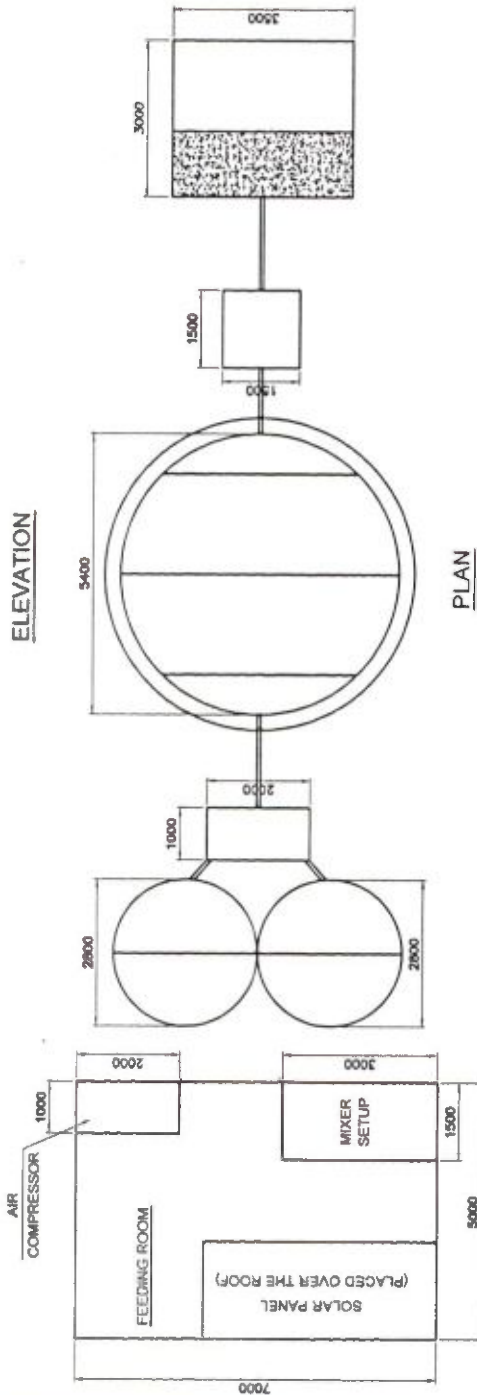

**PLAN**



**BALLOON ROOM**

<b>MUNICIPAL ENGINEERING DIRECTORATE</b>			
PROJECT: SANTIPUR MUNICIPALITY			
TITLE: GENERAL ARRANGEMENT OF BIO GAS PLANT			
DRN	N.P.H.	DATE	DRG. NO.:-
CHKD	V.B.L.	09/08/16	MED/BGP/01
APP	P.N.M.		
			REV. NO. 0



**MATERIAL SPECIFICATION**

SHELL, BOTTOM, ROOF ETC.	IS : 2062 GR A
STRUCTURAL STEEL	IS : 2062
NOZZLE PIPES	IS : 1239, HY7 / IS : 3569
NOZZLE FLANGES	IS : 2062 GR A
GASKETS	CAF
PIPE FITTINGS	A 234 WPB / A 105
BOLTS & NUTS	IS 1367 CL. 4.6/4.0

**NOTES:**

- 1) ALL DIMENSIONS ARE IN mm UNLESS OTHERWISE NOTED.
- 2) ALL NOZZLES BOLT HOLES TO STRADDLE THEIR PRINCIPLE  $\phi$ .
- 3) ALL FILLET WELDS SHALL BE 6mm THK. CONTINUOUS FILLET U.G.O.
- 4) PROVIDED 6# TELL TALE HOLE IN ALL REIN PAD PLATES ON HORIZONTAL  $\phi$ .
- 5) CHIP BACK WELD JOINT TO SOUND METAL BEFORE STARTING WELD ON OTHERSIDE.
- 6) ALL ELEVATION ARE FROM BOTTOM OF BOTTOM PLATE.
- 7) TANK EXTERNAL SURFACE - SURFACE CLEAN BY MANUAL WIRE BRUSH WITH 1 COAT OF ZINC PHOSPHATE PRIMER (SYNTHETIC BASE) FOLLOWED BY 2 COATS OF SYNTHETIC ENAMEL PAINT.
- 8) DOME THICKNESS & SUPPORTING STRUCTURE TO BE DETERMINED AS PER DESIGN CALCULATION.
- 9) SIZE OF TROUGH AS PER DESIGN CALCULATION.

**NOZZLE SCHEDULE**

DESIGN CODE	IS : 803
DESIGN PRESSURE	ATM
DESIGN TEMP.	AMB
WORKING PRESSURE	ATM
WORKING TEMP.	AMB
HYDROSTATIC TEST PRESSURE	FULL OF WATER
CONTENTS	---
SP. GRAVITY	---
RADIOGRAPHY	NIL
JOINT EFFICIENCY	0.7
CORROSION ALLOWANCE	1.5 (1.0 FOR ROOF)
INSULATION	---
EMPTY WEIGHT	---
WEIGHT WITH FULL OF WATER	---
WEIGHT WITH FULL OF PRODUCT	---
CAPACITY	135 M <sup>3</sup>

**NOZZLE SCHEDULE**

NOZZ.	SERVICE	SIZE NB	SCH.	QTY.	FLANGE STD.	TYPE	CLASS	PROJ.	REMARK
N1	INLET	80	HY7	01	B16.5	SORF	150#	150	
N2	OUTLET	80	HY7	01	B16.5	SORF	150#	150	
N3	DRAIN	80	HY7	01	B16.5	SORF	150#	150	
N4	GAS OUTLET	50	HY7	01	B16.5	SORF	150#	150	
M1	SHELL MANHOLE	600	5 THK	01	AS PER STD			150	
M2A/B	ROOF MANHOLE	600	5 THK	01	AS PER STD			150	

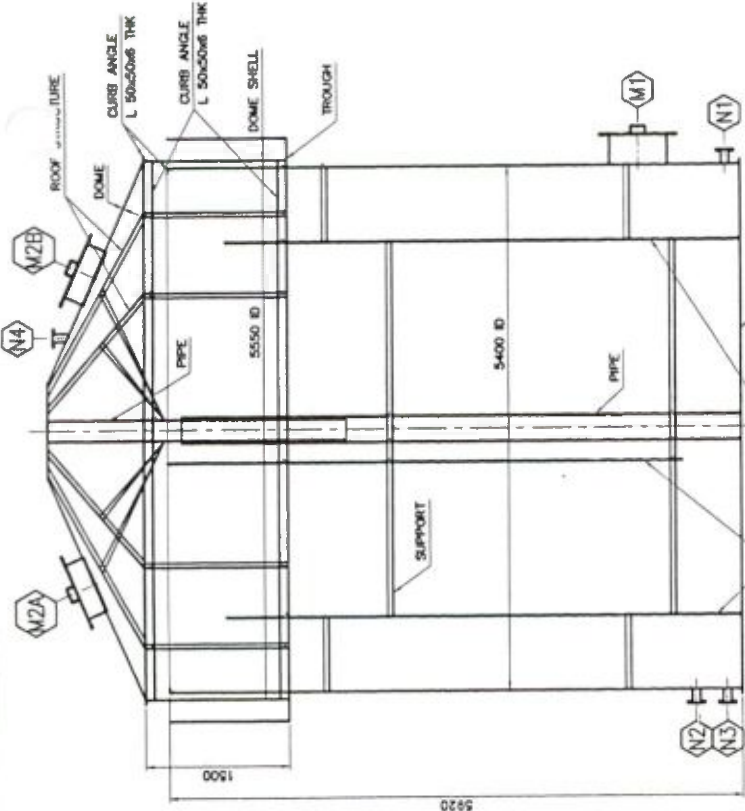

**ELEVATION**

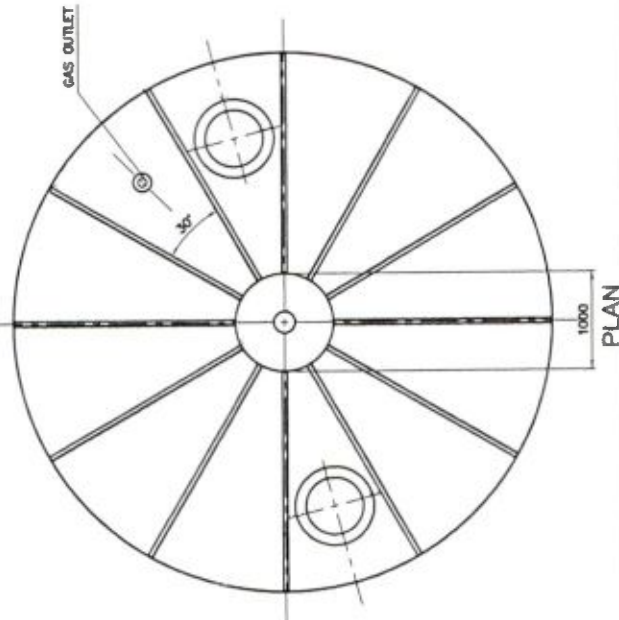

**PLAN**

**MUNICIPAL ENGINEERING DIRECTORATE**

PROJECT	SANTIPUR MUNICIPALITY	QTY.	01 NO
TITLE	GENERAL ARRANGEMENT OF MAIN DIGESTOR	REV. NO.	0
DRN	N.P.H.	DATE	DRG. NO. :-
CHKD	V.B.T.	09/08/16	MED/MD/01
APP	P.A.M.		

**MATERIAL SPECIFICATION**

SHELL, BOTTOM, ROOF ETC. IS : 2062 GR A  
 STRUCTURAL STEEL IS : 2062  
 NOZZLE PIPES IS : 1239, HYY  
 NOZZLE FLANGES IS : 2062 GR A  
 GASKETS CAF  
 PIPE FITTINGS A 234 WPB / A 105  
 BOLTS & NUTS IS 1367 CL. 4.6/4.0

**NOTES:**

- 1) ALL DIMENSIONS ARE IN mm UNLESS OTHERWISE NOTED.
- 2) ALL NOZZLES BOLT HOLES TO STRADDLE THEIR PRINCIPLE C.
- 3) ALL FILLET WELDS SHALL BE 6mm THK CONTINUOUS FILLET UNO.
- 4) PROVIDED 6# TELL TALE HOLE IN ALL REIN PAD PLATES ON HORIZONTAL CENTER LINE.
- 5) CHIP BACK WELD JOINT TO SOUND METAL BEFORE STARTING WELD ON OTHERSIDE.
- 6) ALL ELEVATION ARE FROM BOTTOM OF BOTTOM PLATE.
- 7) TANK EXTERNAL SURFACE - SURFACE CLEAN BY MANUAL WIRE BRUSH WITH 1 COAT OF ZINC PHOSPHATE PRIMER (SYNTHETIC BASE) FOLLOWED BY 2 COATS OF SYNTHETIC ENAMEL PAINT.

**NOZZLE SCHEDULE**

DESIGN CODE	IS : 803
DESIGN PRESSURE	ATM
DESIGN TEMP.	AMB
WORKING PRESSURE	ATM
WORKING TEMP.	AMB
HYDROSTATIC TEST PRESSURE	FULL OF WATER
CONTENTS	--
SP. GRAVITY	--
RADIOGRAPHY	NIL
JOINT EFFICIENCY	0.7
CORROSION ALLOWANCE	1.5 (1.0 FOR ROOF)
INSULATION	--
EMPTY WEIGHT	--
WEIGHT (FULL OF WATER)	--
WEIGHT WITH FULL OF PRODUCT	--
CAPACITY	20 M <sup>3</sup>

**NOZZLE SCHEDULE**

NOZZ.	SERVICE	SIZE NB	SCH.	QTY.	STD.	FLANGE TYPE/CLASS	PROJ.	REMARK
N1	INLET	80	HYY	01	B16.5	SORF 150#	150	
N2	OUTLET	80	HYY	01	B16.5	SORF 150#	150	
N3	VENT	80	HYY	01	B16.5	SORF 150#	150	
N4	DRAIN	50	HYY	01	B16.5	SORF 150#	150	
M1	MANHOLE	600	5 THK	01		AS PER STD.	150	

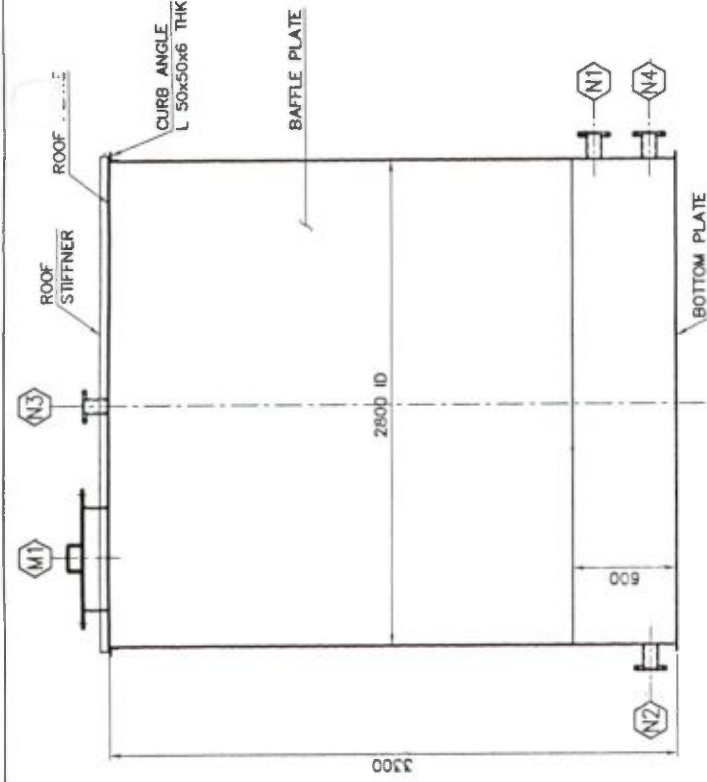

**ELEVATION**

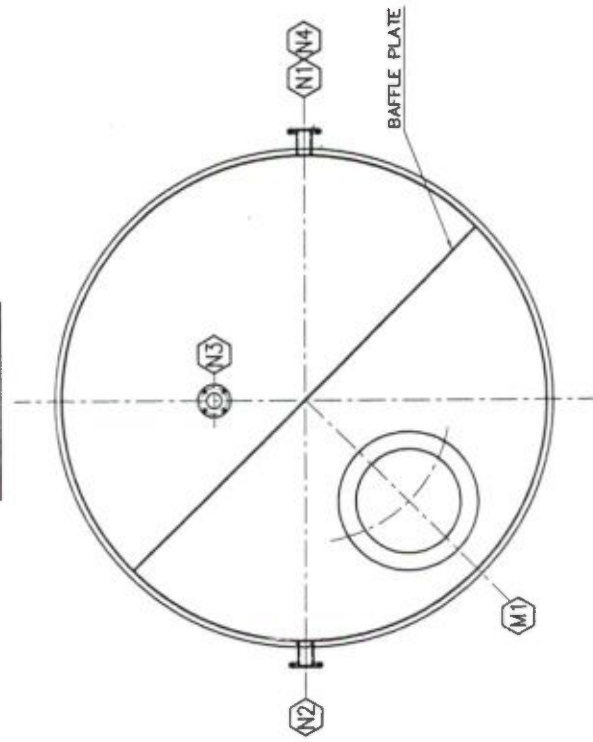

**PLAN**

**MUNICIPAL ENGINEERING DIRECTORATE**

PROJECT	SANTIPUR MUNICIPALITY	QTY.	02 NOS
TITLE	GENERAL ARRANGEMENT OF PRE DIGESTOR		
DRN.	N.P.H.	DATE	DRG. NO. :-
CHKD	V.B.T.	09/08/16	MED/PO/01
APP	P.N.M.		
			REV. NO.
			0



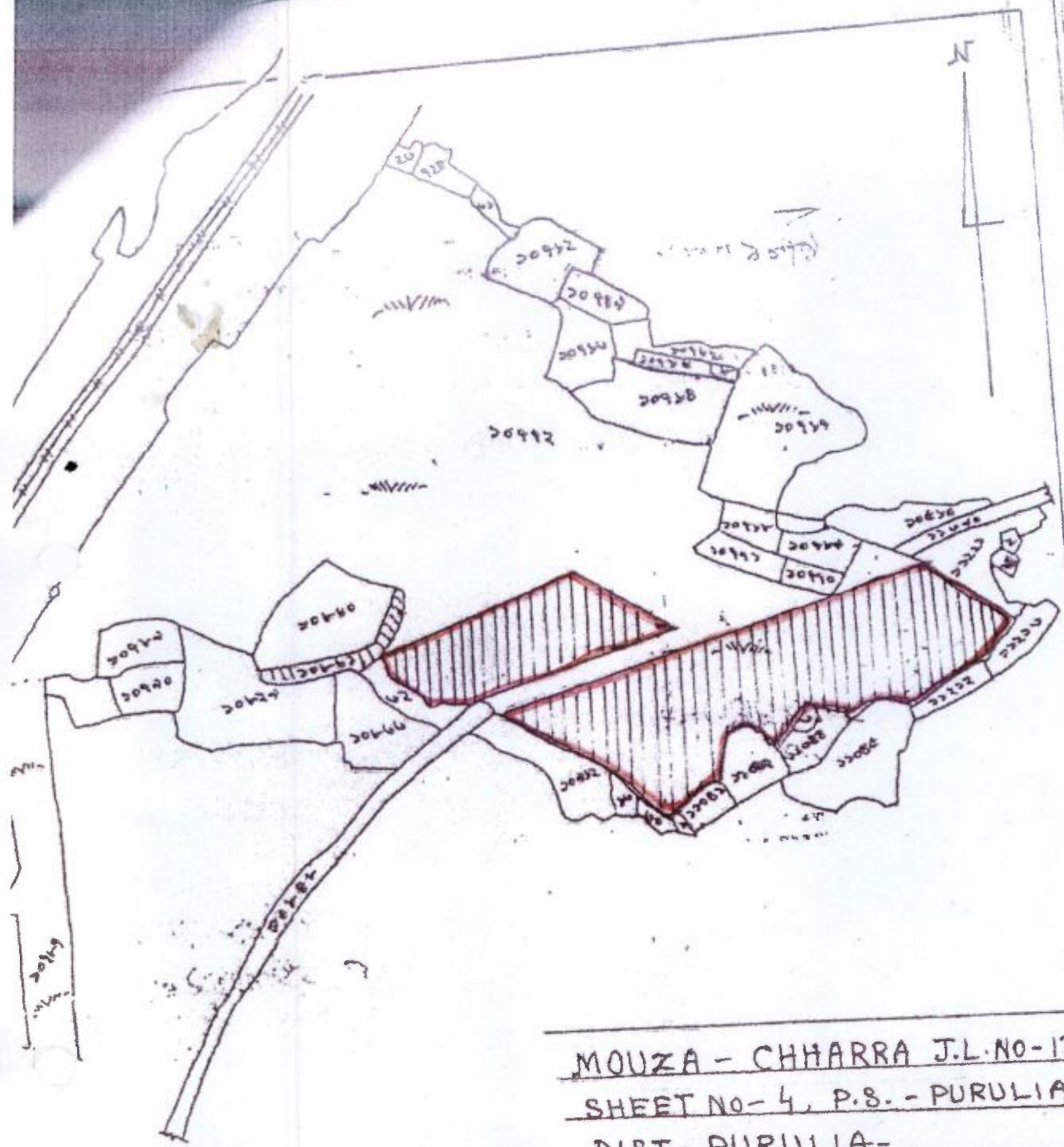

MOUZA - CHHARRA J.L. NO-131  
SHEET NO-4, P.S. - PURULIA  
DIST - PURULIA -  
R.S. PLOT NO- 10772  
AREA: 10.00 Acres

Proposed for Dumping ground  
 shown in RED  for Purulia Municipality

Countersigned  
 D. K. Ghosh  
 BLOCK LAND & LAND REFORMS  
 OFFICER, PURULIA

  
 Shamim Dad Khan  
 Chairman  
 Purulia Municipality

TRACED BY  
 Kalirabhan Char  
 Amin



65

## APPRAISAL REPORT

1.	Name of the Project	Solid Waste Management Project under Purulia Municipality		
2.	Sectoral area	Urban		
3.	Total Financial outlay	1459.54 Lakh		
4.	Financial arrangement			
<i>Funds being made available by</i>				
	<i>Implementing agency</i>	<i>Gol Share</i>	<i>State Share</i>	<i>Others, if any(ULB share &amp; Addl. State share)</i>
	Purulia Municipality	510.84 Lakh	170.28 Lakh	778.42 Lakh
				1459.54 lakh
5.	Project duration (dates/months/years)	24 Months		
6.	Location of project	Purulia Municipality in Purulia District, West Bengal		
7.	Previous phases, if any	No		
8.	Statutory required	Clearance/Permission from concerned authority such as State Environment Department, State Electricity Board, State Pollution Control Board (SPCB), Highways, PWD etc. (wherever applicable).		
9.	Statutory obtained	To be obtained after approval of the project by the ULB.		
10.	Details of Feasibility Studies done (if any)	The project is technically and financially feasible		
11.	Implementing agency	Purulia Municipality with technical assistance from MED, Govt. of West Bengal		
12.	Basic design of the project			
i)	Goals and Objectives	The main objective is conversion of waste to energy (Electricity) through generation of bio-gas, preparation of manure and proper management of recyclables.		
ii)	Activities involved	Collection, transportation, separation and production of Electricity through bio-gas, manure and selling of recyclables, sanitary land filling for inert as per relevant manuals and guidelines of Govt. of India.		
iii)	Outputs of the project	Waste free city with minimum discharge to landfills.		
iv)	Outcome of the project	The day to day hazards of waste mechanism will be addressed with due importance to socio-economic view points, as well the municipal revenue infrastructure will be soundly built in a new form.		
13.	Target population			
i)	As per Census 2011	121436		
ii)	Base Year (2019)	133336		
iii)	Intermediate Year (2029)	147580		
iv)	Final Year (2039)	161247		
14.	Per capita expenditure proposed			
i)	Considering Census population 2011	Rs. 1202.00		
ii)	Considering Base Year population (2019)	Rs. 1094.63		
15.	Quantitative and qualitative (verifiable) target Indicators	As per CPHEEO Manual published by MoUD, Govt. of India		

16.	Environmental sustainability of the project	The project does not affect the green belt. No tree is required to be cut. No water body is affected by the proposed project. No natural outlays are also affected by the proposed project. There is no possibility of soil erosion.
17.	Land acquisition / Resettlement and Rehabilitation involved	Land already procured
18.	Operation and Maintenance	Purulia Municipality
19.	Finance Plus Criteria	
(i)	Innovations and piloting of new approaches	Waste to energy (Electricity)
(ii)	Innovations in financing and leveraging	Surplus income will be generated after meeting Operation and Maintenance costs.
20.	Whether the project is recommended for Sanction or not (Y/N).	Yes
	If not, please mention reasons and area for improving DPR.	Not Applicable
22.	Estimated cost for consideration & approval (INR Lakh)	<b>Rs. 1459.54 Lakh</b>

  
 Chief Engineer  
 Municipal Engineering Directorate  
 Govt. of West Bengal



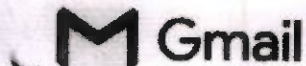

Director, SUDA &lt;sbm.wbsuda@gmail.com&gt;

## Kind release of fund for 2nd Installment for already sanctioned 10 Nos of SWM projects

4 messages

63

Director, SUDA &lt;sbm.wbsuda@gmail.com&gt;

Wed, Jun 13, 2018 at 12:04 PM

To: mkmandalud@gmail.com, Rajendar Jayal &lt;rajjhuni@gmail.com&gt;

Cc: vk.jindal@nic.in, sanghamitrab@kpmg.com, "Dewan, Salim" &lt;salimdewan@kpmg.com&gt;

Bcc: Sujay Mitra &lt;sujay.mitra@gmail.com&gt;, bkp.al.suda@gmail.com, BADRI NARAYAN Kar &lt;karbnarayan@gmail.com&gt;

Ref: Letter No. 1/31/2015-SBM dated 12th June, 2018

Sir,

Reference above, we are thanking you for releasing fund for 1st Installment of new 13 SWM Projects for 13 ULBs and the procurement of SWM Vehicles and equipments for the rest 97 ULBs.

But it is to mention that implementation of 10 SWM Projects for 14 ULBs are running in full swing.

You have had released only 50% of VGF Grant as 1st Installment in the Month of April, 2017 for the above SWM projects. As per our requirement stated in our letter No SUDA-281/2016/146 dated 23.04.2018, 2nd installment for the stated above projects amounting for Rs. 94.16 Cr. may kindly be released as soon as possible, so that we can implement the said projects in time.

Regards,

Director SUDA

Mithilesh Mandal &lt;mkmandalud@gmail.com&gt;

Wed, Jun 13, 2018 at 5:57 PM

To: "Director, SUDA" &lt;sbm.wbsuda@gmail.com&gt;, Manindra Nath Pradhan &lt;wbsudadir@gmail.com&gt;

Cc: Rajendar Jayal &lt;rajjhuni@gmail.com&gt;, vk.jindal@nic.in, sanghamitrab@kpmg.com, "Dewan, Salim" &lt;salimdewan@kpmg.com&gt;

Respected Sir,

Please find attached a letter on the above subject for information and further necessary action.

Regards,

(Mithilesh Kumar Mandal)/(मिथिलेश कुमार मंडल)  
Section Officer (SBM-II)/अनुभाग अधिकारी (एस.बी.एम.-II)  
Ministry of Housing and Urban Affairs/आवासन एवं शहरी कार्य मंत्रालय  
Government of India/भारत सरकार  
Room No. 202-A, C Wing/कमरा संख्या - 202-अ, सी विंग  
Nirman Bhawan/निर्माण भवन  
New Delhi-110011/नई दिल्ली -110011  
Tel:23061437/दूरभाष-23061437  
[Quoted text hidden]

West Bengal (13Jun18).pdf  
711K

Dewan, Salim &lt;salimdewan@kpmg.com&gt;

Wed, Jun 13, 2018 at 6:35 PM

To: "sbm.wbsuda@gmail.com" &lt;sbm.wbsuda@gmail.com&gt;



62

SUDA - 281/2016/416

04.06.2018

From : Director, SUDA &  
State Mission Director, SBM (U)

To : Joint Secretary & Mission Director  
Swachh Bharat Mission (U)  
Ministry of Housing and Urban Affairs, Government of India  
Nirman Bhawan, New Delhi - 110 011

Sub. : Claim for Government of India Share as per Action Plan for different components in 2018-19, under SBM (U) for the State of West Bengal.

Ref.: 1. Your Memo No.: 1/31/2015-SBM dated 2<sup>nd</sup> May 2018  
2. Our Memo No.: SUDA-281/2016/146 dated 23<sup>rd</sup> April 2018

Sir,

As per request, it is being clarified that all the 13 DPRs for 13 new SWM Projects indicated in the minute of the 2<sup>nd</sup> State High Powered Committee Meeting, under Swachh Bharat Mission (Urban), which was held on 28<sup>th</sup> March 2018, at the Conference Hall, Nabanna, had been appraised in all respect by the Chief Engineers of both Municipal Engineering Directorate and Kolkata Metropolitan Development Authority, Urban Development and Municipal Affairs Department, Government of West Bengal, both Technically and Financially.

Again the cost of SWM vehicles and equipments had been considered based on the rates approved either by the Municipal Engineering Directorate or the Kolkata Metropolitan Development Authority, UD & MA Department, Govt. of West Bengal or as per Market Rate analysis.

You are now requested to release the sum of Rs. 332.11 crore for the year 2018-19 as detailed in our memo in reference.

Thanking you.

Yours faithfully,

Director, SUDA &  
State Mission Director, MMB (U)

SUDA - 281/2016/416/1(1)

04 06 2018

Copy forwarded for kind information to:

1 PS to the Principal Secretary, UD & MA Department, Govt. of W B

Director, SUDA

No. 1/31/2015-SBM  
Government of India  
Ministry of Housing and Urban Affairs

61  
Nirman Bhawan, New Delhi  
Dated the 12<sup>th</sup> June, 2018

To  
The Pay & Accounts Officer (Sectt.)  
Ministry of Housing and Urban Affairs  
New Delhi-110011

**Subject: Release of 1<sup>st</sup> installment to Govt. of West Bengal in respect of Solid Waste Management Projects under Swachh Bharat Mission during 2018-19 - reg.**

Sir,

I am directed to convey the sanction of competent authority for release of **Rs.111,82,00,000/- (Rupees One hundred eleven crore and eighty two lakh only)** to Govt. of West Bengal towards release of 50% of 35% VGF as 1<sup>st</sup> installment for **Solid Waste Management Project** under Swachh Bharat Mission (Urban) during 2018-19. Details are as under:-

Sl. No.	Name of Projects	Project Cost	35% VGF	(Rs. in Crore) 1 <sup>st</sup> Installment
1	Durgapur MC	64.31	110.76	55.38
2	Bankura	16.49		
3	Purulia	14.60		
4	Coochbehar	9.35		
5	Burdwan	38.17		
6	Arambag	9.34		
7	Raghunathpur	5.62		
8	Kharagpur	34.07		
9	Panihati	45.22		
10	Kanchrapara	27.03		
11	Baruipur	12.65		
12	Garulia	10.49		
13	Asansol MC (P-II)	29.12		
	<b>Total cost for 13 SWM Projects of 13 ULBs</b>	<b>316.46</b>		
14	<b>Procurement of SWM Vehicles and Equipment for 97 ULBs</b>	<b>322.49</b>	<b>112.87</b>	<b>56.44</b>
			<b>Total =</b>	<b>111.82</b>

2. The sanction will be regulated in accordance with the provisions of GFR, 2017.

3. The expenditure is debitable to Major Head **3601**-(Grants-in-Aid to State Govts.)-**06**-(Centrally Sponsored Schemes)-**101**-(Central Assistance/Share)-**22**-(Swachh Bharat Mission)-**03**-Project Fund-**35**-Grants for creation of Capital Assets under **Demand No. 56** for the year **2018-19** of the Ministry of Housing and Urban Affairs.



4. The amount will be credited to the State Government's account in RBI as per procedure laid down by Ministry of Finance, Department of Expenditure vide O.M. No. F-II (45/76/SC) dated 22.02.1977.
5. In addition to the entire Scheme being governed by the Guidelines of the Swachh Bharat Mission (SBM) which is available at [www.mohua.gov.in](http://www.mohua.gov.in) and following the same while releasing funds to the beneficiaries/ULBs, the release of funds for the **Solid Waste Management** will be restricted to and governed by the guidelines given in **Paragraph 7** of the SBM guidelines.
6. Entry has been made at **Sl. No. 10** of Grant-in-aid Register for the year 2018-19.
7. No U.C. is pending for this project from Govt. of West Bengal.
8. This issues with the approval of Finance Division vide note on **e-file No. 3125021** dated **11/06/2018**.

Yours faithfully,

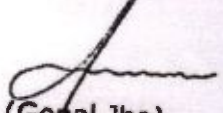

(Gopal Jha)

Under Secretary to the Govt. of India  
Tel: 23062565

**Copy to:-**

1. Director General, Audit Central Revenue and Expenditure, Near ITO, AGCR Building, New Delhi-110002
2. Principal Accounts Officer, Ministry of Housing and Urban Affairs, Nirman Bhawan, New Delhi.
3. Chief Secretary, Government of West Bengal, Kolkata.
4. Shri. M.N. Pradhan, Director, State Urban Development Agency (SUDA), ILGUS Bhavan, Sector-III, H-C Block, Bidhannagar, Kolkata - 700 106
5. Finance Division
6. Sanction file

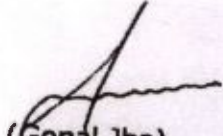

(Gopal Jha)

Under Secretary to the Govt. of India



59

**Minutes of the 2<sup>nd</sup> Meeting of State High Powered Committee  
under Mission Nirmal Bangla (Urban)/Swachh Bharat Mission (Urban)**

Date: 28<sup>th</sup> March 2018

Time: 11.30 AM

Venue: Conference Hall of the  
Chief Secretary at Nabanna

List of the Members and other Participants Present: Placed at Annexure-I

The Chief Secretary to Government of West Bengal and the Chairman of the State High Powered Committee under Mission Nirmal Bangla (Urban)/Swachh Bharat Mission (Urban) chaired the meeting.

At the outset, the Secretary, Urban Development & Municipal Affairs Department, Government of West Bengal welcomed all the members of the Committee and explained the overall plan and activities under Mission Nirmal Bangla (Urban).

Detailed discussion took place on the progress of the 10 nos. of Solid Waste Management Projects of 14 ULBs under implementation, the proposed 13 nos. of Solid Waste Management Projects of 13 ULBs for approval, Strategy for covering all the ULBs to ensure segregation at source, 100% door to door collection and transportation and action plan of the components for the year 2018-19,

**I. Approval of DPRs of Solid Waste Management:**

DPRs of following 13 Solid Waste Management Projects of 13 ULBs of West Bengal have been placed before the Committee for consideration. The SWM Projects are technically appraised by Reputed Institutes/Chief Engineers of the Department. Lands for the projects are available with the ULBs in each case. After detailed deliberation, the Committee has approved the DPRs of following SWM Projects:

Sl. No.	ULB	Estimated Cost (Rs. in Lakh)		
		Bulk purchase of Equipments and Vehicles	Construction of SLF, Compost /Bio-gas/Vermi-Compost Plant	TOTAL DPR COST
1	Durgapur MC	2553.47	3877.82	6431.29
2	Bankura	559.63	1088.9	1648.53
3	Purulia	392.72	1066.82	1459.54
4	Coochbehar	266.11	669.16	935.27
5	Burdwan	1683.37	2133.2	3816.57
6	Arambag	298.82	634.86	933.68
7	Raghunathpur	201.61	360.43	562.04
8	Kharagpur	1542.31	1865	3407.31
9	Panihati	1241.04	3281.35	4522.39
10	Kanchrapara	824.37	1879.05	2703.42
11	Baruipur	372.2	892.68	1264.88
12	Garulia	430.4	618.85	1049.25
13	Asansol MC (P-II)	0	2911.69	2911.69
	<b>TOTAL</b>	<b>10366.05</b>	<b>21279.81</b>	<b>31645.86</b>



It was decided that beyond the Government of India share of 35%, the remaining will be borne by the State Government and ULB. This fund sharing pattern between the State Government and ULB will remain same as approved for the earlier Projects i.e. 5% share will be borne by the ULBs having below 10 Lakh Population and 10% share will be borne by the ULBs having above 10 Lakh Population, and the remaining fund will be borne by the State Government as Matching State Share & Additional State Share.

It was decided that for these projects, all the vehicles and equipments will be procured centrally from the end of State Urban Development Agency (SUDA) and construction of Sanitary Landfill & Processing Plants will be done by the ULBs under the supervision of Municipal Engineering Directorate & Kolkata Metropolitan Development Authority.

**2. Procurement of SWM Vehicles and Equipments for 97 ULBs:**

It was decided that to ensure Segregation at source, 100% door to door collection and Transportation in all the ULBs, procurement of all the SWM Vehicles and Equipments of all the ULBs will be done Centrally from SUDA. After that DPR for the ULBs will be prepared for establishment of Processing Plant and Sanitary Landfill site subject to availability of suitable Land.

After detailed deliberation, the Committee has approved the following two DPRs for procurement of SWM Vehicles and Equipments for all the remaining ULBs of West Bengal:

- i. A DPR for Improvement of Transportation System of Municipal Solid Waste of the ULBs with total Project Cost of Rs. 64.49 Crore, is prepared by SUDA in consultation with the ULBs and appraised by Municipal Engineering Directorate, Government of West Bengal. Procurement for 23 nos. 8 CuM Movable Compactors, 117 nos. 10 CuM Dumpers, 179 nos. 2.2 CuM Fuel Operated Tippers and 663 nos. Battery Operated Hydraulic Tippers are in progress. In this respect, work order for 23 nos. 8 CuM Movable Compactors has already been issued. Re-tender for the remaining items have been done due to non availability of successful bidders in 1<sup>st</sup> call.
- ii. A DPR for ensuring Segregation at source, 100% door to door collection and Transportation in all the ULBs with total Project Cost of Rs. 258 Crore, have been prepared by SUDA in consultation with the ULBs and appraised by Municipal Engineering Directorate, Government of West Bengal. Procurement to be made for 10 ltrs Household Bins, 100-120 Ltr. Litter Bin, 240-660 ltrs. Community Bin, Tricycle Van, Battery Operated Cart, Wheel Barrow, Auto Tipper, Compactor (Movable), Dumper, Tractor, TT Container, Jetting cum Suction Machine, Road Sweeping Machine, Cesspool, Loader cum Back Hoe and Safety Measures etc.

*[Handwritten signature]*



3. Annual Action Plan for the Year 2018-19:

The Committee has approved the Annual Action Plan of the Components for the year 2018-19 amounting to total Gol Share of Rs. 237.95 Crore, which will be submitted to Government of India. Details of the Annual Action Plan of all Components for 2018-19 approved by SHPC :

Sl No.	Components	Action Plan	Estimated Project Cost	Total Central Share (Rs in Crore)
1	Community Toilet	Construction of 2000 Seats	Rs. 19.60 Crore (@98000/- per seat)	7.84
2	Public Toilet	Construction of 1000 Toilet Seats	Rs. 9.80 Crore (@98000/- per seat)	3.92
		Construction of 2000 Urinal Seats	Rs. 6.4 Crore (@32000/- per seat)	2.56
3	Solid Waste Management (SWM)	13 Nos of New SWM Projects of 13 ULBs	Rs. 316.46 Crore	110.76
		Procurement of SWM Vehicles for Improvement of Transportation System of Municipal Solid Waste of the ULBs	Rs. 64.49 Crore	22.57
		Procurement of all the SWM Vehicles and Equipments for 97 ULBs to ensure Segregation at Source, 100% Door to Door Collection and Transportation of Grabage	Rs. 258 Crore	90.30
TOTAL				237.95



4. Claim of Fund from GoI in the Year 2018-19:

The Committee has approved the Claim of Fund amounting to Rs. 332.11 Crore from Government of India in the year 2018-19, which will be submitted to Government of India. Details of Claim of Fund from Government of India in the year 2018-19 approved by SHPC:

*Rs. in Crore*

Sl No	Financial Year	Installment	SWM Amount	CT Amount	PT Amount	PT-Urinal Amount	Total Amount
1	2017-18	2nd	94.16	0	0	0	94.16
2	2018-19		223.63	7.84	3.92	2.56	237.95
TOTAL			295.22	7.84	3.92	2.56	332.11

5. Miscellaneous:

- As per direction of Hon'ble Chief Minister to Government of West Bengal a 'Clean & Green City/Ward Competition has been designed to create and maintain a healthy and beautiful environment in the cities and also to develop a competitive environment among the Cities and also among the Wards within the City. In the discussion, it was decided that in the evaluation parameters, cleanliness of Schools should be added.
- The Chief Secretary to Government of West Bengal raised an issue that the market areas & its nearby drains of Darjeeling City remain very much dirty due to accumulation of wastes during <sup>peak</sup> ~~peak~~ season for the tourists. . In this connection the Secretary, UD & MA Department has explained the activities already taken up through an Integrated Solid Waste Management project under State Plan Fund for Darjeeling City. In the project all kinds of vehicles and equipments are being procured for ensuring segregation at source, 100% door to door and market waste collection and regular Road sweeping. Bio Gas Plant are being constructed for processing of Bio Degradable Wastes and the recyclable items will be sold out. .

Meeting ended with thanks to and from the chair.

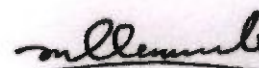

(Malay De)

Chief Secretary to Government of West Bengal  
& Chairman, SHPC, MNB (U)



## Annexure-I

### List of Members and Other Participants Present

1. Sri Malay De, IAS, Chief Secretary, GoWB
2. Sri Harekrishna Dwivedi, IAS, Additional Chief Secretary, Finance Department
3. Sri Sanjay K Thade, IAS, Principal Secretary, Backward Classes Welfare Department
4. Sri Arnab Roy, IAS, Principal Secretary, Environment Department
5. Sri D. Nariala, IAS, Principal Secretary, School Education Department
6. Sri Khalil Ahemed, IAS, Municipal Commissioner, Kolkata MC.
7. Sri Onkar Singh Meena, IAS, Secretary, UD & MA Department
8. Sri Arvind Mina, IAS, S.P.D., PBSSM, School Education Department
9. Sri Sutanu Kar, IAS, Director, SUDA
10. Smt. Pragyan Bharati, Wash Specialist, UNICEF
  
11. Sri J. Chattopadhyaya, D.L.B., UD & MA Department
12. Sri Amit Das, Chief Engineer, MED, UD & MA Department
13. Sri B. N. Kar, Additional Director, ILGUS, UD & MA Department
14. Sri Subbasish Chattopadhyaya, Director General (SWM), Kolkata MC
15. Sri K. Ghosh Dastidar, Executive Engineer, Kolkata MC
16. Sri Bijay Krishna Pal, Executive Engineer, SUDA
17. Sri Saumya Bandyopadhyay, Assistant Engineer, M.E.D, UD & MA Department
18. Sri S S S Gous, Programme Coordinator, SUDA
19. Dr. Sujay Mitra, Chief Manager - Planning & Monitoring, SUDA

No. 20/1/2016-SBM-1  
Government of India  
Ministry of Urban Development

18<sup>th</sup> July 2016

**OFFICE MEMORANDUM**

**Sub: Revisions/ Modifications of the operational guidelines of Swachh Bharat Mission (Urban)**

This is to notify that the following changes have been made to the guidelines with respect to Swachh Bharat Mission (Urban):

1. State High Powered Committees (SHPCs) are given the flexibility to re-determine targets for IHHLs and CTs, subject to overall state-wise funds envelope (sum of allocation under IHHL and CTs, for the entire mission period) remaining unchanged.
2. Increase in base unit cost of CTs to Rs 98,000 per seat, wherein VGF/Grant will be upto 40% of project cost (i.e. VGF/Grant of Rs 39,200 per seat). This will be subject to overall state-wise funds envelope (sum of allocation under IHHL and CTs, for the entire mission period) remaining unchanged. This marks a shift from monitoring of toilet construction to monitoring of ODF status achievement.
3. Extension of VGF/Grant of upto 40% as available for CTs to Public Toilet projects as well (i.e. VGF/Grant of Rs 39,200 per seat). Unit cost of PTs to be same as CTs. Targets for PT to be set under CT component. This will be subject to overall state-wise funds envelope (sum of allocation under IHHL and CTs, for the entire mission period) remaining unchanged.
4. Inclusion of urinals in ODF component, wherein VGF/grant of upto 40% to be given on lines of CTs/PTs, and base cost of urinals to be Rs. 32,000 per unit (i.e. VGF/Grant of Rs 12,800 per unit). Targets for urinals to be set under CT component. This will be subject to overall state-wise funds envelope (sum of allocation under IHHL and CTs, for the entire mission period) remaining unchanged.
5. The central assistance for Municipal Solid Waste Management component be raised from present 20 percent to 35 percent. This will be subject to overall state-wise funds envelope, for the entire mission period, for SWM remaining unchanged.

This issues with the approval of competent authority.

  
(V.K. Kushwaha)  
18.7.16  
Tel: 23062654

Under Secretary to the Government of India

To:

- 1) Chief Secretaries of all States/ Union Territories
- 2) Principal Secretaries/ Secretaries of Urban Development of all States/ Union Territories
- 3) Mission Directors (SBM) of all States/ Union Territories

Copy for information to: (i) PSO to Secretary (UD) (ii) JS&FA, MoUD (iii) JS (SBM) (iv) Director (SBM-I)/DS (SBM-II)

54  
Add. HD (SBM)  
CRNK  
JPA  
for no. M  
20/1/16





सत्यमेव जयते

**Government of India**



सत्यमेव जयते

Government of India

**Ministry of Urban Development**

Guidelines for

**Swachh Bharat Mission (SBM)**



एक कदम स्वच्छता की ओर

December 2014

**CONTENTS:**

<b>1. INTRODUCTION</b>	<b>3</b>
<b>2. SWACHH BHARAT MISSION (SBM) URBAN OVERVIEW</b>	<b>3</b>
2.1 Mission Objectives	3
2.2. Duration of the Mission	4
2.3. Mission components	4
2.4. Mission Coverage: cities and target population	4
2.5. Mission Strategy	4
2.6 Mission Outlay	5
<b>3. CONCEPT SANITATION STRATEGY</b>	<b>6</b>
<b>4. SBM (URBAN) COMPONENT I: PROVISION OF HOUSEHOLD TOILETS</b>	<b>6</b>
<b>5. SBM (URBAN) COMPONENT II: COMMUNITY TOILETS</b>	<b>9</b>
<b>6. SBM (URBAN) COMPONENT III: PUBLIC TOILETS</b>	<b>10</b>
<b>7. SBM (URBAN) COMPONENT IV: SOLID WASTE MANAGEMENT</b>	<b>11</b>
<b>8. SBM (URBAN) COMPONENT V: IEC &amp; PUBLIC AWARENESS</b>	<b>13</b>
<b>9. SBM (URBAN) COMPONENT VI: CAPACITY BUILDING AND ADMINISTRATIVE &amp; OFFICE EXPENSES (A&amp;OE)</b>	<b>14</b>
<b>10. FUNDING PATTERN AND FINANCIAL PROCESS</b>	<b>15</b>
10.1. Funding pattern	15
10.2. Clarification on Grant v/s VGF	16
10.3. Allocation of funds to States / UTs	17
10.4. Disbursal of funds to States / UTs and ULBs	18
10.5. Sanction of projects (DPRs)	19
<b>11. MISSION MANAGEMENT STRUCTURE</b>	<b>20</b>
11.2. SBM (Urban) at the National Level	20
11.3. SBM (Urban) at the State level	21
11.3 ULB Level	22
<b>12. MONITORING &amp; EVALUATION (M&amp;E)</b>	<b>23</b>
<b>13. Logo and Tag Line</b>	<b>23</b>
<b>14. ANNEXURES I-V</b>	<b>24-53</b>

## 1. Introduction

1.1. According to Census 2011 India's urban population is 377 million or 31% of the total population. These numbers are expected to increase to 600 million by 2031. The Census 2011 also showed that in 4,041 statutory towns, close to eight million households do not have access to toilets and defecate in the open (7.90 million). Weak sanitation has significant health costs and untreated sewage from cities is the single biggest source of water resource pollution in India. This indicates both the scale of the challenge ahead of the Indian cities and the huge costs incurred from not addressing them.

1.2. The Swachh Bharat Mission (SBM) emanates from the vision of the Government articulated in the address of The President of India in his address to the Joint Session of Parliament on 9th June 2014:

"We must not tolerate the indignity of homes without toilets and public spaces littered with garbage. For ensuring hygiene, waste management and sanitation across the nation, a "Swachh Bharat Mission" will be launched. This will be our tribute to Mahatma Gandhi on his 150<sup>th</sup> birth anniversary to be celebrated in the year 2019"

SBM is being implemented by the Ministry of Urban Development (M/o UD) and by the Ministry of Drinking Water and Sanitation (M/o DWS) for urban and rural areas respectively. These guidelines are for implementation of Swachh Bharat Mission (Urban).

## 2. Swachh Bharat Mission (SBM) Urban Overview

### 2.1. Mission Objectives

- 2.1.1. Elimination of open defecation
- 2.1.2. Eradication of Manual Scavenging
- 2.1.3. Modern and Scientific Municipal Waste Management
- 2.1.4. To effect behavioral change regarding healthy sanitation practices
- 2.1.5. Generate awareness about sanitation and its linkage with public health
- 2.1.6. Capacity Augmentation for ULB's
- 2.1.7. To create an enabling environment for private sector participation in Capex (capital expenditure) and Opex (operation and maintenance)



## 2.2. Duration of the mission

The Mission will be in force till 2<sup>nd</sup> October 2019

## 2.3. Mission components

The Mission has the following components:

- 2.3.1. Household toilets, including conversion of insanitary latrines into pour-flush latrines;
- 2.3.2. Community toilets
- 2.3.3. Public toilets
- 2.3.4. Solid waste management
- 2.3.5. IEC & Public Awareness
- 2.3.6. Capacity building and Administrative & Office Expenses (A&OE)

**By Public Toilets**, it is implied that they are to be provided for the floating population / general public in places such as markets, train stations, tourist places, near office complexes, or other public areas where there are considerable number of people passing by.

**By Community toilets**, it is implied that a shared facility provided by and for a group of residents or an entire settlement. Community toilet blocks are used primarily in low-income and/or informal settlements / slums, where space and/or land are constraints in providing a household toilet. These are for a more or less fixed user group.

## 2.4. Mission Coverage: CS and target population

2.4.1. All Statutory towns will be covered under the Mission. Definition of statutory towns is at **Annexure I**.

## 2.5. Mission Strategy

2.5.1. Comprehensive Sanitation Plan, which includes

- (a) City Level Sanitation Plans
- (b) State Sanitation Concept As per **Annexure IV**
- (c) State Sanitation Strategy

2.5.2. Behavioral Change Strategy<sup>EC</sup>

2.5.3. Enabling Environment for private sector participation

2.5.4. Capacity Building

2.5.5. Special focus groups : The State Governments shall pursue the following:

- i. All manual scavengers in urban areas are identified, insanitary toilets linked to their employment are upgraded to sanitary toilets, and that the manual scavengers are adequately rehabilitated.
- ii. In their efforts to streamline and formalize SWM systems it shall be the endeavor of ULBs that the informal sector workers in waste management (rag pickers) are given priority to upgrade their work conditions and are enumerated and integrated into the formal system of SWM in cities.
- iii. All temporary accommodation for migrants and the homeless in urban areas have adequate provision for toilets either on the premises or linked to a public / community toilet.
- iv. Mandating that construction labour in urban areas have access to temporary toilets at all sites in urban areas, buildings, parks and roads where construction / maintenance work is taking place or where construction labour is temporarily housed.
- v. Priority shall be accorded pro-actively to cover households with vulnerable sections such as pensioners, girl children, pregnant and lactating mothers.

## 2.6. Mission Outlay

The estimated cost of implementation of SBM (Urban) based on unit and per capita costs for its various components is Rs. 62,009 Crore. The Government of India share as per approved funding pattern amounts to Rs. 14,623 Crore. In addition, a minimum additional amount equivalent to 25% of Gol funding, amounting to Rs. 4,874 Crore shall be contributed by the States as State/ULB share. The balance funds is proposed to be generated through various other sources of fund which are, but not limited to:

- a. Private Sector Participation
- b. Additional Resources from State Government/ULB
- c. Beneficiary Share
- d. User Charges
- e. Land Leveraging
- f. Innovative revenue streams
- g. Swachh Bharat Kosh
- h. Corporate Social Responsibility
- i. Market Borrowing
- j. External Assistance

### 3. Concept Sanitation Strategy:

It is understood that without a proper **city sanitation plan** and resulting **state sanitation strategy**, as indicated in National Urban sanitation policy-2008, comprehensive planning cannot be achieved to attain the objectives of Swachh Bharat Mission. However, both the activities require time and wide consultation at various levels including citizen engagements. It is also understood that although many states and cities have prepared these plans and strategy, many more have not done so.

In order to give a quick start to the Swachh Bharat Mission, it is, therefore proposed that all states may submit a **brief concept Note on state sanitation strategy**, as given in the **Annexure IV** of these guidelines as a part of their initial proposal, in order to claim their first installment for individual household toilets, IEC and Capacity Building as well as the revolving fund for other components.

The concept note and proposal shall be submitted online to MoUD by state governments by 30 January 2015.

The states should however, simultaneously start preparing City sanitation plans for each city and State Sanitation strategy as per National Urban sanitation Policy 2008 as these will be required before any further release can be made to the states.

### 4. SBM (Urban) Component -I: Household toilets

#### 4.1. SBM (Urban) aims to ensure that

- a) No households engage in the practice of open defecation,
- b) No new insanitary toilets are constructed during the mission period and
- c) Pit latrines are converted to sanitary latrines.

The Target Group for construction of household units of Toilets, thus, is:

- (i) 80% of urban households engaging in open defecation
- (ii) All households with insanitary latrines
- (iii) All households with single-pit latrines

These will be targeted under this component for the construction of household toilets or individual household latrines during the mission period. The remaining 20% of households practicing open defecation are assumed to be catered by community toilets due to constraints of space.

4.2. **Household toilets** constructed under SBM (Urban) will have two main structures – the toilet *superstructure* (including the pan and water closet), and the



*substructure* (either an on-site treatment system, or a connection to existing underground sewerage system).

4.2.1. Whenever a sewerage system is available within 30 metres from the proposed household toilet, only the toilet superstructure may be constructed and connected to the existing sewerage system. ULBs must facilitate these connections for household toilets under SBM (Urban), wherever applicable and economical.

4.2.2. In the event that a sewerage system is not available within 30 meters from the proposed household toilet, in addition to the construction of the toilet superstructure, an on-site treatment system (such as twin pits, septic tanks, bio-digesters, or bio-tanks) should also be constructed for the collection, treatment and/or disposal off sewage at, or near the point of generation.

4.2.3. ULBs should ensure that all household toilets being constructed under SBM are built in tandem with water supply arrangements in ULBs. Beneficiary households will be responsible for the operation and maintenance of the household toilets. Suggested technical specifications, technologies and tentative cost of household toilets are available at **Annexure II**

4.3. For this component, **beneficiary** shall mean any household that does not have access to an individual household toilet or has an insanitary toilet (dry/ *bahou* and single pit latrine). No other criteria is to be applied:

4.3.1. Selection of Beneficiary Household shall be as per the strategy adopted by ULB under the guidance of state government. However, the following guiding principals may be followed:

- (i) Initially, a campaign to create awareness may motivate beneficiaries to come forward on their own. This should be taken at the ULB level and followed up by accepting a simple application and undertaking, to be verified within 7 days and approved at ULB level.
- (ii) ULBs are expected to carry out a house-to-house survey. In so doing they shall also take into consideration Census 2011 data or any recent survey available to them. This baseline data shall be put in public domain by 15.02.2015.
- (iii) Any Claims and objections received shall be addressed in a transparent manner and continuous modifications can made in the baseline data.
- (iv) Based on this house to house survey, all households practicing open defecation shall be identified and ULB's need to approve either a Household toilet or plan for community toilets for each of such identified household/group of household.

4.3.2. Beneficiary households will be targeted under this scheme irrespective of whether they live in authorized/unauthorized colonies or notified / non-notified slums. Under SBM (Urban), tenure security issues are to be de-linked with benefits.

4.3.3. The states and ULB's must ensure that the maximum number of beneficiaries from individual household toilets will be normally limited to the numbers indicated in the Census of India 2011 for each town.

4.4. Central government incentive for the construction of household toilets will be Rs. 4,000 per household toilet for each identified beneficiary household.

4.4.1. 50% of the Central Government incentive ( Rs. 2,000/-) will be released to the identified beneficiary household by the ULB as 1<sup>st</sup> installment on approval by the ULB along with share of the state government. There is no bar on releasing any extra funds at any stage using additional resources generated/provided by state government/ ULB.

4.4.2. The ULB shall verify each application before releasing any incentive. Verification of the application should be completed within 7 working days of its submission of application by the beneficiary.

4.4.3. The remaining 50% of Central Government incentive as 2<sup>nd</sup> installment should be released to the identified beneficiary household along with the State Government's incentives upon verification of physical progress of construction of the household toilet. The actual process of verification will be as per the directions of the respective State Government.

4.4.4. Final Verification of the construction of the household toilet should be supported by location-based technologies, wherein self-attested geo-tagged photographs of the construction, along with the applicant are taken out. These photographs must be uploaded to the SBM (Urban) MIS and be monitored by the ULBs and the States.

4.4.5. All financial incentives (government and /or private) for this component will be deposited directly (by electronic clearing service) into the bank accounts of the beneficiary households (including accounts opened under the *Pradhan Mantri Jan Dhan Yojana*). No cash/cheque disbursals shall take place.

The ULBs should ensure that financial incentives to beneficiary households are transferred in a timely and hassle-free manner. The State government should evolve standard norms for this throughout the state and ensure the monitoring of its implementation.

## 5. SBM (Urban) Component II: Community toilets

5.1. Under SBM (Urban), it is estimated that about 20% of the urban households in cities, who are currently practicing open defecation are likely to use community toilets as a solution due to land and space constraints in constructing individual household latrine.

5.2. Community toilet blocks will consist of a given number of toilet seats, as per requirements, toilet superstructure including the pan and water closet, and a substructure (either an on-site treatment system, or a connection to underground sewerage/septage system) shared by all the toilet seats and facilities for hand wash.

5.2.1. Care should be taken to ensure that these facilities have adequate provision for separate toilets and bathing facilities for men, women and facilities for the disabled (e.g. ramp provision, braille signage, etc.).

5.2.2. The norms for connection of the superstructure to an on-site system or connection to an underground sewerage system as defined in paragraphs 4.2.1 and 4.2.2 above will apply here.

5.2.3. ULBs should ensure that all community toilets being constructed under SBM (Urban) are built in tandem with water supply arrangements in ULBs. Suggested technical specifications, technologies and tentative cost of community toilets are available at **Annexure II**.

5.3. For this component, **beneficiaries** shall be groups of households ("beneficiary household group") in urban areas whose members practice open defecation and who do not have access to household toilet, and for whom the construction of individual household toilets is not feasible. Beneficiary household groups under this component of SBM (Urban) shall be identified by the procedure as designed by the ULB. This may be application based or survey based, with or without participation of community based organisations. Involvement of civil society organisations is to be encouraged. NGO's, Area, Ward or Mohalla Sabha's may be used for this purpose. Beneficiary household groups will be targeted under this scheme irrespective of whether they live in authorized/unauthorized colonies or notified / non-notified slums. Under SBM (Urban), tenure security issues are to be de-linked with benefits.



94

5.4. Once a sufficient number of households are identified as a group, the ULB shall identify suitable piece of land adjoining their houses/dwelling and design the toilet block. Efforts should be made to look into all possible sources of revenue generation by leveraging land ,use of rooftop or any other means.

5.5. Central government incentive for the construction of community toilets will be in the form of 40% Grant/VGF, for each community toilet block constructed. The remaining funds have to be generated as indicated in para 2.6 above.

5.6. Projects will be prepared and sanctioned by ULBs. In the entire project approval and procurement process, all provisions and procedures as prescribed by respective State Governments for ULBs must be followed in their entirety. The entire approval procedure except for release of Central funds will end at the ULB level. To this end the States are required to empower the ULBs if not already done so. This includes the delegation of powers to allot land (for this purpose) to ULB's and mechanisms to leverage this land to make the Community Toilet a viable project.

5.7. All community toilets constructed under SBM must have a minimum 5 year maintenance contract.

5.8. States will contribute a minimum of 25% funds towards community toilet projects to match 75% Central Share. (10% in the case of North East States and special category states).

## **6. SBM (Urban) Component -III: Public Toilets**

6.1. Under SBM (Urban), States and ULBs will ensure that a sufficient number of public toilets are constructed in each city. All prominent places within the city attracting floating population should be covered.

6.2. Care should be taken to ensure that these facilities have adequate provision for men, women and facilities for the disabled (e.g. ramp provision, braille signage, etc.) wherever necessary. Suggested technical specifications, technologies and tentative cost of public toilets are available at *Annexure II*.

6.3. ULBs should ensure that all Public Toilets being constructed under SBM (Urban) are built in tandem with water supply arrangements in ULBs.

6.4. There will be no Central Government incentive support for the construction of public toilets under SBM (Urban). States and ULBs are encouraged to identify land for public toilets, and leverage this land and advertisements to encourage the private

sector to construct and manage public toilets through a PPP agreement. Additional funding support by any means other than Gol grant can be used for public toilets.

6.5. The Projects will be prepared, sanctioned and implemented by ULBs. In the entire project approval and procurement process, all provisions and procedures as prescribed by respective State Governments for ULBs must be followed in their entirety. The entire approval procedure should end at the ULB level. To this end the States are required to empower the ULBs if not already done so. This includes the delegation of powers to allot land (for this purpose) to ULB's and mechanisms to leverage this land to make the Public Toilet a viable project.

6.6. All Public Toilets constructed under SBM must have a minimum 5 year maintenance contract.

## **7. SBM (Urban) Component IV: Solid Waste Management**

7.1. Municipal Solid Waste Management (MSWM) refers to a systematic process that comprises of waste segregation and storage at source, primary collection, secondary storage, transportation, secondary segregation, resource recovery, processing, treatment, and final disposal of solid waste. The Manual on Municipal Solid Waste Management, 2000 published by M/o UD and revised from time-to-time, may be referenced for DPR formulation and implementation.

7.2. ULB's are to prepare DPR for Solid waste management of their city in consultation with state governments. Smaller cities can form clusters to become viable entities to attract private investment. 100% Cost reimbursement for preparing the DPR shall be done by Gol as per unit cost and norms set up by NARC.

7.3. State governments may handhold ULB's in quickly preparing DPR's for SWM by empanelling /shortlisting /identifying private or government agencies for the same.

7.4. The DPR's should be bankable, having a viable financial model. These will be prepared emanating from the needs identified in the City Sanitation Plan. DPRs should be aligned with Govt. of India's goals outlined in the NUSP 2008, SWM rules, advisories, CPHEEO manuals (including cost-recovery mechanisms), O&M practices and Service-level Benchmark advisories released by M/o UD from time to time. Street Sweeping and litter control interventions will be part of DPR which is essential for a clean city.

7.5. In order to promote projects of waste to energy, it is clarified that the central government Grant / VGF may also be used for such projects, either upfront or as generation based incentive for power generated for a given period of time.

7.6. The State High Powered Committee (HPC) will authorize institutes of national repute for appraisal of DPRs for the technical and economic appraisal of DPRs for projects recommended by ULBs. No appraisal will be done by MoUD. The cost of DPR appraisal by these institutes shall be an admissible component under administrative costs, subject to norms as approved by MoUD.

7.7. The performance and quality of appraisal by these identified and authorized institutes will be evaluated and monitored by HPEC as well as NARC and corrective actions taken wherever necessary.

7.8. The State Level high power committee will approve the DPR as well as the financial model of solid waste management.

7.9. The implementation of SWM projects will be as per directions of State Level High Power Committee.

7.10. Central government incentive for the SWM projects will be in the form of a maximum of 20% Grant / VGF for each project. The remaining funds have to be generated as indicated in para 2.6 above.

7.10.1. While considering projects under MSWM it will be ensured that there is no duplication in terms of funding under any other scheme or programme.

7.10.2. Detailed technical and financial appraisal of the DPRs will be carried out in the manner prescribed in paragraph 10.5.4. O&M arrangements for the project shall necessarily be an integral part of the project in the DPR.

7.10.3. SWM projects will be sanctioned by the State level HPC which shall include a representative of the MoUD. In the entire project approval and procurement process, all provisions and procedures as prescribed by respective State Governments must be followed in their entirety. The entire approval procedure for MSW projects except for release of Central funds will end at the State Level.

7.10.4. The States shall be free to choose the technology for SWM projects, toilets and street sweeping. The Ministry of Urban Development shall, from time to time, bring to the notice of the States, through advisories and manuals, and other consultative mechanisms, various options available in these fields.



41

7.10.5. States will contribute a minimum of 25% funds for SWM projects to match 75% Central Share.(10% in the case of North East States and special category states).

## **8. SBM (Urban) Component -V: IEC & Public Awareness**

8.1. A key strategy under SBM (Urban) is behavior change communication to ensure that sanitation as an issue is mainstreamed with the general public at large and should cover issues of open defecation, prevention of manual scavenging, hygiene practices, proper use and maintenance of toilet facilities (household, community or otherwise), etc., and its related health and environmental consequences. Communication material for behavior change shall be designed in consultation with the M/o Information and Broadcasting, M/o Health & Family Welfare, and should be in sync with the material being used under SBM (Rural).

8.2. A total of 15% of the total central allocation will be earmarked for this component. Of this, 12% will be earmarked for States to undertake massive public awareness campaigns on sanitation and establishing its link to public health, hygiene and the environment through various means including - radio, social media, documentaries, plays, workshops, etc. The remaining 3% will be earmarked for the MoUD to draw a national media campaign and developing standard campaign tools for effective awareness and communication on sanitation.

8.3. Expenditure on Newspaper and TV is not an admissible item under this component for the state government or for the ULB's as this is taken care by government of India ministries and organisations.

8.4. States shall prepare an annual action plan, with details of State funding commitment, for Public Awareness & IEC and State HPC shall approve it. At least 50% of the IEC fund in each annual plan, as approved by State HPC, must go to the ULB's for IEC activities at the grass root level.

8.5. HPEC at State level shall be the competent authority to authorize and delegate administrative powers for use of the state level funds within the approved plan. ULB's shall be competent to spend the minimum 50% part of the ULB level funds, as per approved plan.

8.6. Under no circumstance shall this fund be utilized for purchase of vehicles, construction and maintenance of buildings, creation of posts and payment of salary, and purchase of furniture and fixtures.

States will contribute a minimum of 25% funds towards IEC & Public awareness to match 75% Central Share (10% in the case of North East States and special category states) in each annual plan.

## **9. SBM (Urban) Component VI : Capacity Building and Administrative & Office Expenses (A&OE)**

9.1. 3% of the total Central Government allocation under the mission will be earmarked for capacity building, administrative and office expenses of States and ULBs.

9.2. 2% of the total Central Government allocation under the mission will be utilized at MoUD level for capacity building, convening national and regional workshops, various awards and best practice recognition, programme research, studies, international cooperation for capacity building and technology development, A&OE and various eligible purposes in consultation with the Integrated Finance Division (IFD) of the M/o UD.

9.3. States shall propose extensive capacity building activities to be implemented in a mission-mode manner, which will enable the progressive achievement of objectives of SBM (Urban) in a time-bound manner. These will be specified in the comprehensive annual action plan prepared by each state. This will be approved by State Level High Power Committee after sharing and considering suggestions from MoUD. At least 50% of this fund, in each annual plan, as approved by State HPC, must go to the ULB's for activities at the ULB level.

9.4. HPEC at State level shall be the competent authority to authorize and delegate administrative powers for use of these funds. ULB's shall be competent to use the minimum 50% fund, as per approved plan, passed on to them.

9.5. States will be encouraged to use other available capacity building funds to dovetail or integrate capacity building activities of ULB's.

9.6. States and ULBs should identify relevant officials (both senior level officials and field-level functionaries) for training and draw up a calendar of training for them. It will be the responsibility of the State Mission Director to ensure that identified officials undergo adequate capacity building / training to ensure the success of SBM (Urban) in the state. Additionally, states should also identify relevant officials / persons capable of spreading the training on sanitation under SBM (Urban) as "master trainers" who can attend central government training on SBM (Urban) and then organize subsequent training to diffuse the message of SBM (Urban) in the states.

9.7. All support structures for implementing the mission at the state and ULB levels defined in the Mission Management Structure (section 11 of the SBM (Urban) guidelines), i.e., the Programme Management Units (PMUs) at the State level, the Programme Implementation Units (PIUs) at the city level, and Independent Project Review & Monitoring Agencies (IPRMA) etc., engaged on an outsourced basis, shall be funded under this head.

9.8. Under no circumstance shall this fund be utilized for purchase of vehicles, construction and maintenance of buildings, creation of posts and payment of salary, and purchase of furniture and fixtures.

9.9. States will contribute a minimum of 25% funds towards Capacity Building and Administrative & Office Expenses (A&OE) to match 75% Central Share.(10% in the case of North East States *and special category states*) in each annual plan.

## 10. Funding pattern and financial process

### 10.1. *Funding pattern: Guiding Principals:*

- a) First installment will be released to states on receipt and acceptance of proposal containing the brief concept state sanitation strategy as given in **Annexure IV**.
- b) For House Hold Toilets, Funds in the first installment will be released as per number of beneficiary household identified, in the concept sanitation plan, at the rate of Rs. 2000/- Central assistance.
- c) For Community Toilets and Solid Waste Management Projects, Adequate funds will be released on the proposal of the State Government for SWM and Community toilet projects. It will be ensured that funds do not remain parked with the state governments. Govt share of grant / VGF may be drawn from this pool fund maintained at state level. This will be replenished on demand by states based on progress.
- d) For IEC, Capacity Building and Administrative expenditure, appropriate percentages of (a) and (b) above shall be added to the first installment.
- e) States will contribute a minimum of 25% funds towards all components to match 75% Central Share. This will be 10% in the case of North East and special category States.
- f) Subsequent installments shall be released based on utilization certificates of previous grants, physical and financial progress and other indicators as approved and desired by the National Advisory & Review Committee (NARC).



## 10.2. Clarification on Grant v/s VGF

10.2.1. Under Swachh Bharat Mission, projects under PPP mode are encouraged, to invite private capital in urban infrastructure as well as to bring in private sector efficiency in delivery of urban services and O & M. It is also understood that in the current scenario, there may be a requirement for viability gap funding. For solid waste management, revenue streams such as Compost from organic waste, recycled construction material from C & D waste, Power from waste to energy plants can be leveraged.

10.2.2. All ULB's must first explore possibility to take up the projects in a PPP mode for the above reasons. Government of India funds as per prescribed funding pattern will be available for claiming VGF.

10.2.3. State governments can also add or generate funds for ULB's as additional incentives over and above minimum 25% share required to make the projects viable.

10.2.4. Release of VGF grants will be as per contractual arrangement with the private partner and as approved by state government. However, it will be ensured that funds do not remain parked with the state governments.

10.2.5. Adequate funds will be released on acceptance of the proposal of the State Government for SWM and Community toilet projects. ULBs will initiate project preparation and bidding as per the guidelines for community toilets and SWM.

10.2.6. States will release the Central Government share of VGF adding their share in conformity with the contractual requirements of the project taken up on PPP mode.

10.2.7. In case state government feels that a project is not suitable to be taken under PPP methodology, it may then consider the Gol share (as per funding pattern) to be treated as Grant from Gol to the ULB. It will be up to the state government and ULB to arrange for the balance resources for the project, which must be ensured at the time of approving a project.

10.2.8. For PPP Projects, state governments to follow their own policy and rules. No project shall be referred to Government of India.

### 10.3. Allocation of funds to States / UTs

10.3.1. The mission will be implemented with the following classification of funding to states:

S. No.	Classification	Percentage Allocation (Central Govt. funding)	Total Amount for Mission Period Rs. Crore
i.	Project Fund based on Normative Criteria	60%	8773.80
ii.	Performance Fund based on Performance Matrix	20%	2924.60
iii.	Public Awareness & IEC Activities	15%*	2193.45
iv.	Capacity Building & A&OE	3%	438.69
v.	Research, Capacity Building & A&OE (M/o UD)	2%	292.46

\*3% of which to be retained by M/o UD

10.3.2. The **Project Fund** specified in 10.3.1(i) above shall be allocated as follows:

i. The distribution of the Project fund will be as under: (Rs. in Crore.)

a.	Project Funds for States other than the North-East	80%	7019.04
b.	Project Funds to North-East States	10%	877.38
c.	Flexi Funds*	10%	877.38

\*Flexi Funds in terms of the Department of Expenditure OM No. F.No.55(5)/PF.II/2011 dated 06.01.2014) will be available to states

- ii. Where ever it is required for fund allocation to be divided among States / UTs it will be done by giving :
- A) 50% weightage to the ratio of urban population in each State / UT to the total urban population, and
- B) 50% weightage to the ratio of number of statutory towns in each State / UT to the total number of statutory towns.

*Both ratios shall use Census 2011 data. Details of distribution of Project Fund across States / UTs are at Annexure III.*

10.3.3. The **Performance Grant** specified in 10.3.1(ii) above shall be kept with the SBM National Mission Directorate as Performance Grant and released as per the criteria mentioned below for rewarding performing states. The release of the performance grant shall be based on a Performance Matrix and Third Party Evaluation by the Independent Project Review & Monitoring Agency (IPRMA) on the following outcomes:

- a. Elimination of open defecation
- b. Conversion of insanitary latrines into pour-flush latrines
- c. Eradication of manual scavenging
- d. Prevention of pollution of water sources
- e. Ensuring cleanliness and hygiene in public places
- f. Awareness creation
- g. Capacity building

The National Advisory & Review Committee (NARC) at the M/o UD may also design other relevant criteria for the release of these funds and shall take a final view regarding the release of this grant keeping in view the progress made and circumstances of each State. This will not be applicable in the first installment. No withholding of 20% shall be done while releasing the first installment to the states.

#### **10.4. Disbursal of funds to States / UTs and ULBs**

10.4.1. States / UTs will submit a proposal for release of grant to the Central Government based on projections and authenticated targets with a Concept Note on State Urban Sanitation strategy in the format given in **Annexure IV**. This shall be submitted online to the SBM National Mission Directorate.

10.4.2. On acceptance of the State Government's proposal by the ministry, first installment of funds shall be disbursed to States / UTs in the following manner:

- i. 50% of the project fund shall be divided among states as per the formula mentioned at 10.3.2 (see also **Annexure III**).
- ii. 12% of Project funds released above shall be released as IEC and the Public Awareness component and,



- iii. 3% of the Project funds released above shall be released or the Capacity Building and A&OE funds.
- iv. No withholding of 20% shall be done on account of performance grant, while releasing the first installment to the states.

10.4.3. Subsequent installments (including for Capacity Building & IEC, and the Public Awareness and A&OE) shall be released on

- (i) Submission of the Utilization Certificate for 75% of the fund released as 1<sup>st</sup> installments and,
- (ii) Satisfactory physical and financial progress as per NARC criteria.

The quantum of subsequent installments will be based on actual demands and projections of expenditure for admissible components as per funding pattern of SBM.

10.4.4. Release of central contribution towards Grants / VGF by States/UTs for projects shall be in a manner described in paragraph 10.1 and 10.2 above.

10.4.5. At the end of the 2<sup>nd</sup> and 3<sup>rd</sup> quarters of each Financial Year, the use of allocated funds by States / UTs under the mission shall be reviewed by NARC, and NARC may reallocated funds from non-performing states to performing states based on the potential to utilize funds in a given financial year.

10.4.6. State governments shall evolve a suitable mechanism to release funds along with state share to ULBs within 30 days of release of the central share by M/o UD. Interest at the rate specified by the M/o Finance from time-to-time shall be levied on the State for any delay in release of funds to ULBs beyond 30 days. This will be implemented by appropriate deductions from the state's next installment of fund release under the mission.

**10.5. Sanction of projects (DPRs)**

10.5.1. Projects will be sanctioned by state government (HPEC) or ULBs as prescribed in these guidelines. This is specified for each for each component of SBM in these guidelines.

10.5.2. Only new projects will be considered under the Mission and it will be ensured that there is no duplication. Projects will be considered as "new" if they are not projects already sanctioned and ongoing under state and central schemes and externally-aided programmes.

34

10.5.3. Wherever Detailed Project Reports (DPRs) are to be prepared for project sanction, fund release and monitoring, the cost of DPRs for the projects under the Mission shall be reimbursed subject to norms set-up by the NARC.

10.5.4. The State High Powered Committee (HPC) will authorize institutes of national repute for appraisal of DPRs for the technical and economic appraisal of DPRs for projects recommended by ULBs. The cost of DPR appraisal by these institutes shall be an admissible component under administrative costs, subject to norms as approved by MoUD.

## 11. Mission Management Structure Swachh Bharat Mission (SBM)

Urban will have a three-tier mission management structure as follows:

### 11.1 National Level

11.1.1. A **National Advisory and Review Committee (NARC)** headed by the Secretary, M/o UD, and comprising representatives of relevant line ministries will be notified by the M/o UD. NARC will meet as per the requirements, but will meet at least once in three months. The functions of NARC will be:

- i. Overall monitoring and supervision of SBM (Urban)
- ii. Advise the States / UTs to explore avenues for innovative resource mobilization of private financing and leveraging land for PPP in sanitation projects.
- iii. Approve installments and release of installment of funds for states / UTs by Central Government under the mission.
- iv. Develop and modify performance matrix and criteria for the release of performance grants to States / UTs as specified in paragraph 10.3.3.
- v. Monitor outcomes and performance of projects sanctioned under SBM (Urban)
- vi. NARC may delegate, as it considers appropriate, some of the functions within prescribed limits, to the National Mission Director (NMD) of the SBM National Mission Directorate to ensure speedy implementation of the mission
- vii. Any other issue which may be referred to it by the Government

11.1.2. The **SBM National Mission Directorate** will be headed by a National Mission Director (NMD) who will not be below the rank of Joint Secretary to the Government of India.

- i. The NMD will be the overall in-charge of all activities related to SBM (Urban). NMD will be supported by a suitable team of officers at the

National Mission Directorate and will be Member-Secretary of NARC for all matters.

- ii. The Mission Directorate shall be supported by a dedicated Project Management Unit (PMU) with 10-12 experts and support staff mainly on an outsourced basis. The PMU shall cover 4 verticals – Programme management, IEC & Media, Information Technology, and Monitoring & Evaluation.
- iii. The SBM National Mission Directorate will formulate a framework for support structure for the State Mission Directorates and issue appropriate guidelines / advisories to states from time-to-time.

## 11.2. State level

11.2.1. A **High Powered Committee (HPC)** under the chairpersonship of the State's Chief Secretary, and with members drawn from concerned departments (including a MoUD representative) shall be responsible for the management of SBM (Urban) at the State / UT level. The functions of the SLMRC will include:

- i. Preparation, approval, and online publishing of the State Sanitation Strategy (SSS) for the respective state and City Sanitation Plan (CSP) for all cities covered under SBM (Urban), if not already done.
- ii. Finalisation of the Concept Note on the Urban Sanitation Situation before submission to the SBM National Mission Directorate
- iii. Empanel consultants of repute and experience for:
  - a. Preparation of DPRs under SBM
  - b. Conducting independent review and monitoring during execution of projects
- iv. Empanel reputed Institutes like IITs, NIT's, State Technical Universities etc. for appraisal of DPRs.
- v. Sanction projects relating to Solid Waste Management recommended by the ULBs.
- vi. Plan for additional resource mobilization .
- vii. Plan for fund flow in the short, medium and long term
- viii. Recommend proposals for release of installments of funds for projects under the mission
- ix. Monitor outcome and O&M arrangements of projects sanctioned and completed under the mission



- x. Review the progress of Capacity Building, IEC, and Public Awareness activities under the mission and approve their annual action plan.
- xi. Address violation of norms and conditions
- xii. Ensure convergence of action for sanitation in the state and bring about inter-departmental coordination for this purpose as and when required.
- xiii. Ensure timely audits of funds released and review the "Action Taken Reports" on various Audit reports of the mission and other similar reports
- xiv. Review legal issues, if any
- xv. Take up any other matter relevant for the efficient implementation of the mission, or matters referred to it by the SBM National Mission Directorate

11.2.2. The **SBM State Mission Directorate** will be located within the Urban Development Department (UDD) in the State / UT.

- i. The SBM State Mission Directorate will be headed by a State Mission Director (SMD) of appropriate seniority. The SMD will also function as Member-Secretary to the State Level HPC.
- ii. The SMD will create / notify a uniform structure across the state for the planning, designing, project preparation, appraisal, sanction and implementation of sanctioned projects under the mission at the ULB level. This shall be done keeping in mind the advisories issued by the National Mission Directorate from time-to-time.
- iii. The Mission Directorate shall be supported by a dedicated Project Management Unit (PMU) on an outsourced basis.

### 11.3. ULB level

The SBM is envisaged as People's movement (Jana Andolan) for ensuring hygiene, waste management and sanitation across the country. It is therefore essential that in its implementation the ULBs elicit the active participation of the Ward Committees, Area Sabhas, Resident Welfare Associations, NGOs and Civil Society Groups.

**12. Monitoring & Evaluation (M&E)**

12.1. States / UTs will be required to send in Monthly Progress Reports (MPRs) / Quarterly Progress Reports (QPRs) in prescribed formats with regard to targets and achievements. Apart from these, the Mission Directorate may prescribe other reports that may be considered appropriate from time to time. Given the scale of the mission, a comprehensive and robust IT enabled MIS will be established for tracking of targets and achievements. States / UTs will be required to submit progress reports online once this MIS is operational.

12.2. Monitoring activities will include, but not be limited to, third party evaluation, impact evaluation studies, etc. The evaluation of the mission will be undertaken during the course of its implementation to effect mid-term correction and align the mission to achieve its objectives

12.3. A **District Level Review and Monitoring Committee (DLRMC)** will be constituted with a view to fulfill the objective of ensuring satisfactory monitoring of projects under the Chairpersonship of a Member of Parliament. Detailed guidelines for this purpose will be issued separately by the SBM National Mission Directorate.

**13. Logo and Tag line**

The Logo and Tagline for the SBM (Urban) is given in **Annexure V**. This shall be displayed prominently on all projects and literature/publications under the mission.

\*\*\*

### Annexure I: Targets and definitions under SBM (Urban)

(Definitions reproduced from "House & Household Series Tables, Census of India 2011)

#### Targets under SBM (Urban)

For the purpose of SBM (Urban), the following action will have to be taken:

S. No.	Objective	Action under SBM (Urban) (Targets)	Census 2011 definition
i.	Elimination of open defecation	<ul style="list-style-type: none"> <li>80% urban households defecating in the open to be targeted for construction of household toilets</li> </ul>	No latrine within premises – open
ii.		<ul style="list-style-type: none"> <li>20% urban households defecating in the open to be targeted for construction of community toilets</li> </ul>	No latrine within premises – open
iii.		<ul style="list-style-type: none"> <li>Construction of public toilets for floating population (presumed at 5% of total urban population)</li> </ul>	Total urban population
iv.	Conversion of insanitary latrines into sanitary latrines	<ul style="list-style-type: none"> <li>100% of urban households having insanitary latrines to be targeted for construction of household toilets</li> </ul>	<ul style="list-style-type: none"> <li>Night soil disposed into open drain</li> <li>Service latrine with night soil removed by humans</li> <li>Service latrine with night soil serviced by animals</li> </ul>
v.	Conversion of single pit latrines	<ul style="list-style-type: none"> <li>60% of urban households having</li> </ul>	<ul style="list-style-type: none"> <li>Pit latrines with slab</li> <li>Pit latrines with</li> </ul>



S. No.	Objective	Action under SBM (Urban) (Targets)	Census 2011 definition
		pit latrines	ventilated improved pit • Pit latrines without slab / open pit
vi.	Solid Waste management	80% of the urban population to be covered by SWM services (allowing for a 2% increase year on year)	• Total urban population

**Definition of Types of latrines under Census 2011**

As per the Census of India 2011, the following various types of latrine facilities were surveyed:

1. Flush / pour flush latrine connected to piped sewer system: If a pour flush latrine is connected to a system of sewer pipes that collect both human excreta and waste water and removed them from the household environment
  2. Flush / pour flush latrine connected septic tank: If a pour flush latrine is connected to a septic tank that collects both human excreta and wastewater and removes them from the household environment
  3. Flush / pour flush latrine connected other system: If the pour or pour-flush latrine is connected to any system other than a piped sewer system or septic tank e.g. excreta and waste water gets flushed into the street, yard / plot, drainage ditch or any other location
  4. Pit latrines\*: defecation into pits dug into the ground for reception of night soil directly without flushing.
    - a. Pit latrine with slab: A pit latrine with a squatting slab or platform or set firmly supported on all sides, and raised above the surrounding ground level to prevent surface water from entering the pit, and easy to clean.
    - b. Pit latrine with ventilated improved pit: Pit latrines with slabs that are ventilated by a pipe extending above the latrine roof and the open end of the vent pipe is covered with mesh or fly-proof net
    - c. Pit latrine without slab / open pit: Pit latrines without a squatting slab or platform or seat
- \*Census 2011 does not distinguish between single pit and twin pit latrines. However for SBM single pit latrines will be considered insanitary and shall be converted. Definition of twin pit latrine see Annexure II.
5. Night soil disposed into open drain: Where a latrine facility may exist, but the excreta and waste water is disposed directly into an open drain

6. Service latrine: where human excreta is collected in a bucket, or other container, or even allowed to collect in the open
  - a. With night soil removed by humans: where the human excreta is removed physically by human beings
  - b. With night soil serviced by animals: where the human excreta is removed physically by animals
  
7. No latrine within premises – public latrine: Households have no latrines within the premises of the dwelling unit and use an available public latrine
  
8. No latrine within premises – open: Households have no latrine within the premises of the dwelling unit and defecate in the open in areas such as open fields, bushes, rivers, streams, railway tracks, etc.
  
9. Insanitary latrine means a latrine which requires human excreta to be cleaned or otherwise handled manually, either in situ or an open drain or pit into which the excreta is discharged or flushed out, before the excreta fully decomposes in such manner as may be prescribed.(Chapter I Section 2(i)(e) The Prohibition of employment as manual scavengers & their Rehabilitation Act,2013)

The Census of India 2011 defines **two broad kinds of urban areas** as follows:

- i. **Statutory towns** are urban areas defined by administrative units that have been defined by 'statute' as urban such as municipal corporations, municipalities, cantonment boards, notified town area committees, town panchayats, or nagar palikas; and
- ii. **Census Towns**: All administrative units satisfying the following criteria: (i) it should have a minimum population of 5,000 persons; (ii) at least 75% of the male main working population should have been engaged in non-agricultural pursuits; and (iii) it should have a density of population of at least 400 persons per km<sup>2</sup> (1,000 per mile<sup>2</sup>)

## Annexure II: Technical options for toilets under SBM (Urban)

This note explains the technical options for toilets that are recommended under the Swachh Bharat Mission (SBM) Urban.

### **On-Site Sanitation (OSS) vs. Underground Sewerage**

Wherever a sewerage system is available within 30m from the proposed individual household, community or public toilets only the superstructure (i.e. toilets) may be constructed under SBM and connected to the existing sewerage system. No construction of treatment units such as twin pits, septic tank, bio-digester or bio- tank shall be allowed.

### **Features of OSS Systems**

When sewage is collected, treated and/or disposed off at, or near the point of generation, without the use of an underground sewerage system, the system is called "on-site sanitation" (OSS) system. OSS systems are sanitation facilities provided for the use of individual households, community and the floating population. There are a number of situations when an underground sewerage system may not be feasible or desirable. For example, for smaller cities where construction of sewerage infrastructure may be expensive, or those cities that are in hilly areas or in undulating terrain where it may not be practical to construct a sewer network, or even in many cities that have grown organically and where not all households are connected to the existing sewerage network.

OSS systems consists of two main structures, the toilet (superstructure, including the pan and water closet) and the treatment unit. OSS retains waste in the vicinity of the toilet either in a pit, tank or vault. The treatment ranges from a basic sanitary facility such as twin-pit latrines, to a simple type of treatment system by combining a septic tank and a soak pit, or a bio-digester toilet (aerobic and anaerobic).

The following technological options for OSS are recommended under Swachh Bharat Mission (SBM) Urban for construction of Individual Household Latrines (IHL) / household toilets, group / shared latrines, and, community and public toilets

S. No.	OSS Option	Kind of Latrines				Application
		IHL	Shared Latrines	Community Toilets	Public Toilets	
1.	Twin-pit latrines / Leach Pits	✓				<ul style="list-style-type: none"> <li>In low- to medium-density areas, particularly peri-urban areas, where there is space to install pits and where the digested sludge can be applied to</li> </ul>



S. No.	OSS Option	Kind of Latrines				Application
		IHL	Shared Latrines	Community Toilets	Public Toilets	
						<p>local fields and/or gardens as a fertilizer and soil conditioner</p> <ul style="list-style-type: none"> <li>Where water use is in the range 30–50 liters per capita per day depending upon the characteristics of the soil or groundwater level</li> </ul>
2.	Septic Tank System with soak pit	✓	✓	✓	✓	<ul style="list-style-type: none"> <li>Septic tanks are widely used to provide partial treatment of wastewater from individual homes, household clusters or institutional buildings where there is no sewerage network.</li> <li>For soak pits to function, soil conditions must be suitable for infiltration of effluent from septic tanks</li> </ul>
3.	Bio-digester toilets (Anaerobic – developed by DRDO)	✓	✓	✓	✓	<ul style="list-style-type: none"> <li>Widely used to provide 80% treatment of wastewater from IHL, household clusters or institutional buildings where there is no sewerage network.</li> <li>The effluent should be passed through a reed bed or soak pit before discharge.</li> <li>For soak pits to function, soil conditions must be suitable for infiltration of effluent from septic tanks</li> </ul>
4.	Aerobic BioTank	✓	✓	✓	✓	<ul style="list-style-type: none"> <li>Widely used to provide 100% treatment of</li> </ul>

S. No.	OSS Option	Kind of Latrines				Application
		IHL	Shared Latrines	Community Toilets	Public Toilets	
						<p>wastewater from IHL, clusters of houses or institutional building where there is no sewerage networks. The effluent can be directly discharged since it is completely safe;</p> <ul style="list-style-type: none"> <li>• Chlorination is followed after treatment</li> </ul>

### **Technical features and specification for toilets under SBM (Urban)**

The details of technical features and specifications for toilets are given as under. The costs are simply estimates at this point of time and should be verified at the time of selection and installation of the technology.

#### I. Twin-Pit Latrine

<b>Description</b>	<p>It consists of superstructure (Toilet) and treatment units (two chambers). The two underground chambers (pits) are provided to hold fecal sludge. These are normally offset from the toilet and should be at least 1 meter apart. A single pipe leads from the toilet to a small diversion chamber, from which separate pipes lead to the two underground chambers. The pits should be lined with open-jointed brickwork. Each pit should be designed to hold at least 12 months accumulation of fecal sludge.</p> <p>Wastewater is discharged to one chamber until it is full of fecal sludge. Discharge is then switched to the second chamber. Just before the second chamber is full of fecal sludge, the contents of the first pit are dug out. During the time of storage, digestion should ensure that it is odorless and free of pathogens.</p>
<b>O&amp;M Requirements</b>	<p>The pits must be used alternately and the diversion chamber must be accessible so that flow can be diverted between chambers. Wastewater should never be diverted back to the first chamber before digested sludge has been removed from it.</p> <p>Responsibility for O&amp;M of the twin-pit latrine rests primarily with the householder, who needs to ensure that the pits are used in the correct sequence and are emptied at the appropriate time.</p>

	However, ULB utility or private contractors are required for emptying and to ensure safe disposal of septage at a treatment plant.																					
<b>Additional Infrastructure / treatment requirements</b>	If digested material cannot be used in local fields and gardens, provision will have to be made for transportation to areas outside the city for reuse on agricultural land.																					
<b>Limitations</b>	<ul style="list-style-type: none"> <li>Households may not understand the system and as a result may not use the pits alternately, or may omit to rest the filled pit at least for one year so that the contents degrade and become harmless.</li> <li>Explanation of the operation and maintenance requirements is therefore essential at the time of installation.</li> <li>Water may percolate through the soil surrounding the pit and pollute groundwater, which is a potential problem if water is used for drinking.</li> </ul>																					
<b>Specifications</b>	<p>(a) <b>Size options for Toilet/ Super Structure</b> (as shown in Fig.1):</p> <p>a. 750 mm x 900 mm x 1900mm; or</p> <p>b. 800 mm x 1000 mm x 1900 mm</p> <p>(b) <b>Material</b> – Brick work (as per Fig. 1) / FRP/ Pre-cast Cylindrical Unit</p> <p>(c) <b>Minimum Land Requirement</b> – 40 Sq. ft. - 60 Sq. ft. (depending upon the location of superstructure and distance between two pits)</p> <p>(d) <b>Size of Pits</b> is shown in Table -1 below</p> <table border="1"> <thead> <tr> <th></th> <th colspan="2">5 users*</th> <th colspan="2">10 users**</th> <th colspan="2">15 users***</th> </tr> <tr> <th></th> <th>Dia</th> <th>Depth (A)</th> <th>Dia</th> <th>Depth (A)</th> <th>Dia</th> <th>Depth (A)</th> </tr> </thead> <tbody> <tr> <td><b>Pit size</b></td> <td>900</td> <td>1000</td> <td>1100</td> <td>1300</td> <td>1300</td> <td>1400</td> </tr> </tbody> </table> <p>*- only for IHL  ** - Group household toilets  The specification for pits given at Fig 2 may be referred to.</p>		5 users*		10 users**		15 users***			Dia	Depth (A)	Dia	Depth (A)	Dia	Depth (A)	<b>Pit size</b>	900	1000	1100	1300	1300	1400
	5 users*		10 users**		15 users***																	
	Dia	Depth (A)	Dia	Depth (A)	Dia	Depth (A)																
<b>Pit size</b>	900	1000	1100	1300	1300	1400																
<b>Cost (for 5 users)</b>	Tentative cost varies from Rs. 15,000/- to Rs. 20,000/- depending upon the construction material.																					

<b>DESIGN OF PITS UNDER DIFFERENT CONDITIONS</b>	
<b>Normal conditions</b>	A typical pour flush latrine with circular pits for normal conditions is shown in <b>Figure 2</b> . In rocky strata with a soil layer in between, the leach pits can be designed on the same principle as those for low subsoil water level and taking the long-term infiltrative capacity as 20 l/m <sup>2</sup> /d. However, in rocks with fissures, chalk formations, or old root channels, pollution can flow for very long distances; hence these conditions demand careful investigation and adoption of adequate pollution safeguards. Pits in



	<p>black cotton soil should be designed taking infiltrative rate of 10 l/m<sup>2</sup>/d.</p> <p>A vertical fill (envelope) of 300 mm in width with sand, gravel or ballast of small sizes should be provided all round the pit outside the pit lining in rocky strata with fissures and in black cotton soil.</p>
<b>In water-logged areas</b>	The pit top should be raised by 300 mm above the likely level of water above ground level at the time of water logging. Earth should then be filled well compacted all-round the pits up to 1.0 m distance from the pit and up to its top. The raising of the pit will necessitate the raising of latrine floor also. A typical pour flush latrine in water-logged areas is shown in <b>Figure 3</b> .
<b>In high subsoil water level</b>	Where the subsoil water level rises to less than 300 mm below ground level, the top of the pits should be raised by 300 mm above the likely subsoil water level and earth should be filled all round the pits and latrine floor raised as stated above. A typical pour flush latrine with leach pits in high subsoil water level is shown in <b>Figure 4</b> .
<b>Where space is a constraint</b>	Where circular pits of standard sizes cannot be constructed due to space constraints, deeper pit with small diameter (not less than 750 mm), or combined oval, square or rectangular pits divided into two equal compartments by a partition wall may be provided. In case of combined pits and the partition wall should not have holes. The partition wall should go 225 mm deeper than the pit lining and plastered on both sides with cement mortar. A typical pour flush latrine with combined pits is shown in <b>Figure 5</b> .

## II. Septic Tank

<b>Description</b>	A septic tank is a buried chamber that collects, stores and treats the wastewater under anaerobic conditions. Effluent from septic tanks should be discharged into a soak pit. A well-managed septic tank will remove about 50 to 60 % of the biological load in the wastewater
<b>Mode of operation</b>	Solids settle in the tank and digest anaerobically. This reduces sludge volume and enables wastewater to infiltrate into the ground without clogging the leaching system. Sludge settles in the tank and digests anaerobically over time, releasing methane and other gases.
<b>O&amp;M Requirements</b>	Septage must be removed from septic tanks at least once every 2 or 3 years and transported off-site for treatment prior to disposal. Municipal utility or private contractors are required for desludging of septic tanks and to ensure safe disposal of septage at a treatment plant. However the responsibility for O&M of the septic tank itself lies with the owner of the property
<b>Limitations</b>	<ul style="list-style-type: none"> <li>• Cost and space requirements for the soak pit.</li> <li>• Though septic tanks are designed for receiving black water, they often receive both black and grey water. As a result, the retention time in the septic tank is insufficient and the soak pit becomes hydraulically overloaded. This means that the septic tanks need to be de-sludged regularly</li> </ul>
<b>Specifications</b>	<p>(a) <b>Size options for toilet / super structure as shown in Fig. 1</b></p> <ul style="list-style-type: none"> <li>• 750 mm x 900 mm x 1900mm or</li> <li>• 800 mm x 1000 mm x 1900 mm</li> </ul> <p>(b) <b>Material</b> – Brick work (as per Fig. 1) / FRP / Pre-cast Cylindrical Unit</p> <p>(c) <b>Minimum Land requirement</b> - 40 Sq. ft. to 50 Sq. ft. (depending upon the location of superstructure)</p> <p>(d) <b>Soak-pit size</b> - The seepage pit may be of any suitable shape with the least cross-sectional dimension of 0.90 m and not less than 1 m in depth below the invert level of the inlet pipe. The construction shall be of perforated brickwork</p>

(e) Recommended sizes of septic tanks for households (up to 20 users – group / shared toilets) is given in Table 2 below:

No. of users	Length (m)	Breadth (m)	Liquid depth (m) (Cleaning interval of)	
			2 years	3 years
5*	1.5	0.75	1.0	1.05
10**	2.0	0.90	1.0	1.4
15**	2.0	0.90	1.3	2.00
20**	2.3	1.10	1.3	1.80

\*- only for IHL  
\*\*- Group household toilets

Note 1: The capacities are recommended on the assumption that discharge from only WC will be treated in the septic tank  
Note 2: A provision of 300 mm should be made for free board.  
Note 3: The sizes of septic tank are based on certain assumption on peak discharges, as estimated in IS: 2470 (part 1) and while choosing the size of septic tank exact calculations shall be made.

Cost (for 5 users)	<ul style="list-style-type: none"> <li>Tentative cost varies from Rs. 25,000/- to Rs. 30,000/- depending upon the construction material (toilet and septic tank).</li> <li>Pre fabricated septic tanks are available at lower cost in the market, which also may be explored to speed up the implementation.</li> </ul>
--------------------	---

### III. Biodigester Toilet (Developed by DRDO)

Description	<p>A bio-digester toilet is an anaerobic multi-compartment tank with inoculum (anaerobic bacteria) which digests organic material biologically. The details of bio-digester toilets are shown in Figure 7. This system converts faecal waste into usable water and gases in an eco-friendly manner.</p> <p>It can be connected to the toilet or a series of toilets. The toilet can be a superstructure fixed on the bio-digester or a separate unit. Bio-digester has an inlet, an outlet and a gas pipe.</p> <p>The tank has two components, namely, anaerobic microbial inoculum (seed bacteria) and specially designed fermentation tank. The tank can be made out of Stainless steel, Mild steel, FRP or concrete. Semi-treated water from bio-digester tank is needed to be further disposed into a soak pit or a reed bed arrangement for its treatment to acceptable levels of discharge.</p>
Advantages	<ul style="list-style-type: none"> <li>As there is no sludge formation, there is no need for de-sludging and treatment. It is therefore more economical in the long-term as it conserves water and has minimum O&amp;M</li> <li>Night soil degradation, occurs through microbial reaction which converts it into bio gas and odorless water.</li> <li>Technology is environmental friendly, maintenance free and efficient without depending on conventional energy sources.</li> <li>Permits use of toilet cleansing agents.</li> <li>Suitable for mobile and stationary platforms.</li> <li>Lifelong usage bio-digester tank does not need recharging, re-shifting or maintenance.</li> <li>Costs lesser than the conventional toilets.</li> <li>Easy to transport and install.</li> </ul>



	<ul style="list-style-type: none"> <li>• One-third to one-fourth capacity of septic tank</li> <li>• Space requirement is less.</li> </ul>																			
<b>Limitations</b>	•																			
<b>Specifications</b>	<p><b>Toilet Superstructure</b></p> <p>(a) Size of Toilet / super structure – as shown in Fig. 1</p> <ul style="list-style-type: none"> <li>• 750 mm x 900 mm x 1900mm or</li> <li>• 800 mm x 1000 mm x 1900 mm</li> </ul> <p>(b) Material – Brick work (as per Fig. 1) / FRP/ Pre cast Cylindrical Unit</p> <p><b>Bio tank</b></p> <p>(a) Land requirement – 25 sq. ft.</p> <p>(b) Tank internal dimensions – 1336 mm x 1036 mm x 900 mm</p> <p>(c) Diagonal partition wall of 8mm thickness (adequately stiffened by ribs)</p> <p>(d) Tank is buried 600mm deep and anchored by 300mm long stainless steel (SS316) anchor bolts at corners</p> <p>(e) FRP tanks of 8mm thickness</p> <p>(f) Provision of water sealed outlet from the tank</p> <p>(g) For 5-6 users:</p> <ol style="list-style-type: none"> <li>Total capacity: 700 litres (1000 mmX700 mm and 1000 mm depth). Where space is a constraint the depth of the tank can be increased to 1.5 m</li> <li>Volume of anaerobic Compartment (30% of total capacity): 210 litres</li> <li>Tank may be constructed with masonry also.</li> </ol> <p><b>Table 3 - Volume of bio-digester tank for various user groups:</b></p> <table border="1"> <thead> <tr> <th>No. of users</th> <th>Size of bio-digester / bio-toilet</th> <th>Remarks</th> </tr> </thead> <tbody> <tr> <td>4-8 (Single family)</td> <td>0.7m<sup>3</sup> (FRP / RCC material)</td> <td>Individual</td> </tr> <tr> <td>8-15 (two families)</td> <td>1.2 m<sup>3</sup> (FRP / RCC material)</td> <td>Group / shared</td> </tr> <tr> <td>30-50</td> <td>3.2 m<sup>3</sup> (FRP / RCC material)</td> <td rowspan="4">Community</td> </tr> <tr> <td>100-120</td> <td>6.0 m<sup>3</sup> (FRP / RCC material)</td> </tr> <tr> <td>200-220</td> <td>12.0 m<sup>3</sup> (FRP / RCC material)</td> </tr> <tr> <td>500-600</td> <td>30.0 m<sup>3</sup> (FRP / RCC material)</td> </tr> </tbody> </table>	No. of users	Size of bio-digester / bio-toilet	Remarks	4-8 (Single family)	0.7m <sup>3</sup> (FRP / RCC material)	Individual	8-15 (two families)	1.2 m <sup>3</sup> (FRP / RCC material)	Group / shared	30-50	3.2 m <sup>3</sup> (FRP / RCC material)	Community	100-120	6.0 m <sup>3</sup> (FRP / RCC material)	200-220	12.0 m <sup>3</sup> (FRP / RCC material)	500-600	30.0 m <sup>3</sup> (FRP / RCC material)	
No. of users	Size of bio-digester / bio-toilet	Remarks																		
4-8 (Single family)	0.7m <sup>3</sup> (FRP / RCC material)	Individual																		
8-15 (two families)	1.2 m <sup>3</sup> (FRP / RCC material)	Group / shared																		
30-50	3.2 m <sup>3</sup> (FRP / RCC material)	Community																		
100-120	6.0 m <sup>3</sup> (FRP / RCC material)																			
200-220	12.0 m <sup>3</sup> (FRP / RCC material)																			
500-600	30.0 m <sup>3</sup> (FRP / RCC material)																			
<b>Cost Estimates</b>	<ul style="list-style-type: none"> <li>• Toilet cost between Rs. 12,000 and Rs. 15,000 depending on material of construction;</li> <li>• Bio-digester tank as per Table 4 below:</li> </ul> <table border="1"> <thead> <tr> <th rowspan="2">Bio-digester tank -&gt;</th> <th colspan="3">Material of construction</th> </tr> <tr> <th>Masonry</th> <th>Precast Cylindrical Unit</th> <th>Fiber reinforced plastic</th> </tr> </thead> <tbody> <tr> <td>No. of users / Capacity</td> <td></td> <td></td> <td></td> </tr> <tr> <td>5 to 7 users (700 Litre)</td> <td>17,100</td> <td>11,600</td> <td>22,000</td> </tr> <tr> <td>10 to 12 users (1000 Litre)*</td> <td>19,000</td> <td>13,600</td> <td>24,000</td> </tr> </tbody> </table> <p>*Group / Shared toilets</p>	Bio-digester tank ->	Material of construction			Masonry	Precast Cylindrical Unit	Fiber reinforced plastic	No. of users / Capacity				5 to 7 users (700 Litre)	17,100	11,600	22,000	10 to 12 users (1000 Litre)*	19,000	13,600	24,000
Bio-digester tank ->	Material of construction																			
	Masonry	Precast Cylindrical Unit	Fiber reinforced plastic																	
No. of users / Capacity																				
5 to 7 users (700 Litre)	17,100	11,600	22,000																	
10 to 12 users (1000 Litre)*	19,000	13,600	24,000																	

#### IV. Bio Tank / Bio Toilets (Patented by private operators and approved by the Department of Science and Technology)

<b>Description</b>	This technology differs from that of the bio-digester toilets developed by DRDO since the process adopted is aerobic - which involves a different multi-strain of bacteria which breaks down the waste matter through oxidization. Bio-toilets consist of a purpose built multi-
--------------------	--



	<p>chambered bio-tank in which the waste is stored as shown in <b>Figure 8</b>. The movement of the waste is slowed down as the waste flows from one chamber to another by a special process in the Bio-tank such that the multi-strain bio-media present in the tank can digest the waste and convert it fully into non-toxic neutral water. This water then passes through the last chamber for disinfection. Here water is treated with Chlorine where the majority of the germs are killed. The resultant water is free from all sorts of E-coli and fecal coliforms.</p> <p>The bricks and mortar Bio-tank is described in the last diagramme of Figure 8. The superstructure is made of bricks and mortar. These are available in both flush and non-flush models.</p>
Advantages	<ul style="list-style-type: none"> <li>• Aerobic bacteria are very efficient in breaking down organic waste and the waste is decomposed into water by the bacteria within 24 hours. The end products of aerobic degradation are carbon dioxide (CO<sub>2</sub>) and water (H<sub>2</sub>O).</li> <li>• The aerobic pathway also releases a substantial amount of energy.</li> <li>• The Bio-toilet is available in both, portable as well as fixed models. The advantage of the portable model is that it can be shifted from one location to another as and when required, and the module can be assembled and disassembled easily.</li> <li>• The Bio-toilet eliminates the need for any periodic sludge removal.</li> </ul>
Limitations	<ul style="list-style-type: none"> <li>• The bacteria functions best in temperatures between 4 and 55 degrees centigrade</li> <li>• Bio-toilets need proper bacteria inoculation periodically depending on the usage at particular sites. An in-depth understanding of the operation and use of toilets in a given area must be undertaken BEFORE choosing bio-toilets as a solution. Attention must be given to O&amp;M, especially in dense urban settlements where chances of blockage of bio-toilets increase, making it dysfunctional over a period of time if the inoculation is not done in time.</li> <li>• Phenyl/ Harpic or any strong detergent/acid and bleaching powder should not be used to clean the pan. Only herbal / ayurvedic cleaning agents should be used.</li> <li>• Chlorine dose is necessary for disinfection.</li> </ul>
O&M	Responsibility of cleaning the toilet / superstructure is with the owner of the household in the case of IHLs / shared latrines and with the ULB in the case of community / public toilets.
Specifications	<p>(a) <b>Size of Toilet/ Super Structure as shown in Fig. 1 –</b></p> <ul style="list-style-type: none"> <li>• 750 mm x 900 mm x 1900mm or</li> <li>• 800 mm x 1000 mm x 1900 mm</li> </ul>

	<p>(b) <b>Material</b> – Bricks and Mortar walls of Bio Digester tank and Superstructure, PCC tank floor, RCC toilet floor, PVC Door and Frame, RCC/PVC/GI sheet Toilet Roof.</p> <p>(c) <b>The Bio-toilet system consists of:</b></p> <ul style="list-style-type: none"> <li>• Bio digester Tank(Bricks &amp; Mortar/FRP/Steel),</li> <li>• Superstructure(Bricks &amp; Mortar/FRP)</li> <li>• Indian Pan/WC</li> <li>• Size: 4 feet x 4 feet tank base, 4 feet tank height, 6 feet superstructure height.</li> <li>• Maximum usage recommended: 30 defecations/ day/ bio-toilet (no limit on urination)</li> </ul> <p>(d) <b>Land requirement</b> - 16 Sq. ft.</p>
<p><b>Cost Estimates</b></p>	<p>The tentative cost of bio-toilet including super structure is approximately Rs.20,000/- depending upon material of construction. The bio-toilets should be supplied by the manufacturers, and the O&amp;M for at least 5 years (including the feeding of inoculum in the periodicity needed) along with IEC (to train users for O&amp;M) by the manufacturer / supplier also should be built into the undertaking.</p>

**Norms & Specifications for Community and Public Toilets**

<p><b>Description</b></p>	<p>A <b>community toilet block</b> is a shared facility provided for a group of residents or an entire settlement. Community toilet blocks are used primarily in low-income informal settlements where space and/or land are constraints. Pour flush option is generally used in this kind of OSS systems. It is also advisable to provide facilities like washing, bathing, and a small incinerator in this block for the use of the community</p> <p><b>Public toilets</b> are provided for the floating population / general public in places such as markets, train stations or other public areas, where there is a considerable number of people passing by.</p>																																
<p><b>Septic tanks for public / community toilets</b></p>	<p>Recommended sizes of septic tanks for community/ public toilets (up to 300 users) is given below in Table 5.</p> <table border="1" data-bbox="430 1635 1380 1960"> <thead> <tr> <th rowspan="2">No. of users</th> <th rowspan="2">Length (m)</th> <th rowspan="2">Breadth (m)</th> <th colspan="2">Liquid depth (cleaning interval of)</th> </tr> <tr> <th>2 years</th> <th>3 years</th> </tr> </thead> <tbody> <tr> <td>50</td> <td>5.0</td> <td>2.00</td> <td>1.0</td> <td>1.24</td> </tr> <tr> <td>100</td> <td>7.5</td> <td>2.65</td> <td>1.0</td> <td>1.24</td> </tr> <tr> <td>150</td> <td>10.0</td> <td>3.00</td> <td>1.0</td> <td>1.24</td> </tr> <tr> <td>200</td> <td>12.0</td> <td>3.30</td> <td>1.0</td> <td>1.24</td> </tr> <tr> <td>300</td> <td>15.0</td> <td>4.00</td> <td>1.0</td> <td>1.24</td> </tr> </tbody> </table>	No. of users	Length (m)	Breadth (m)	Liquid depth (cleaning interval of)		2 years	3 years	50	5.0	2.00	1.0	1.24	100	7.5	2.65	1.0	1.24	150	10.0	3.00	1.0	1.24	200	12.0	3.30	1.0	1.24	300	15.0	4.00	1.0	1.24
No. of users	Length (m)				Breadth (m)	Liquid depth (cleaning interval of)																											
		2 years	3 years																														
50	5.0	2.00	1.0	1.24																													
100	7.5	2.65	1.0	1.24																													
150	10.0	3.00	1.0	1.24																													
200	12.0	3.30	1.0	1.24																													
300	15.0	4.00	1.0	1.24																													

	<p>Source: Manual on Sewerage and Sewage Treatment Systems, 2013 Part A Engineering</p> <p>Note 1: A provision of 300 mm should be made for free board.</p> <p>Note 2: The sizes of septic tanks are based on certain assumptions on peak discharges, as estimated in IS: 2470 (Part 1) and while choosing the size of septic tank exact calculations shall be made.</p> <p>Note 3: For population over 100, the tank may be divided into independent parallel chambers of maintenance and cleaning</p>			
<b>Community Toilet - Norms for toilet seats</b>	<ul style="list-style-type: none"> <li>• One seat for 35 men;</li> <li>• One seat for 25 women</li> <li>• Adequate bathing facilities</li> </ul>			
<b>Public Toilets - Norms for toilet seats</b>	Norms for toilet sets for public toilets are given in Table 6 below:			
	<b>S. No.</b>	<b>Sanitary Unit</b>	<b>For Male</b>	<b>For Female (A)</b>
	i.	Water Closet	One per 100 persons up to 400 persons; For over 400 persons, add at the rate of one per 250 persons or part thereof	Two for 100 persons up to 200 persons; over 200 persons, add at the rate of one per 100 persons or part thereof
	ii.	Ablution Taps	One in each W.C.	One in each W. C.
	iii.	Urinals	One for 50 persons or part thereof	Nil
iv.	Wash basins	One per W. C. and urinal provided	One per W. C. provided	
	<p>Source: Manual on Sewerage and Sewage Treatment Systems, 2013 Part A Engineering</p> <p>Note:</p> <p>i) It may be assumed that two-thirds of the number are males and one-third females</p> <p>ii) One water tap with drainage arrangements shall be provided for every 50 persons or part thereof in the vicinity of water closet and urinals.</p> <p>* At least 50% of female WCs may be Indian pan and 50% EWC</p> <p>iii) Separate seat may also be provided for trans-genders</p> <p>iv) Special arrangements may be made for physically challenged.</p>			
<b>Treatment units</b>	<ol style="list-style-type: none"> <li>1. Bio Digester with reed bed systems/ soak pits</li> <li>2. Bio Tank</li> <li>3. Septic Tank with Soak Pits</li> </ol>			
<b>Cost</b>	Tentative basic cost for community toilets is Rs. 65,000/- per seat and public toilets is Rs. 75,000/- per seat. However, the cost per seat would vary depending upon the construction material, quality of construction, type of treatment technology adopted and O&M for specified period etc. However the cost of toilet in bio-digester given by NBCC are as under.			



<b>Superstructure 5 Cubicle for 200 users</b>			
Pre Painted galvanized Sheets	Masonry	Cement Board	
Rs. 1,63,000.00/-	Rs.95,000.00/-	Rs. 80,000.00/-	
<b>Superstructure 10 Cubicle for 400 users</b>			
Pre Painted galvanized Sheets	Masonry	Cement Board	
Rs.3,26,000.00/-	Rs. 1,80,000.00/-	Rs. 1,60,000.00/-	
<b>Bio Digester Tank 10 KLD for every 200 users</b>			
Masonry			
Rs. 1,74,000.00/- per 200 user			
<b>Additional Infrastructure</b>	It must be ensured that adequate water supply arrangement shall be made for proper functioning and upkeep of toilets. Wherever possible, ULBs should ensure that public and community toilets are outfitted with solar panels for the generation of electricity to ensure uninterrupted power supply and bring down O&M costs.		
<b>Implementation Mode</b>	All toilets shall be constructed through PPP mode with inbuilt provision of O&M for at least a period of 5 years.		

For additional details the guidelines developed by NBCC can be downloaded. ([www.nbccindia.gov.in](http://www.nbccindia.gov.in))



Figure 2: Pour-flush latrine with circular pits  
 (Source: Manual on Sewerage and Sewage Treatment Systems, 2013, Part A: Engineering)

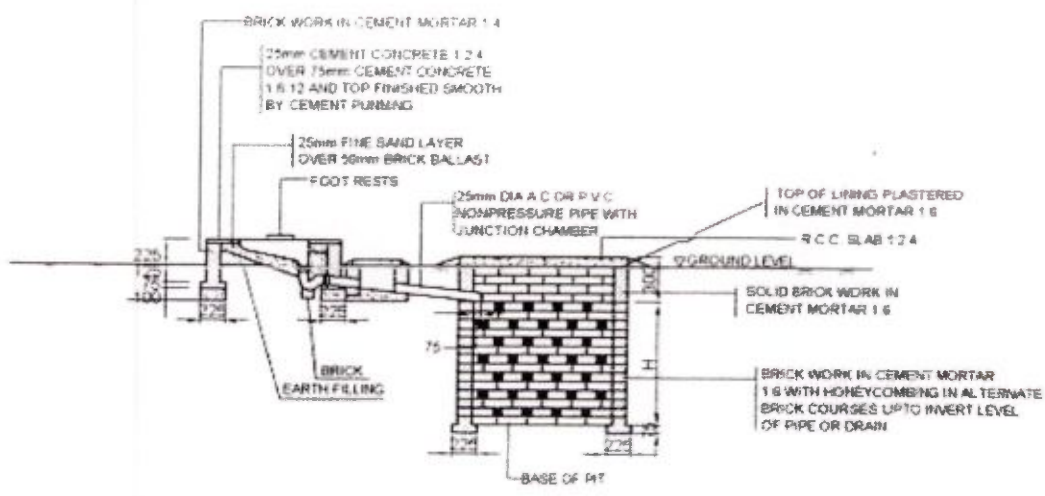

SECTION A B C

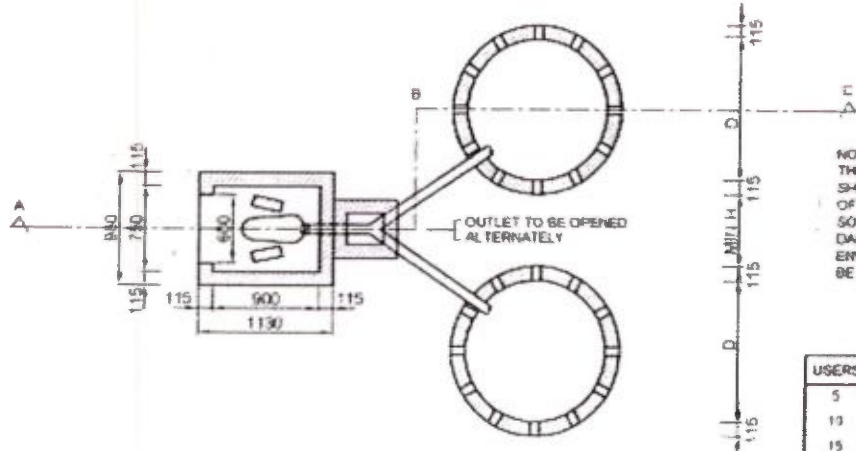

DRY PIT

USERS	D	H	T
5	800	550	50
13	1000	1050	50
15	1200	1100	60

PLAN











Figure 6: Typical sketch of two-compartment septic tank for 5 users

(Source: Manual on Sewerage and Sewage Treatment Systems, 2013, Part A: Engineering)

(Dimensions in mm)

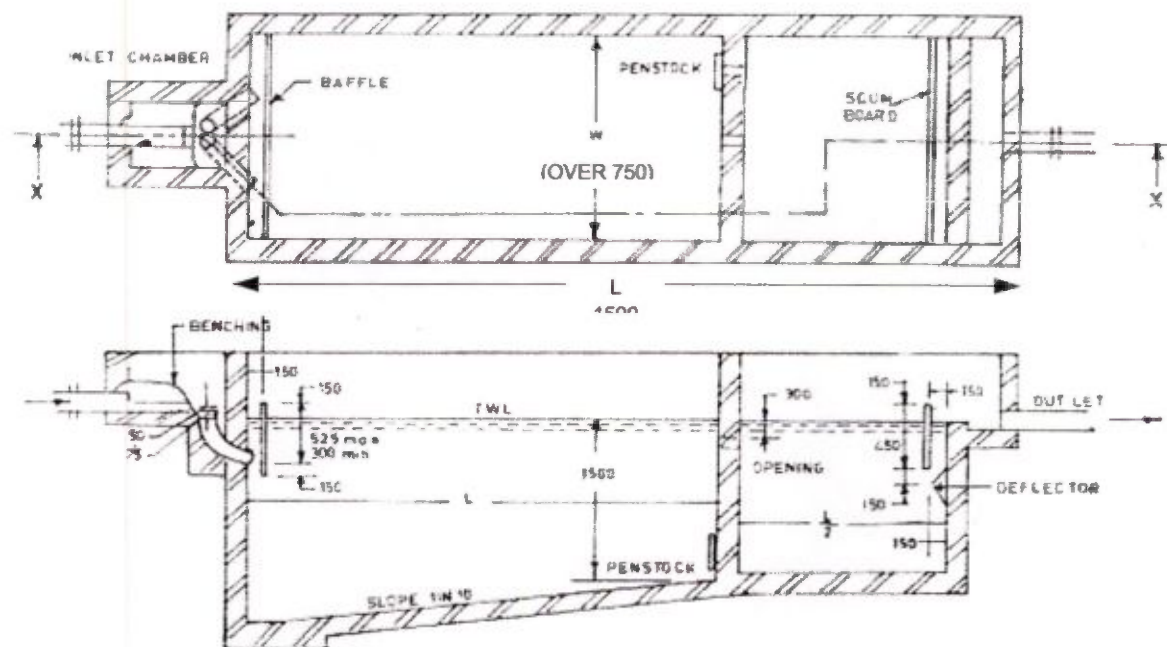

Figure 7: Details of bio-digester with reed bed

(Source: DRDO)

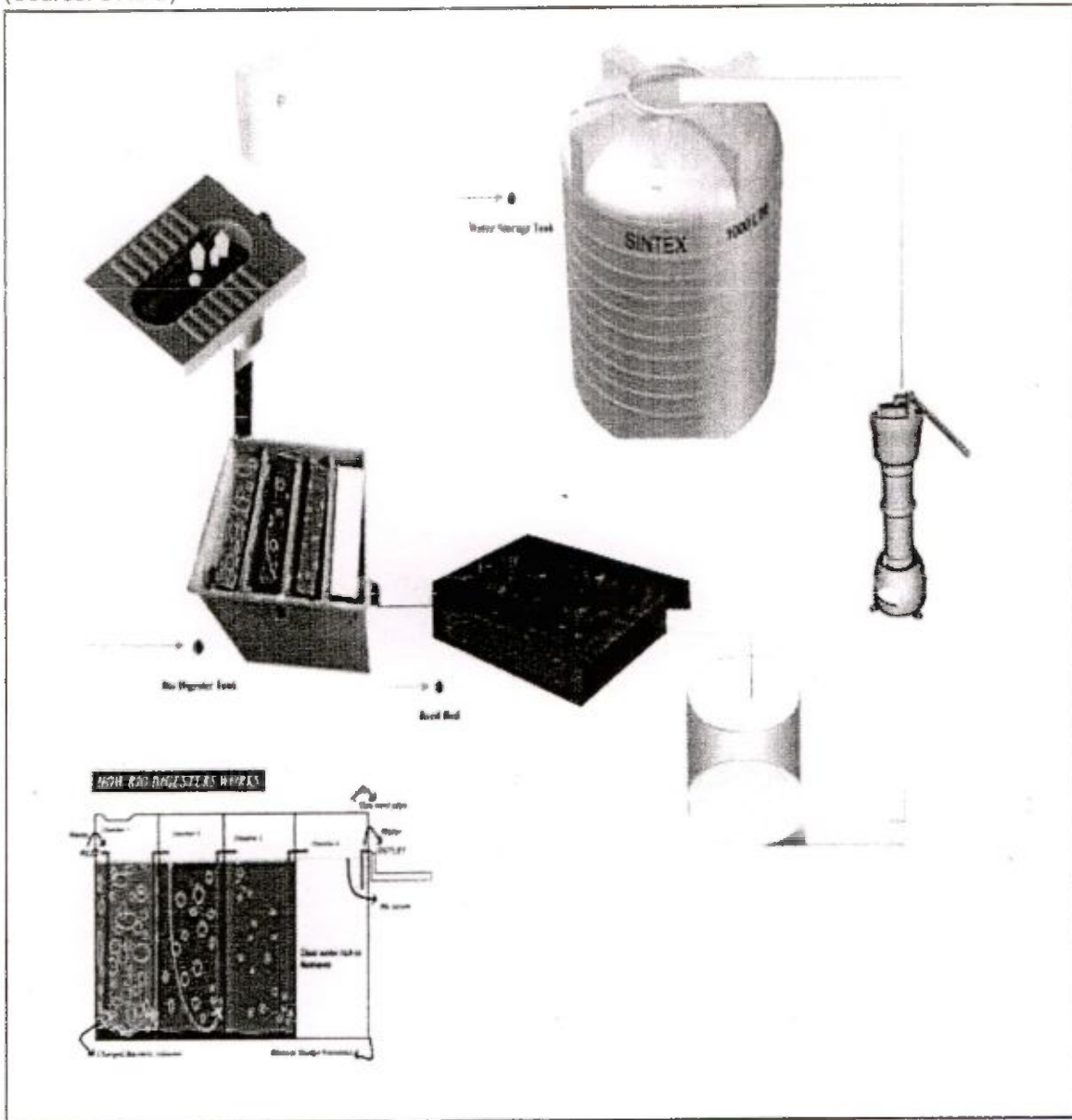
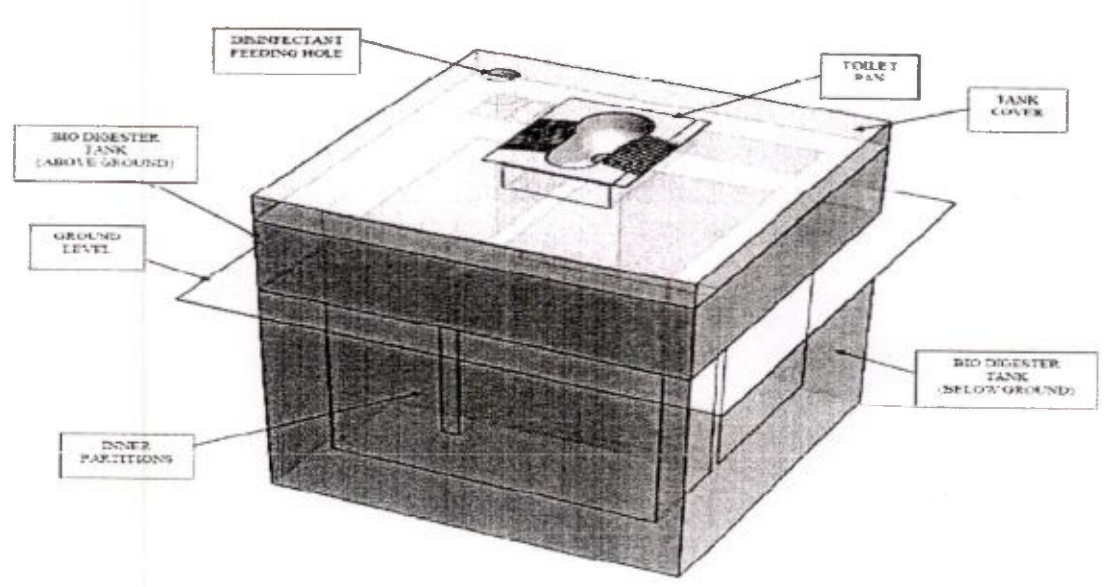
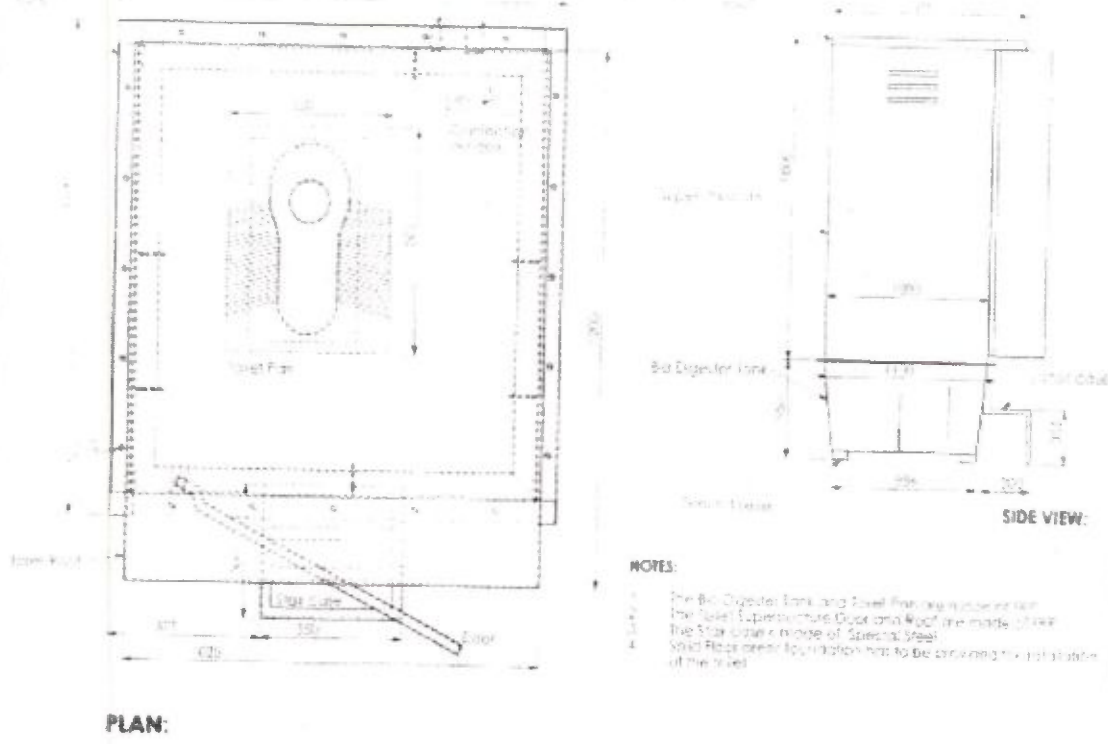

Figure 8: Details of Bio-Toilet

(Source: Private Agency)





8

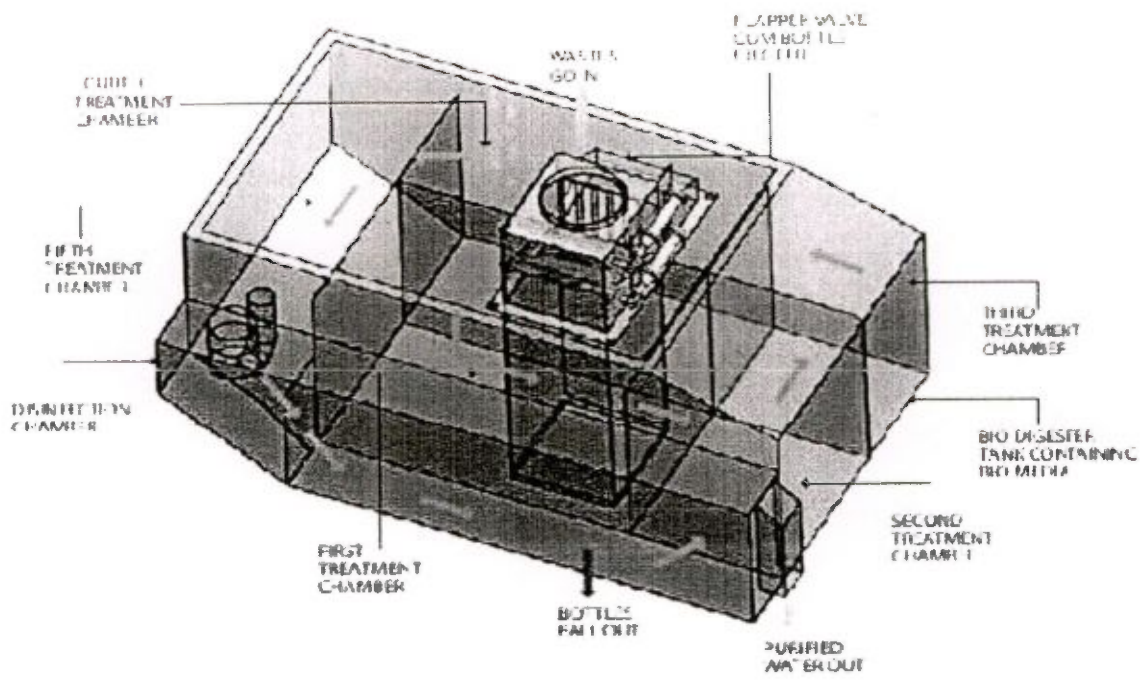

**Annexure III: Distribution of the Project Fund across States / UTs under SBM (Urban)**

States/UTs	POPULATION OF STATUTORY TOWNS		STATUTORY TOWNS		OPEN DEFECACTION		Fund Share * (%)
	Pop. (minus OG)	Population Share (%)	No.	ST Share %	HHs	HH Share %	
<b>All India</b>	<b>31,85,49,793</b>		<b>4,041</b>		<b>79,02,614</b>		
<b>NON-NE STATES</b>	<b>31,20,08,498</b>		<b>3,823</b>		<b>78,59,648</b>		
ANDAMAN & NICOBAR ISLANDS	1,08,058	0.03%	1	0.03%	1,209	0.02%	0.03%
ANDHRA PRADESH	2,30,04,396	7.37%	125	3.27%	5,81,673	7.40%	5.32%
BIHAR	1,12,41,824	3.60%	139	3.64%	5,45,409	6.95%	3.62%
CHANDIGARH	9,61,587	0.31%	1	0.03%	6,397	0.08%	0.17%
CHHATTISGARH	56,87,885	1.82%	168	4.39%	4,15,147	5.28%	3.11%
DADRA & NAGAR HAVELI	98,265	0.03%	1	0.03%	1,992	0.03%	0.03%
DAMAN & DIU	68,273	0.02%	2	0.05%	678	0.01%	0.04%
GOA	4,01,929	0.13%	14	0.37%	5,788	0.07%	0.25%
GUJARAT	2,31,88,334	7.43%	195	5.10%	3,88,836	4.95%	6.27%
HARYANA	78,61,917	2.52%	80	2.09%	1,28,059	1.63%	2.31%
HIMACHAL PRADESH	6,58,036	0.21%	56	1.46%	10,911	0.14%	0.84%
JAMMU & KASHMIR	29,40,098	0.94%	86	2.25%	44,501	0.57%	1.60%
JHARKHAND	53,05,359	1.70%	40	1.05%	2,54,374	3.24%	1.37%
KARNATAKA	2,21,63,498	7.10%	220	5.75%	5,34,829	6.80%	6.43%
KERALA	52,47,614	1.68%	59	1.54%	18,429	0.23%	1.61%
MADHYA PRADESH	1,87,83,104	6.02%	364	9.52%	7,89,555	10.05%	7.77%
MAHARASHTRA	4,67,83,521	14.99%	256	6.70%	6,94,830	8.84%	10.85%
NCT OF DELHI	1,14,02,709	3.65%	3	0.08%	62,210	0.79%	1.87%
ODISHA	59,69,842	1.91%	107	2.80%	4,08,170	5.19%	2.36%
PUDUCHERRY	7,48,267	0.24%	6	0.16%	18,941	0.24%	0.20%
PUNJAB	95,55,705	3.06%	143	3.74%	1,02,026	1.30%	3.40%
RAJASTHAN	1,57,17,489	5.04%	185	4.84%	4,31,290	5.49%	4.94%

7

States/UTs	POPULATION OF STATUTORY TOWNS		STATUTORY TOWNS		OPEN DEFEACATION		Fund Share* (%)
	Pop. (minus OG)	Population Share (%)	No.	ST Share %	HHs	HH Share %	
TAMIL NADU	2,98,32,766	9.56%	721	18.86%	11,28,692	14.36%	14.21%
UTTAR PRADESH	4,06,94,476	13.04%	648	16.95%	9,65,922	12.29%	15.00%
UTTARAKHAND	24,89,380	0.80%	74	1.94%	19,206	0.24%	1.37%
WEST BENGAL	2,10,94,166	6.76%	129	3.37%	2,99,574	3.81%	5.07%
<b>NE STATES</b>	<b>65,41,295</b>		<b>218</b>		<b>42,966</b>		
ARUNACHAL PRADESH	3,13,557	4.79%	26	11.93%	4,241	9.87%	8.36%
ASSAM	33,19,375	50.74%	88	40.37%	27,900	64.94%	45.56%
MANIPUR	6,36,625	9.73%	28	12.84%	3,427	7.98%	11.29%
MEGHALAYA	3,75,930	5.75%	10	4.59%	1,887	4.39%	5.17%
MIZORAM	5,71,771	8.74%	23	10.55%	1,019	2.37%	9.65%
NAGALAND	5,05,440	7.73%	19	8.72%	2,279	5.30%	8.22%
SIKKIM	1,47,695	2.26%	8	3.67%	719	1.67%	2.96%
TRIPURA	6,70,902	10.26%	16	7.34%	1,494	3.48%	8.80%



Annexure IV

Concept Note on State Urban Sanitation Strategy for the State of \_\_\_\_\_

**PART A: Parameters determining the existing urban sanitation situation**

<b>1</b>	<b>State Profile</b>	
1.1	Name of the state	
1.2	Total Urban Population as per 2011 Census	
1.3	Number of Statutory towns 1 as per Census 2011	
1.4	Number of Census towns 2 as per Census 2011	
1.5	Population of statutory towns (as per Census 2011)	
1.6	Population of census towns (as per Census 2011)	
1.7	Total number of urban households	

<b>2</b>	<b>Status of Sanitation Situation as per Census 2011 [FOR STATUTORY TOWNS ONLY]</b>	<b>Total nos. as per Annexure 1 (State)*</b>
2.1	Number of urban households resorting to open defecation (not in premises - open)	
2.2	Number of urban households having pit latrines	
2.3	Number of urban households having insanitary latrines	

<b>3</b>	<b>Solid waste management (tentative quantity based on per capita waste generation) [FOR STATUTORY TOWNS ONLY]</b>	<b>Total (State)*</b>
3.1	Total Solid waste generated (in MT)	
3.2	Total Waste collected (in MT)	
3.3	Total Waste Transported (in MT)	
3.4	No. of cities with SWM Disposal Facility	
3.5	Total Waste treated (in MT)	

\*City-wise information may also be added wherever available.

PART B: Institutional Mechanism for Swachh Bharat Mission (SBM) - Urban

	Provide Details		
Name of the Nodal Agency for SBM	<i>[Provide name of Nodal Agency; else if not designated, provide details of process by which nodal agency will be appointed]</i>		
Name and Designation of Nodal Officer with contact no.	<i>[Provide name of Nodal Officer; else if not designated, provide details of process by which nodal officer will be appointed]</i>		
<b>Institutional Mechanism</b>		<b>Start date (Month / Year)</b>	<b>End date (Month / Year)</b>
a. Constitution of the State-level High Powered Committee (S- HPC)	<i>[Provide details of S- HPC; else if not constituted, provide details of process by which S- HPC will be constituted; timeline should be max. within 1 month of submission of concept note]</i>		
b. Setting up of State Mission Directorate	<i>[Provide details of Mission Directorate; else if not constituted, provide details of process by which Mission Directorate will be constituted; timeline should be max. within 1 month of submission of concept note]</i>		
c. Setting up of PMU at the state-level under SBM	<i>[Provide details of PMU set-up; else if not set-up, provide details of process by which PMU will be put in place; timeline should be max. within 3 months of submission of concept note]</i>		
<b>Submission of State Sanitation Strategy as per the National Urban Sanitation Policy, 2008 (please refer Ministry's website <a href="http://www.moud.gov.in">www.moud.gov.in</a>)</b>		<b>Start date (Month / Year)</b>	<b>Date of submission (Month / Year)</b>

**PART C: Component-wise action plan for Swachh Bharat Mission (SBM) – Urban**

**Physical Targets**

1	Targets	Baseline 2014	Cumulative Estimated Projection upto 2019	Reasons/Justification based on 2001-2011 data and other factors	Target 2014-15	Target 2015-16	Target 2016-17	Target 2017-18	Target 2018-19 (up to Oct, 2019)	Cumulative Target (2014-19)
A*	a	Construction of new individual household latrines (IHL)	[80% of Part A, 2.4]							[100% of 2014 baseline]
	b	Conversion of pit latrines into sanitary latrines	[Part A, 2.2.4]							[60% of 2014 baseline]
	c	Conversion of insanitary latrines into sanitary latrines	[Part A, 2.2.5]							[100% of 2014 baseline]
B*		Construction of Community toilets [NORM: 1 seat / 25 women and 1 seat / 35 men]	[20% of Part A, 2.4]							[100% of 2014 baseline]
C*		Construction of Public Toilets [NORM: 1 seat / 50 women and 1 seat / 100 men up to specified numbers**]	[Part A, 1.2]							[5% of 2014 baseline]
D		Solid waste Management	[No. of cities proposed to be covered]							[100% excluding the on-going project]
E		Capacity Building	[Part A, 1.3]							[100% of cities]
F		Public Awareness & IEC	[Part A, 1.3]							[100% of cities]

\*Efforts shall be made to construct the toilets within two years i.e. upto 2016-17.

\*\*Please also refer Manual on Sewerage & Sewerage Systems, Part A for more details (page No. 8-16)

**Financial Targets**

(Rs in Crores)

2	Funding [As per the funding pattern in the SBM Urban Guidelines]	2014-2019 (TOTAL)		2014-15		2015-16		2016-17		2017-18		2018-19 (upto Oct, 2019)		Remarks
		Tentative / estimated	Central Share	Tentative / estimated	Central Share	Tentative / estimated	Central Share	Tentative / estimated	Central Share	Tentative / estimated	Central Share	Tentative / estimated	Central Share	
A	a. Construction of new individual household latrines (IHL)(Based on the cost													





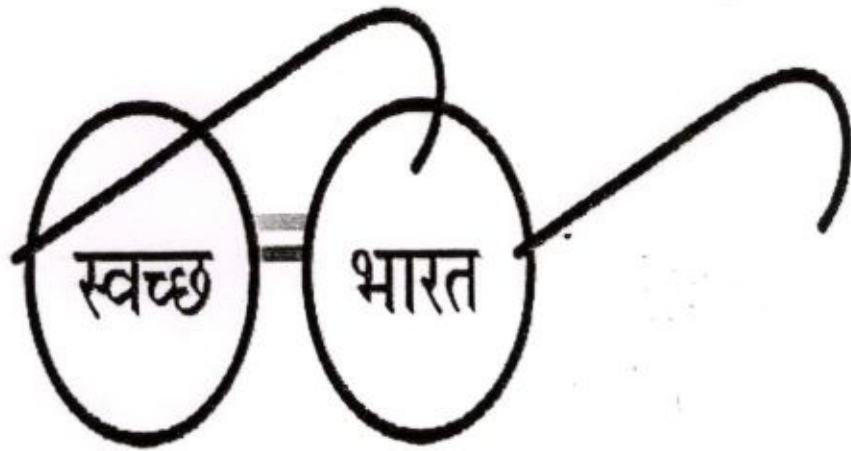

एक कदम स्वच्छता की ओर