

CHAKDAHA MUNICIPALITY
WARD NO. 19, SLUM - 71
BARUA PARA

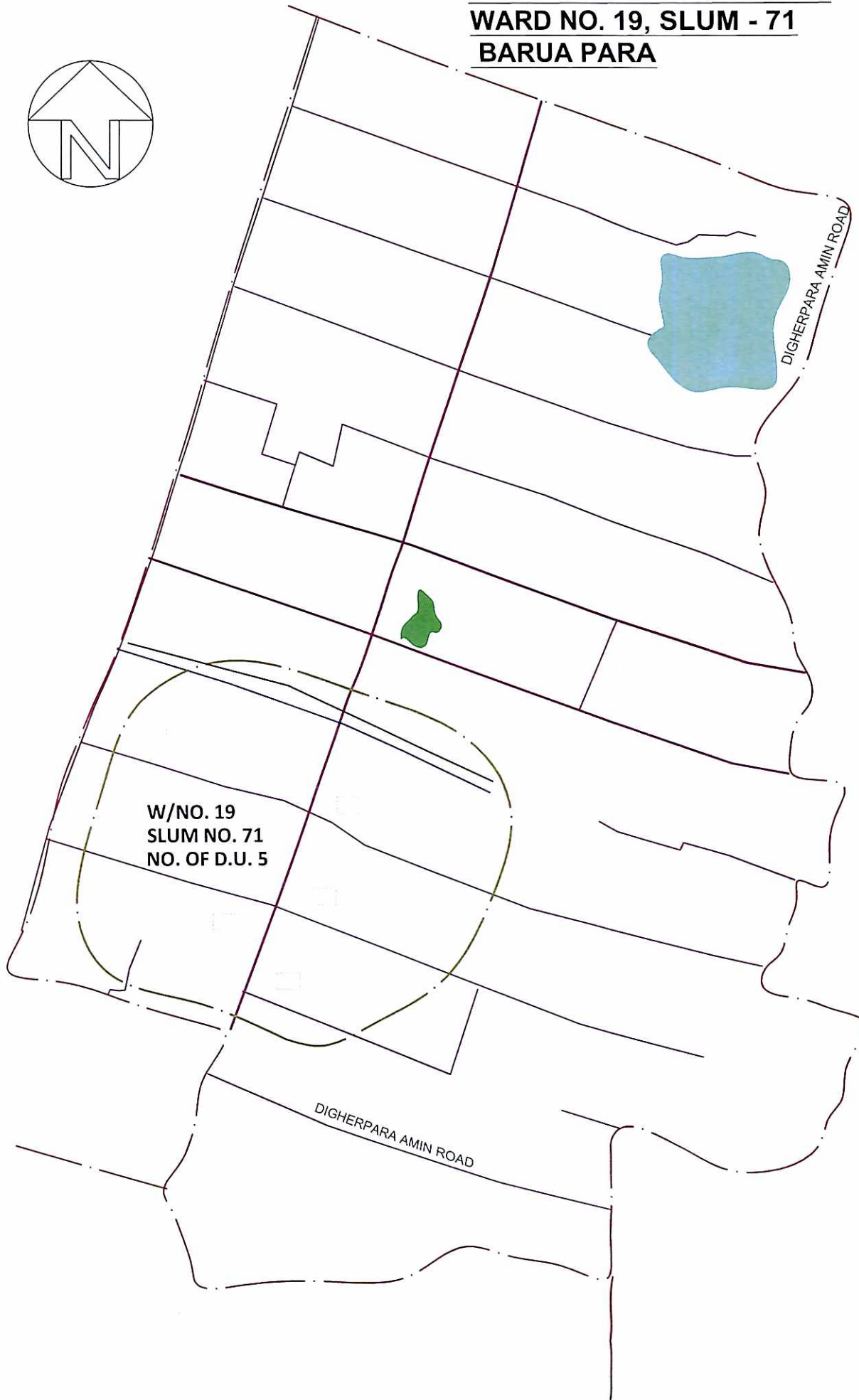

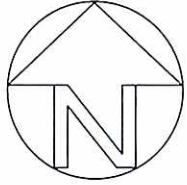





CHAKDAHA MUNICIPALITY

CONSULTANT:
 IISED, KOLKATA-700110

ASIGNMENT MANE:
 MAP SHOWING D.U. & INFRASTRUCTURE
 UNDER PMAY

21.11.15
 Chairman
 Chakdaha Municipality
 Chakdaha, Nadia

LEGEND

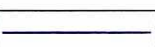
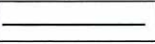
- WARD BOUNDARY 
- SLUM BOUNDARY 
- EXISTING ROAD 
- WATER BODY 
- GREEN FIELD 
- PROPOSED DWELLING UNIT 
- PROPOSED CONCRETE ROAD 
- PROPOSED DRAIN 

SIGNATURE OF APPROVING AUTHORITY :

DATE:

DWG NO.
 CHAKDAH/HFA/044

Shardha
 Sub-Assistant Engineer
 Chakdaha Municipality
 Chakdaha, Nadia

CHAKDAHA MUNICIPALITY
WARD NO. 19, SLUM - 62
JAYKRISHNAPUR

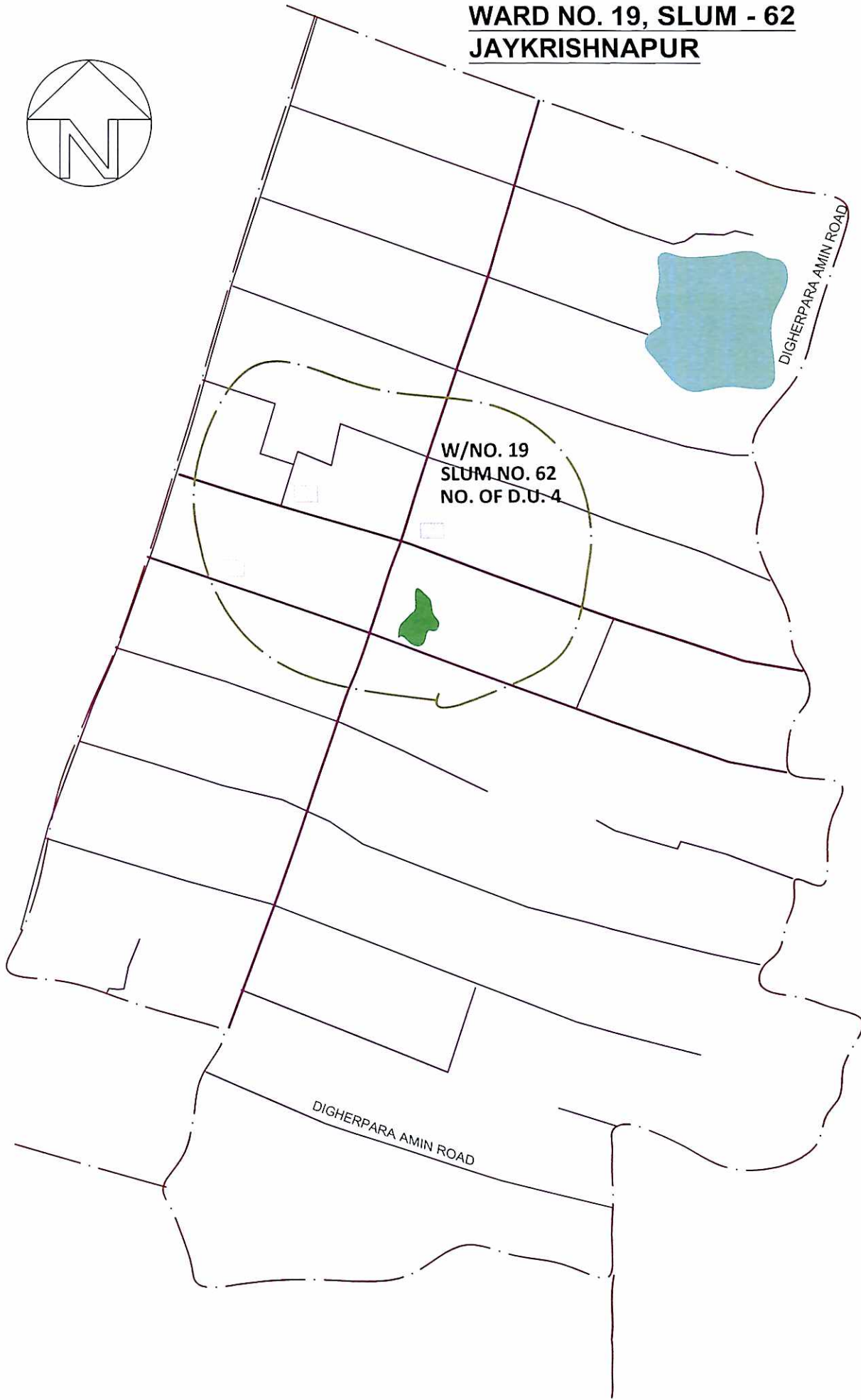
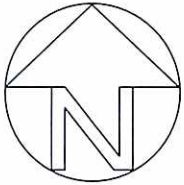

CHAKDAHA MUNICIPALITY







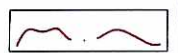

CONSULTANT:
 IISED, KOLKATA-700110

ASIGNMENT MANE:
 MAP SHOWING D.U. & INFRASTRUCTURE
 UNDER PMAY

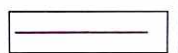
Handwritten signature and date: 19.12.15

Chakradan Chakdah Municipality Chakdah, Nadia

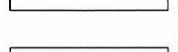
LEGEND

- WARD BOUNDARY 
- SLUM BOUNDARY 
- EXISTING ROAD 
- WATER BODY 
- GREEN FIELD 
- PROPOSED DWELLING UNIT 
- PROPOSED CONCRETE ROAD 
- PROPOSED DRAIN 

SIGNATURE OF APPROVING AUTHORITY :

DATE:

DWG NO.
 CHAKDAH/HFA/045

Chakradan
 Sub-Assistant Engineer
 Chakdah Municipality
 Chakdah, Nadia

CHAKDAHA MUNICIPALITY
WARD NO. 19, SLUM - 38
DUDHKANTI

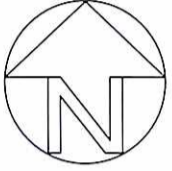

CHAKDAHA MUNICIPALITY

CONSULTANT:
 IISED, KOLKATA-700110

ASIGNMENT MANE:
 MAP SHOWING D.U. & INFRASTRUCTURE
 UNDER PMAY

LEGEND

WARD BOUNDARY	
SLUM BOUNDARY	
EXISTING ROAD	
WATER BODY	
GREEN FIELD	
PROPOSED DWELLING UNIT	
PROPOSED CONCRETE ROAD	
PROPOSED DRAIN	

SIGNATURE OF APPROVING AUTHORITY :

DATE:

DWG NO.
 CHAKDAH/HFA/046

21.12.15
Chakman
 Chakdah Municipality
 Chakdah, Nadia

Sub-Asst. Engineer
 Chakdah Municipality
 Chakdah, Nadia

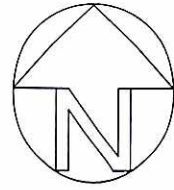

CHAKDAHA MUNICIPALITY
WARD NO. 18, SLUM - 60
VIVEKANANDAPALLY

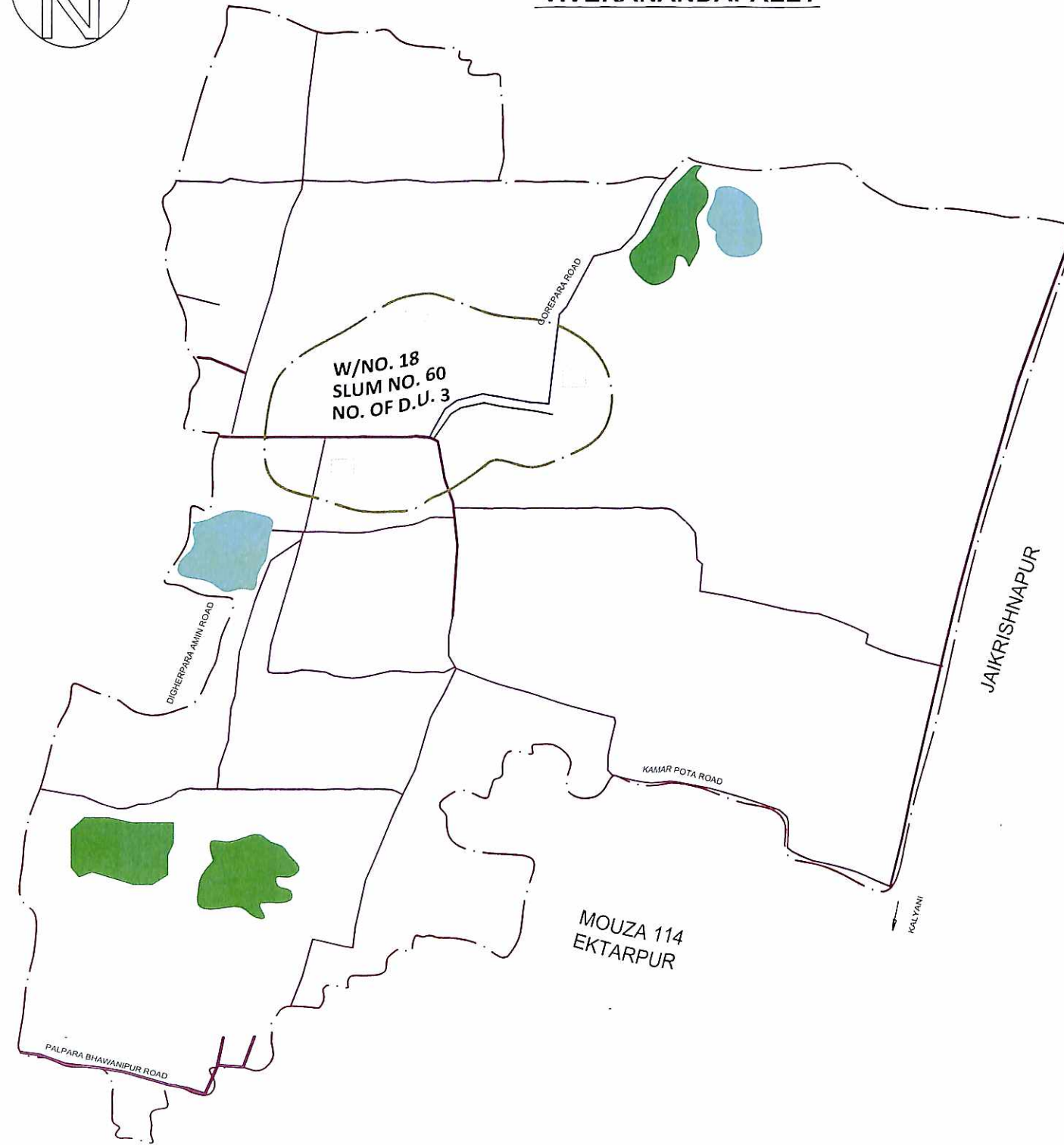

CHAKDAHA MUNICIPALITY

CONSULTANT:
IISED, KOLKATA-700110

ASIGNMENT MANE:
MAP SHOWING D.U. & INFRASTRUCTURE
UNDER PMAY

LEGEND

WARD BOUNDARY	
SLUM BOUNDARY	
EXISTING ROAD	
WATER BODY	
GREEN FIELD	
PROPOSED DWELLING UNIT	
PROPOSED CONCRETE ROAD	
PROPOSED DRAIN	

SIGNATURE OF APPROVING AUTHORITY :

DATE:

DWG NO.
CHAKDAH/HFA/047

Asankha
Sub-Assistant Engineer
Chakdaha Municipality
Chakdaha, Nadia

21.12.15
Chairman
Chakdaha Municipality
Chakdaha, Nadia

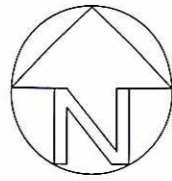

CHAKDAHA MUNICIPALITY
WARD NO. 18, SLUM - 70
UDAY NAGAR

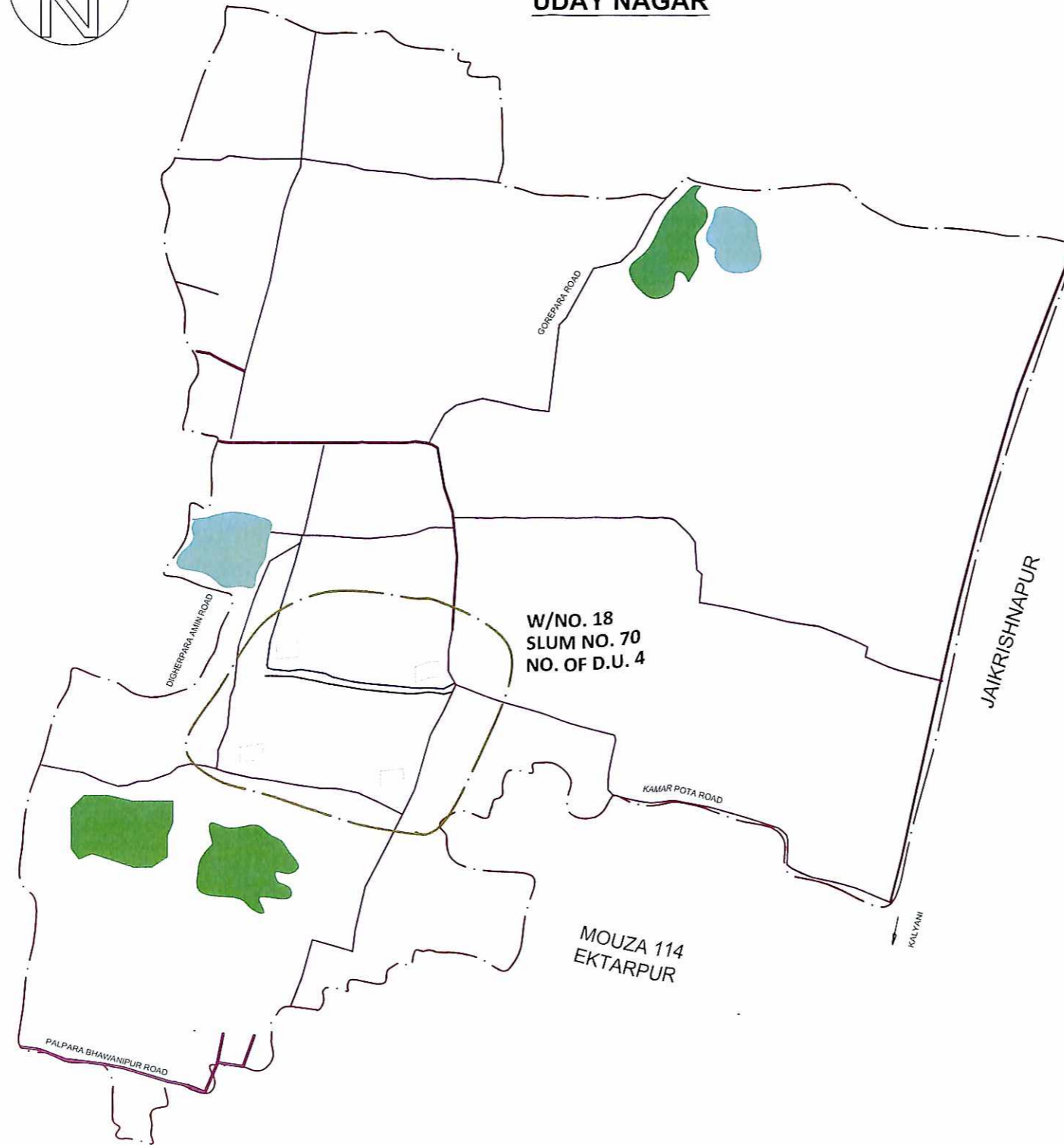

CHAKDAHA MUNICIPALITY

CONSULTANT:
IISED, KOLKATA-700110

ASSIGNMENT NAME:
MAP SHOWING D.U. & INFRASTRUCTURE
UNDER PMAY

LEGEND

WARD BOUNDARY	
SLUM BOUNDARY	
EXISTING ROAD	
WATER BODY	
GREEN FIELD	
PROPOSED DWELLING UNIT	
PROPOSED CONCRETE ROAD	
PROPOSED DRAIN	

SIGNATURE OF APPROVING AUTHORITY :

DATE:

DWG NO.
CHAKDAH/HFA/048

Abanindran
Sub-Assistant Engineer
Chakdah Municipality
Chakdah, Nadia

21.12.15
Chairman
Chakdah Municipality
Chakdah, Nadia

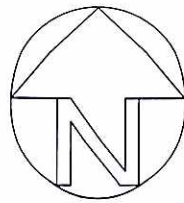

CHAKDAHA MUNICIPALITY
WARD NO. 18, SLUM - 41
UDAYNAGAR TANTI PARA

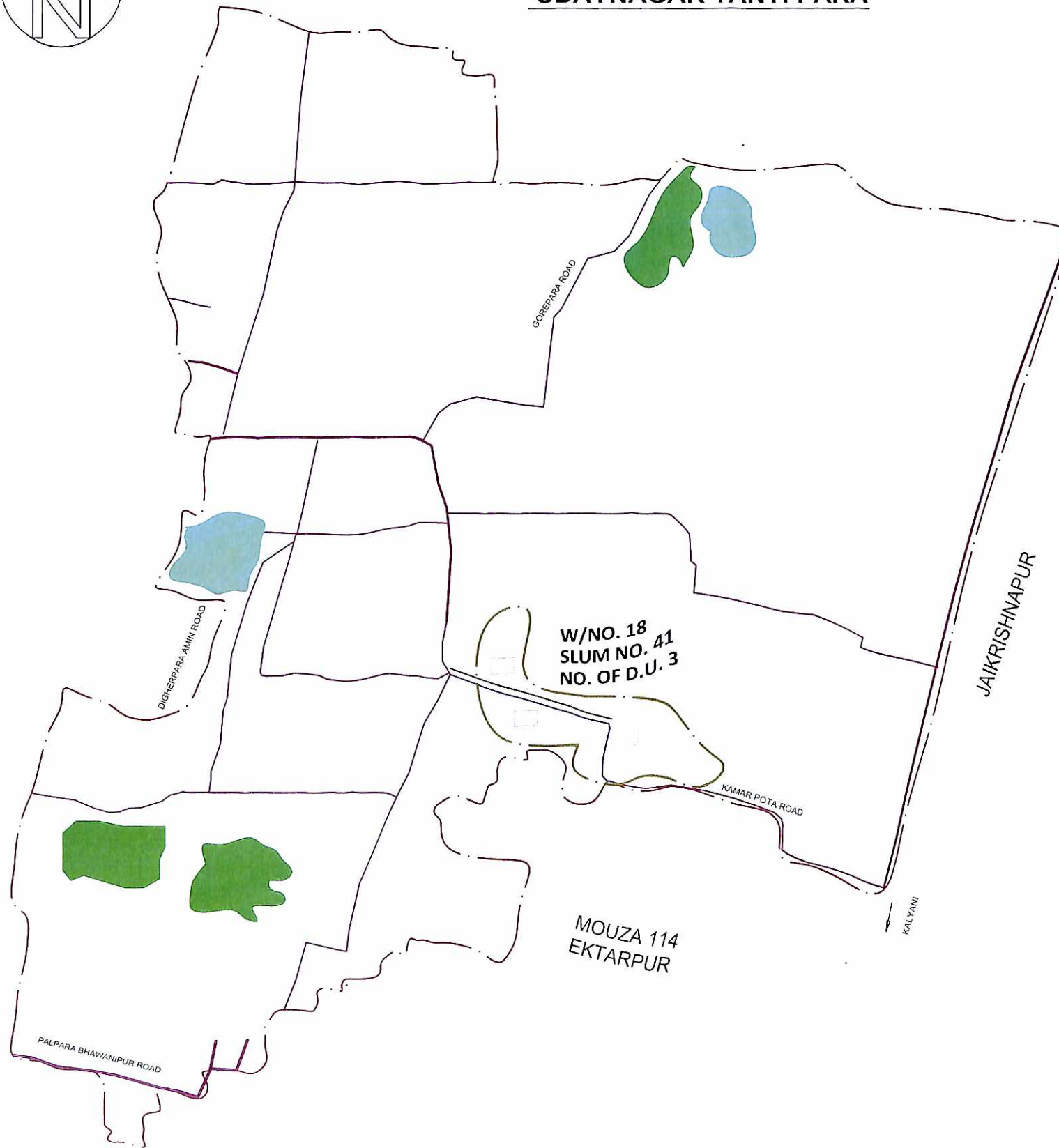

CHAKDAHA MUNICIPALITY

CONSULTANT:
IISED, KOLKATA-700110

ASIGNMENT MANE:
MAP SHOWING D.U. & INFRASTRUCTURE
UNDER PMAY

LEGEND

- WARD BOUNDARY
- SLUM BOUNDARY
- EXISTING ROAD
- WATER BODY
- GREEN FIELD
- PROPOSED DWELLING UNIT
- PROPOSED CONCRETE ROAD
- PROPOSED DRAIN

SIGNATURE OF APPROVING AUTHORITY :

DATE:

DWG NO.
CHAKDAH/HFA/049

Sankar
Sub-Assistant Engineer
Chakdaha Municipality
Chakdaha, Nadia

[Signature]
21.12.15
Chairman
Chakdaha Municipality
Chakdaha, Nadia

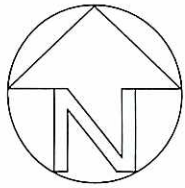

CHAKDAHA MUNICIPALITY
WARD NO. 20, SLUM 51
K.B.M. NATH PUKURPAR

WARD NO. 16

WARD NO. 2

W/NO. 20
SLUM NO. 51
NO. OF D.U. 3

WARD NO. 1

CHAKDAHA MUNICIPALITY









CONSULTANT:
IISED, KOLKATA-700110

ASIGNMENT MANE:
MAP SHOWING D.U. & INFRASTRUCTURE
UNDER PMAY

[Handwritten Signature]
21.12.15

Chairman
Chakdaha Municipality
Chakdaha, Nadia

LEGEND

- WARD BOUNDARY 
- SLUM BOUNDARY 
- EXISTING ROAD 
- WATER BODY 
- GREEN FIELD 
- PROPOSED DWELLING UNIT 
- PROPOSED CONCRETE ROAD 
- PROPOSED DRAIN 

SIGNATURE OF APPROVING AUTHORITY :

[Handwritten Signature]
Sub-Assistant Engineer
Chakdaha Municipality
Chakdaha, Nadia

DATE:

DWG NO.
CHAKDAH/HFA/050

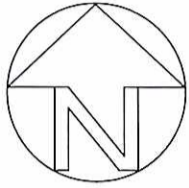

CHAKDAHA MUNICIPALITY
WARD NO. 20, SLUM - 34
K.B.M. PRADIP COLONY

WARD NO. 16

W/NO. 20
SLUM NO. 34
NO. OF D.U. 2

WARD NO. 2

WARD NO. 1









CHAKDAHA MUNICIPALITY

CONSULTANT:
IISED, KOLKATA-700110

ASIGNMENT MANE:
MAP SHOWING D.U. & INFRASTRUCTURE
UNDER PMAY

21.10.15
Chairman
Chakdaha Municipality
Chakdaha, Nadia

LEGEND

- WARD BOUNDARY 
- SLUM BOUNDARY 
- EXISTING ROAD 
- WATER BODY 
- GREEN FIELD 
- PROPOSED DWELLING UNIT 
- PROPOSED CONCRETE ROAD 
- PROPOSED DRAIN 

SIGNATURE OF APPROVING AUTHORITY :

DATE:

DWG NO.
CHAKDAH/HFA/051

Sub-Assistant Engineer
Chakdaha Municipality
Chakdaha, Nadia

CHAKDAHA MUNICIPALITY
WARD NO. 21, SLUM - 59
KBM RIC

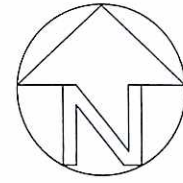







CHAKDAHA MUNICIPALITY

CONSULTANT:
 IISED, KOLKATA-700110

ASIGNMENT MANE:
 MAP SHOWING D.U. & INFRASTRUCTURE
 UNDER PMAY

21.12.15
 Chairman
 Chakdaha Municipality
 Chakdaha, Nadia

LEGEND

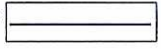
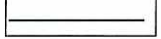
- WARD BOUNDARY 
- SLUM BOUNDARY 
- EXISTING ROAD 
- WATER BODY 
- GREEN FIELD 
- PROPOSED DWELLING UNIT 
- PROPOSED CONCRETE ROAD 
- PROPOSED DRAIN 

SIGNATURE OF APPROVING AUTHORITY :

Sub-Asst
 Sub-Assistant Engineer
 Chakdaha Municipality
 Chakdaha, Nadia

DATE:

DWG NO.
 CHAKDAH/HFA/052

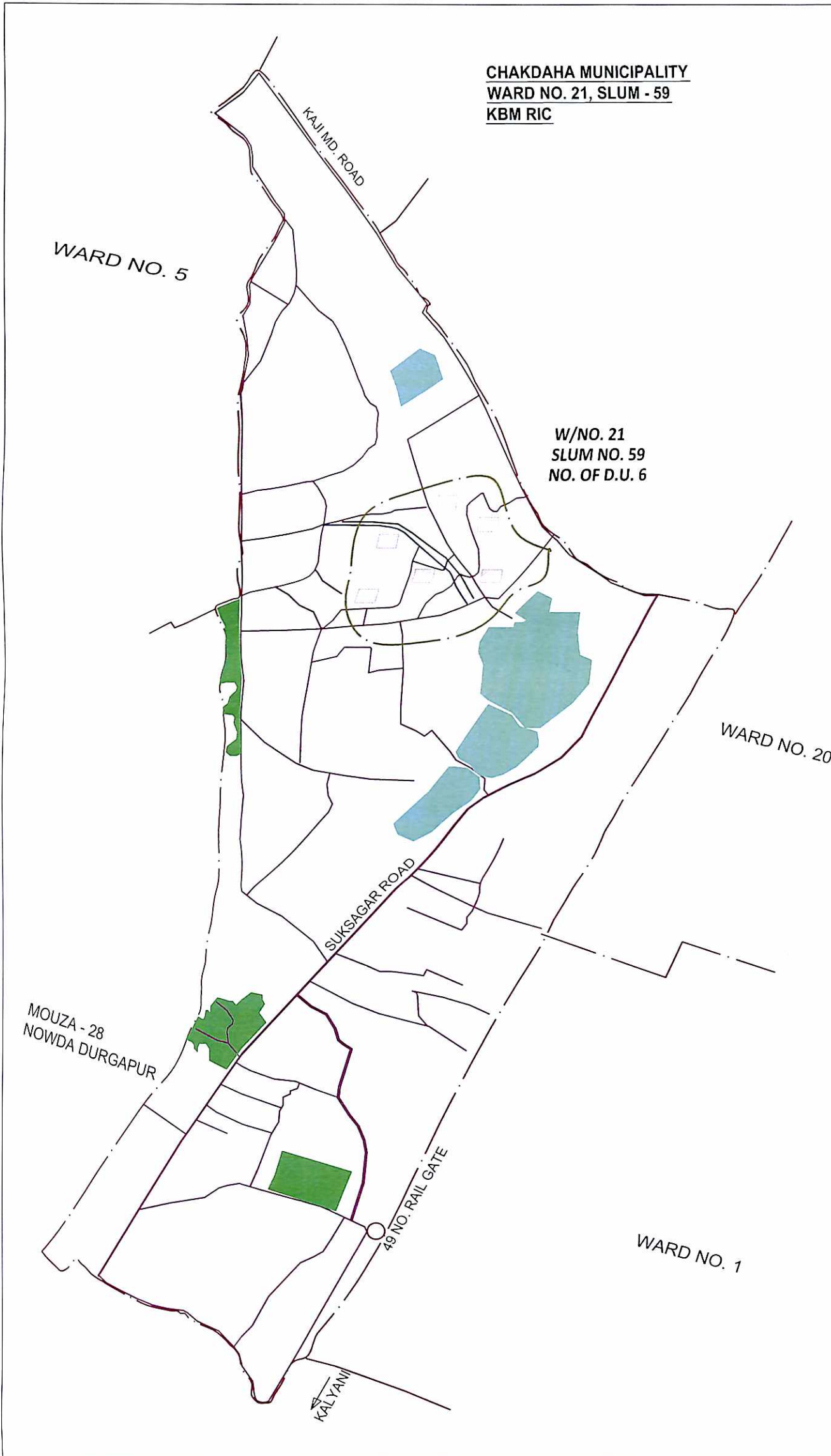

Drawing & Estimate of Dwelling Unit

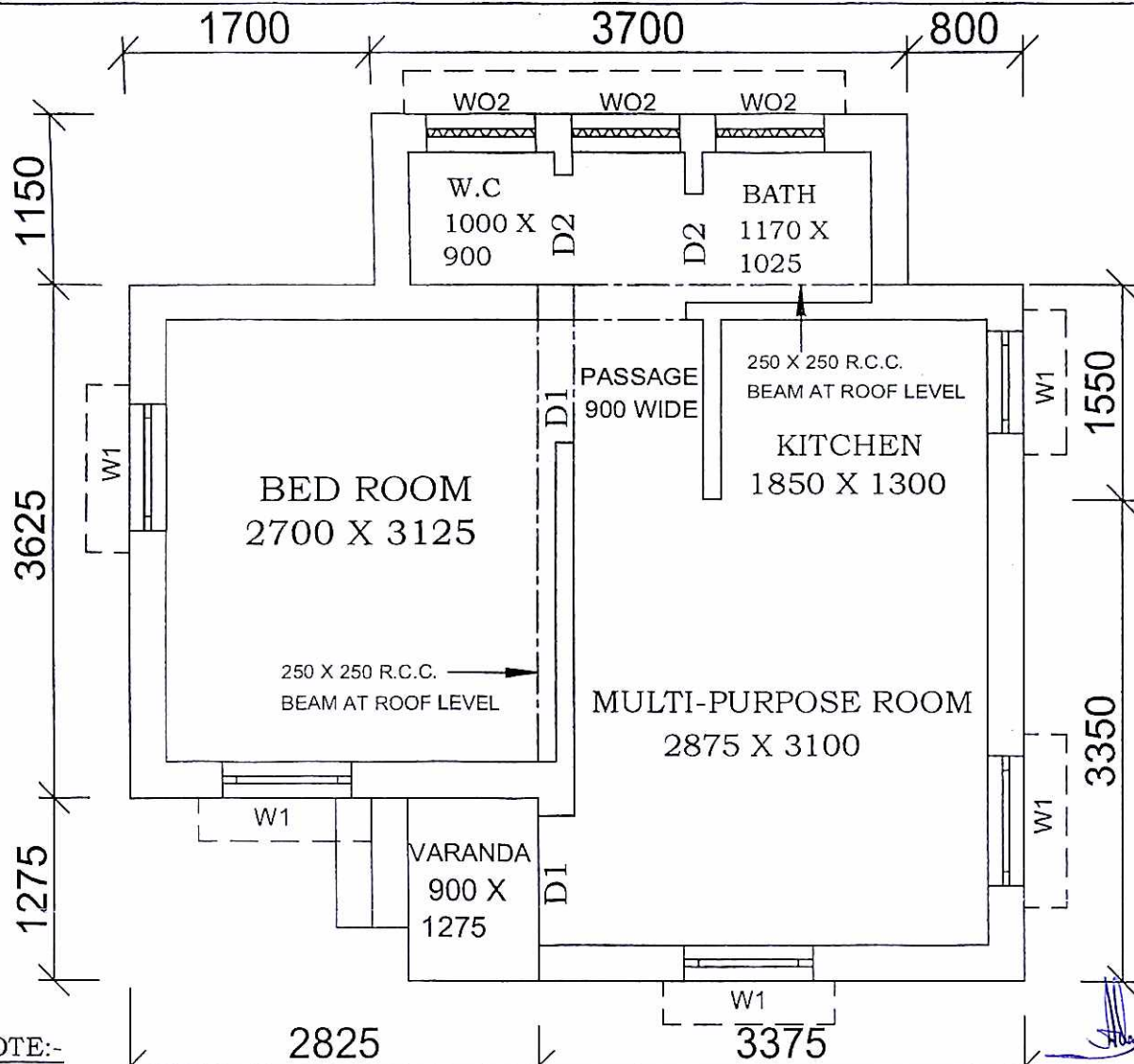

NOTE:-

1. ALL WINDOW OPENINGS (W1&W2) WILL BE PROVIDED WITH Z-BATTEN SHUTTERS.
2. ALL DOORS (D1&D2) -25TH Z-BATTEN SHUTTERS, SINGLE LEAF.
3. WO2 - OPENING PROVIDED WITH R.C.C. JALLI.
4. PLINTH HEIGHT - 450 TH.
5. CEILING HEIGHT - 2750 TH.
6. MAIN WALL - 250 TH.
7. PARTITION WALL - 125 TH.
8. ROOF SLAB, BEAM, LINTEL, ETC. WITH REINFORCED CEMENT CONCRETE M20 GRADE.
9. FLOOR OF VERANDAH, WC, BATH, & KITCHEN ROOM TO BE KEPT 15 MM BELOW THE FLOOR LEVEL OF ROOM & PASSAGE.
10. 100 MM TH. PIECE LINTEL OVER OPENING HAVE BEEN PROVIDED.
11. ALL DIMENSION ARE IN MM.

DOORS & WINDOWS SCHEDULE	
MARKING	DIMENSION
W1	900 X 900
W2	750 X 900
WO2	750 X 750
D1	900 X 2100
D2	750 X 2100

Chief Engineer
M.E. Directorate
Deptt. of Municipal Affairs
Govt. of West Bengal
FLOOR AREA - 25.37 SQM.
BUILT UP AREA - 32.18 SQM.

FOUNDATION DETAILS

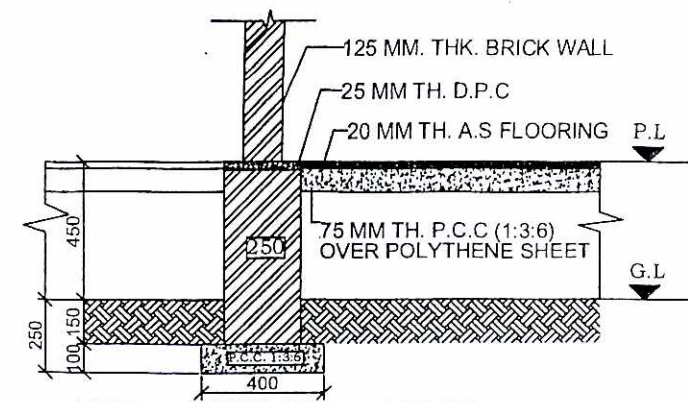

125 MM THK. BRICK WALL

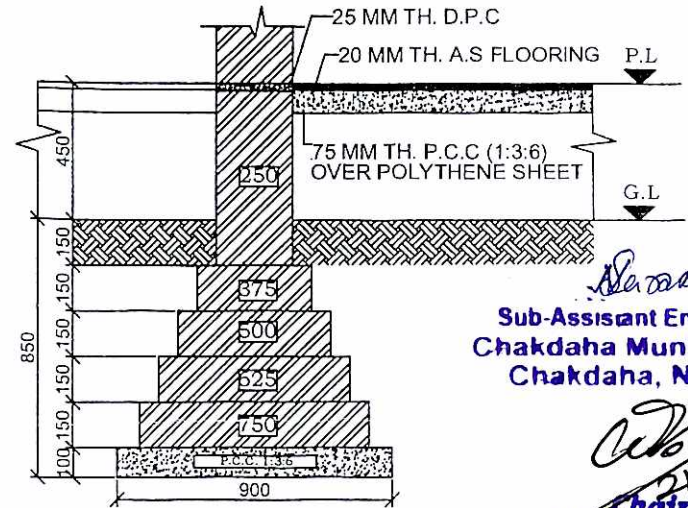

250 MM THK. BRICK WALL

Sankar
Sub-Assistant Engineer
Chakdaha Municipality
Chakdaha, Nadia

22.12.15
Chairman
Chakdaha Municipality
Chakdaha, Nadia

PRADHAN MANTRI AWAS YOJANA
HOUSING FOR ALL (URBAN)

OFFICE OF THE CHIEF ENGINEER
MUNICIPAL ENGINEERING DIRECTORATE
GOVT. OF WEST BENGAL

DWG. NO. _____ SCALE :- 1:50 & 1:25

DETAILED ESTIMATE FOR THE CONSTRUCTION OF SINGLE UNIT DWELLING HOUSE

Pradhan Mantri Awas Yojana Housing For All (Urban)

Total Covered Area- 32.18 sq.m (With Electrical Works)

Reference of Schedule of Rates : PWD (W.B.), Schedule of Rates Building & Sanitary w.e.f-01.07.2014 & Corrigenda
Kolkata /24 Pgs (N & S)/ Kalyani Sub Div.)

Floor Area 25.37 sqm

SL No.	Description of Works	Quantity	Unit	Rate (Rs.)	Amount (Rs.)
1	Earthwork in excavation in foundation trenches or drains, in all sorts of soil (including mixed soil but excluding laterite or sandstone) including removing spreading or stacking the spoils within a lead of 75 m as directed including trimming the sides of trenches, levelling, dressing and ramming the bottom, bailing out water etc. as required complete. a) Depth of excavation not exceeding 1500mm . SOR, PWD, P-1, I -2 a	13.000	%cu.m	12047.00	1566.11
2	Earth work in filling in foundation trenches or plinth with good earth in layers not exceeding 150 mm. including watering and ramming etc. layer by layer complete.(Payment to be made on the basis of measurement of finished quantity of work) a) With earth obtained from excavation of foundation. SOR, PWD, P-1, T/3 a	11.120	%cu.m	7831.00	870.81
3	Supplying Laying Polithin Sheets etc. SOR, PWD, P-45, T - 13	22.000	sqm	25.00	550.00
4	Cement concrete with graded Stone ballast (40 mm.) excluding shuttering.a) In ground floor and foundation.6 : 3 : 1 proportion Pakur variety SOR, PWD, Page 24 ; Item -10 a	3.500	cu.m.	5823.00	20380.50
5	25 mm. thick damp proof with cement concrete (4:2:1) (with graded stone aggregate 10 mm. Normal size) and painting the top surface with a coat of bitumen using 1.7 kg. per sq.m. including heating the bitumen and cost and carriage of all materials complete. SOR, PWD, P-45, T-12	6.810	sqm,	297.00	2022.57
6	Brick work with 1st class bricks in cement mortar (6:1) a) In foundation and plinth. b) In super structure SOR, PWD, P-29, T -22(a), (b)	10.430 15.240	cum cum	5719.00 5943.00	59649.17 90571.32
7	125mm thick brick work with 1st. class bricks in cement mortar (4:1). a) In ground floor SOR, PWD, P-73, I -29	23.220	sq.m.	783.00	18181.26
8	Ordinary Cement concrete (mix 1:1.5:3) with graded stone chips (20 mm nominal size) excluding shuttering and reinforcement if any, in ground floor as per relevant IS codes. (i) Pakur Variety SOR, PWD, P-14, T -7(i)	3.940	cu.m.	6851.66	26995.54
9	Reinforcements for reinforced concrete work in all sorts of structures including distribution bars, stirrups, binders etc. including supply of rods, initial straightening and removal of loose rust (if necessary), cutting to requisite length, hooking and bending to correct shape, placing in proper position and binding with 16G black annealed wire at every intersection, complete as per drawing and direction. (a) For works in foundation, basement and upto roof of ground floor / upto 4m. (i) Tor steel/Mild steel. SOR, PWD, P-27, T -15(i)	0.309	MT	60705.93	18775.74

Sl No.	Description of Works	Quantity	Unit	Rate (Rs.)	Amount (Rs.)
10	Hire and labour charges for shuttering with centreing and necessary staging upto 4 m. using approved stout props and thick hard wood planks of approved thickness with required bracing for concrete slabs, beams, columns, lintels curved or straight including fitting, fixing and striking out after completion of works. (upto roof of ground floor). (When the height of a particular floor is more than 4 m. the equivalent floor ht. shall be taken as 4 m. and extra for works beyond the initial 4 m. ht. shall be allowed under 12(e) for every 4 m. or part thereof.) SOR, PWD, P-66, T -12(a) 25 mm. to 30 mm. thick wooden shuttering as per decision & direction of Engineer-in-charge. Ground Floor	37.063	M ²	360.00	13342.68
11	Plaster (to wall, floor, ceiling etc.) with sand and cement mortar including rounding off or chamfering corners as directed and raking out joints or roughening of concrete surface, including throating, nosing and drip course where necessary . In ground floor. A) With 6:1 cement mortar. a) Inside wall 20 mm thick plaster SOR, PWD, P-151, T -2 (i)(b) b) Out side Wall, 15mm th. SOR, PWD, P-151, I -2 (i)(c) B)10mm th ceiling plaster (4:1) SOR, PWD, P-151, I -2 (i)(c)	116.940	sq.m.	181.00	21166.14
		111.950	sq.m.	156.00	17464.20
		23.330	sq.m.	140.00	3266.20
12	Neat cement punning about 1.5mm thick in wall, dado, window, sills, floor, drain etc. SOR, PWD, P-152, I -8	26.700	sq.m.	38.00	1014.60
13	Artificial stone in floor,dado, staircase etc. with cement concrete (4:2:1) with stone chips laid in panels as directed with topping made with ordinary or white cement (as necessary) and marble dust in proportion (2:1) including smooth finishing and rounding off corners and including application of cement slurry before flooring works, using cement @ 1.75 kg./sq.m. all complete including all materials and labour. In ground floor. 3 mm. thick topping (High polishing grinding on this item is not permitted) with ordinary cement. 20mm thick SOR, PWD, P-40, I -3 (i)	26.490	sq.m.	265.00	7019.85
14	Supplying, fitting & fixing MS clamp for fixing door and window frame made of flat bent bar, end bifurcated, fixed in cement concrete with stone chips (4:2:1)a fitted and fixed omplete as per direction. 40mm x 6mm x 125 mm length. (Cost of cement concrete will be paid separately) SOR, PWD, P-90, I -18 (c)	34	each	22.00	748.00
15	Wood work in door and window frame fitted and fixed complete including a protective coat of painting at the contact surface of the frame other Local wood SOR, PWD, P-85, T -1(i)	0.213	cu.m.	46171.00	9834.42
16	Panel Shutter of door & Window (each Panal Consisting Of single Plan without Join) 25 mm thick shutter with 12 mm thick Panal of size 30 to 45 cm. Other Local wood SOR, PWD, P-105, I -84 (iv)c	8.520	sq.m.	1567.00	13350.84
17	Iron butt hinges of approved quality fitted and fixed with steel screws, with ISI mark. a)75mm x 47mm x 1.70mm SOR, PWD, P-91, T -20(iv)	32.000	each	34.00	1088.00
18	Iron Socket Bolt of approved quality fitted and fixed complete. i) 150 mm long x 10 mm dia SOR, PWD P-93, I-25,c	11.000	each	71.00	781.00
19	White washing including cleaning and smoothening surface thoroughly (5 parts of stone lime and 1 part of shell lime should be used in the finishing coat). Two Coats SOR, PWD, P-155, I -3 (b)	124.960	%sq.m	1887.00	2358.00
0	Colour washing with ella with a coat of white wash priming including cleaning and smoothening surface thoroughly external surface One Coat SOR, PWD, P-155, I - 4(ii)(a)	100.560	%sq.m	1514.00	1522.48

SL No.	Description of Works	Quantity	Unit	Rate (Rs.)	Amount (Rs.)
21	Priming one coat on timber, plastered or on steel or other metal surface with synthetic enamel/oil bound primer of approved quality including smoothening surfaces by sand papering etc. 1) On timber surface SOR, PWD, P - 162, I - 7(a) 2) On Steel Surface SOR, PWD, P - 162, I - 7(b)	21.690 2.700	sq.m. sq.m.	41.00 31.00	889.29 83.70
22	Painting with best quality synthetic enamel paint of approved make and brand including smoothening surface by sand papering etc. including using of approved putty etc. on the surface, if necessary : With super gloss (hi-gloss)-With any shade except white. a) On timber or plastered surface Two Coats b) On Steel surface Two Coats SOR, PWD, P - 162, - 8A(aii),(bii)	21.690 2.700	sq.m. sq.m.	89.00 86.00	1930.41 232.20
23	Iron hasp bolt of approved quality fitted and fixed complete (oxidised) with 16 mm dia with center bolt and round fitting. 300 mm long SOR, PWD, P-93, I - 27c	2.000	each	193.00	386.00
24	Precast pried concrete jally work as per design and manufacture's specification including moulding etc. with stone chips and necessary reinforcement shuttering complete including fitting, fixing in position in all floors. (a) 37.5 mm th. panels Cement & steel required for this item will not be issued by deptt. SOR, PWD, P-32, I - 38 (b)	1.690	sq.m.	351.00	593.19
25	Supplying, fitting and fixing UPVC down pipes A type and fittings conforming to IS 13592-1992 with necessary clamps nails including making holes in walls, etc. and cutting trenches in any soil, through masonry concrete structure etc. if necessary and mending good damages including jointing with jointing materials (Spun yarn, valamoid / bitumen / M. seal etc.) complete. P-173, I-21 A (ii), C(ii), D(ii) SOR, PWD, P173, I - 21 A (ii), C(ii), D(ii) i) UPVC Pipe 110 mm dia ii) UPVC Bend 87.5 degree 110 mm dia iii) UPVC Shoe 110 mm	3.000 2.000 1.000	Mtr. each each	291.00 162.00 128.00	873.00 324.00 128.00
26	M.S.or W.I. Ornamental grill of approved design joints continuously welded with M.S, W.I. Flats and bars of windows, railing etc. fitted and fixed with necessary screws and lugs in ground floor. Grill weighing 10 kg/sq m to16 kg/m2 SOR, PWD, P - 76, I - 10 (i) (2.70sqm @ 10.5kg per sqm = 28.35 kg)	0.284	Qntl	8247.00	2342.15
27	Shallow water closet Indian pattern(I.P.W.C.) of approved make in white vitreous chinaware supplied ,fitted and fixed in position (excluding cost of concrete for fixing). 450 mm long SOR, PWD, (Sanitary) P - 65, I - 1 (iii)	1.000	each	1062.00	1062.00
28	Foot rest for water closet of size 275 mm X 125 mm with Artificial stone(4:2:1) with 6 mm stone chips and chequered including adding colour as necessary. SOR, PWD, (Sanitary) P - 66, I - 9	1.000	Pair	70.00	70.00
29	Supplying,fitting and fixing cast iron 'P' or 'S' trap conforming to I.S. 3989 / 1970 and 1729 / 1964 including lead caulked joints and painting two coats to the exposed surface. S Trap 100 mm SOR, PWD, (Sanitary) P - 54, I - 14(B-iii)	1.000	each	923.00	923.00
30	Supplying, fitting fixing CI Round Gratings 150mm dia SOR, PWD, (Sanitary) P - 55, I - 18(ii)	1.000	Each	100.00	100.00

Sl No.	Description of Works	Quantity	Unit	Rate (Rs.)	Amount (Rs.)
	Construction of 2 circular leach pit of inside diameter 1000 mm. & a depth of 1000 mm. With a layer of 250 mm. Thick brick work with cement mortar (6:1) & honeycombed brick wall (4:1) at every alternate layer upto a height of 925 mm. From bottom and then 125 mm. thick brick wall (4:1) for a height of 300 mm. and covered with 75m. RCC slab (4:2:1) with 8mm tor steel @ 150 mm. centre to centre both ways including plastering and neat cement punning on top of the slab and making hooking arrangment on slab for lifting of the slab if require as well as jointing the connection with the inspection pit (450 x 450) covered with 50mm thick RCC slab (4:2:1) with stone chips and necessary reinforcement and connected with 100 mm dia PVC pipe laid over rammed earth and then covered the pipe properly with powder earth including supplying fitting fixing fibre glass pan P-tap & polythene pipe as per requirement to connect with the inspection pit complete with all respect as per direction of EIC.(ANNEXURE-II)	1	Item	7544.00	7544.00
TOTAL AMOUNT			Rs.		350000.36
Say			Rs.		350000.00
Add for Electrical Works (ANNEXURE-I)			Rs.		17858.00
TOTAL AMOUNT			Rs.		367858.00
(Rupees Three lakh Sixty seven thousand Eight hundred & Fifty eight only)					

Shankar.
Sub-Assistant Engineer
Chakdaha Municipality
Chakdaha, Nadia

Chakdaha
21.12.15
Chairman
Chakdaha Municipality
Chakdaha, Nadia

Chief Engineer
Chief Engineer
M.E. Directorate
Deptt. of Municipal Affairs
Govt. of West Bengal

(ANNEXURE-II)

Sl No	Description of Items	Quantity	Unit	Rate	Amount
1	Earth work in excavation of foundation trenches or drains in all sorts of soil (including mixed soil but excluding or stacking the spoils within a lead of 75 m. as directed. The item includes necessary trimming the sides of trenches leveling dressing and ramming the bottom boiling out water as required complete. Depth of excavation not existing 1500mm P.No-1, I-2(a)	2.500	%Cu.M	12047.00	301.18
2	Cement concrete with graded jhama Khoa ballast (30 mm size) excluding shuttering. In ground floor and foundation (a) 6:3:1 proportion.	0.050	Cu.M	5803.06	290.15
3	Brick work with 1st class bricks in cement mortar (6 :1). a) In foundation & Plinth P.no-29, I-21(a)	0.010	Cu.M	5719.00	57.19
4	125 mm. thick brick work with 1st class bricks in cement mortar (4 : 1) G.Floor P.no-31 I-29	3.000	SqM	714.00	2,142.00
5	Controlled Cement concrete with well graded stone chips (20 - mm nominal size) excluding shuttering and reinforcement with complete design of concrete as per I : 456 and relevant special publications submission of job mix formula after preliminary mix design after testing of concrete cubes as per direction of Engineer-in charge Consumption of cement will not be less than 300 Kg of cement -with Super plasticiser per cubic meter of controlled concrete but actual consumption will be determined on- the basis of preliminary test and job mix formula. -In ground floor and foundation. [Using concrete mixture] M 20 Grade P.no-12. I-6(a)	0.145	Cu.M	6871.54	996.37
6	Reinforcement for reinforced concrete work in all sorts of structures incl. Distribution bars, stirrups, binder etc. incl. supply of rods, initial straightening & removal of loose rust (if necessary), cutting to requisite length, hooking etc P.no-27, I-15(a)(i)	0.010	M.T	68508.00	685.08
7	Supplying, fitting and fixing UPVC down pipes A type and fittings conforming to IS 13592-1992 with necessary clamps nails including making holes in walls, etc. and cutting trenches in any soil, through masonry concrete structure etc. if necessary and mending good damages including jointing with jointing materials (Spun yarn, valamoid / bitumen / M. seal etc.) complete.				
	i) UPVC Pipe 110 mm dia P.no-173, I-	4.000	Mtr	291.00	1,164.00
	ii) UPVC Bend 87.5 degree 110 mm dia P.no-174, I-21(B)C(ii)	2.000	Each	162.00	324.00
8	Jaffri brick work 125 mm. thick with 1st class bricks in cement mortar (4:1) including 12 mm. thick cement plaster (4:1) in all faces in ground floor P.no-32, I-35	2.000	SqM	792.00	1,584.00
Cost of 2 no leach pit					7,543.97
Total					7,544.00

Sankar
Sub-Assistant Engineer
Chakdaha Municipality
Chakdaha, Nadia

21/12/15
Chairman
Chakdaha Municipality
Chakdaha, Nadia

Drawing & Estimate of Concrete Road

Sub-Assistant Engineer
Chakdaha Municipality
Chakdaha, Nadia

Pradha P.

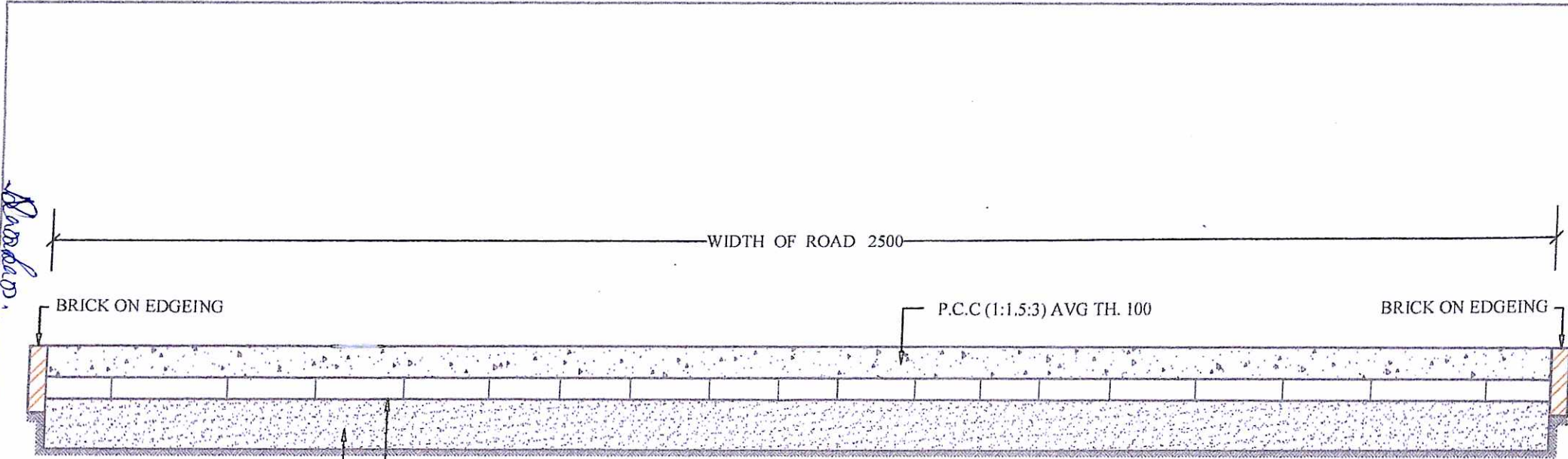

BRICK ON EDGEING

WIDTH OF ROAD 2500

P.C.C (1:1.5:3) AVG TH. 100

BRICK ON EDGEING

200 TH. SILVER SAND FILLING

SINGLE BRICK FLAT SOLING

NOTE : 1. CEMENT CONCRETE SHOULD BE LAID IN ALTERNATE PANNEL OF AN AREA NOT MORE THAN 7.50 SQM. PROVISION FOR PAPER JOINT AT THE END OF EACH PANNEL IS TO BE MADE
2. ALL DIMENSIONS ARE IN MM.

TYPICAL CROSS SECTION OF CEMENT CONCRETE ROAD

**PRADHAN MANTRI AWAS YOJANA
HOUSING FOR ALL (URBAN)**

**OFFICE OF THE CHIEF ENGINEER
MUNICIPAL ENGINEERING DIRECTORATE
GOVT. OF WEST BENGAL**

DWG. NO.

Chairman
Chakdaha Municipality
Chakdaha, Nadia

Chakdaha
21.12.15

**ESTIMATE OF CEMENT CONCRETE ROAD UNDER PMAY
(UNIT LENGTH AND WIDTH 2.5m)**

Sl.No.	Description of item	Quantity	Unit	Rate	Amount
1 Pg.-1,I-1	Surface Dressing of the ground in any kind of soil including removing vegetation inequalities not exceeding 15 cm depth and disposal of the rubbish within a lead upto 75 m as directed.	2.5	m ²	11	27.5
2 Pg.-1,I-2	Earth work in excavation of foundation trenches or drains, in all sorts of soil (including mixed soil but excluding laterite or sandstone) including removing, spreading or stacking the spoils within a lead of 75 m. as directed. The item includes necessary trimming the sides of trenches, levelling, dressing and ramming the bottom, bailing out water as required complete. (a) Depth of excavation not exceeding 1,500 mm.	0.312	%m ³	12047	37.59
3 Pg.-11,I-1	Single Brick Flat Soling of picked jhama bricks including ramming and dressing bed to proper level and filling joints with local sand.	2.5	m ²	377	942.5
4 Pg.-26,I-12 (f)	Hire and labour charges for shuttering with centering and necessary staging upto 4 m using approved stout props and thick hard wood planks of approved thickness with required bracing for concrete slabs, beams and columns, lintels curved or straight including fitting, fixing and striking out after completion of works (upto roof of ground floor) (f) 25 mm to 30 mm shuttering without staging in foundation	0.2	m ²	225	45
5 Pg.-11,I-5	Ordinary Cement concrete (mix 1:2:4) with graded stone chips (20 mm nominal size) excluding shuttering and reinforcement, if any, in ground floor as per relevant IS codes. a) Pakur Variety	0.25	m ³	6111.98	1527.99
6 Pg.-1,I-3(a)	Earth work in filling in foundation trenches or plinth with good earth, in layers not exceeding 150 mm. including watering and ramming etc. layer by layer complete. (Payment to be made on the basis of measurement of finished quantity of work) (a) With earth obtained from excavation of foundation.	0.312	%m ³	7831	24.43

TOTAL= 2605.01

Sub-Asst. Engr.
Sub-Assistant Engineer
Chakdaha Municipality
Chakdaha, Nadia

Chairman
21.12.15
Chairman
Chakdaha Municipality
Chakdaha, Nadia

Drawing & Estimate of Drain

CROSS SECTION OF DRAIN (400 x 400)

15 MM TH.
PLASTERING IN 1:4
NEAT CEMENT
FINISH

B.F.S
IN 1:4 CM

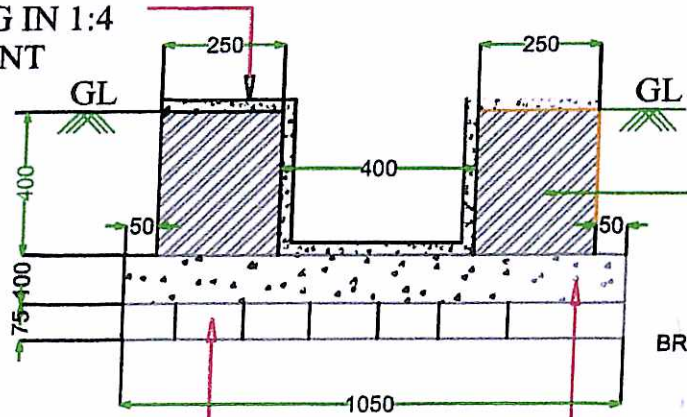

BRICKWORK IN (1:4) CEMENT
MORTAR

100 MM TH. P.C.C (1:2:4) OVER
75 TH. BRICK FLAT SOLING

Sankar

Sub -Assistant Engineer

Sub-Assistant Engineer
Chakdaha Municipality
Chakdaha, Nadia

[Signature]

21.12.15

Chairman

Chairman
Chakdaha Municipality
Chakdaha, Nadia

Abstract of Estimated Cost for Drain section of 400mm x 400mm

All rates are taken from P.W.D. Schedule 2014 ,Kolkata location followed.

Length= 1.0 Mtr.

Sl. No	Description						UNIT	QTY.	RATE (RS.)	AMOUNT (RS.)
	Details	No	L	B	H	Qty.				
1	Earth work in excavation of foundation trenches or drains. In all sorts of soil (including mixed soil but excluding laterite or sandstone) including removing. Spreading or stacking the spills within a lead of 75m. As directed. The item includes necessary trimming the sides of trances, leveling dressing and ramming the bottom complete a) Depth of excavation not exceeding 1500mm. Page-1, Item-2.						%Cum	0.60	12,047.00	72.73
	For drain	1.0	1.000	1.05	0.575	0.60				
2	Earth work in filling in foundation trenches or plinth with good earth. In layers not exceeding 150 mm. including watering and ramming etc. layer by layer complete. (Payment to be made on basis of measurement of finished quantity of work). (a) With earth obtained from excavation of foundation. Page-1, Item No.-3.a						%Cum	0.04	7,831.00	3.13
	Consider total Earth	2.0	1.000	0.050	0.400	0.04				
3	Single Brick Flat Soling of picked jhama bricks including ramming and dressing bed to proper level and filling joints with local sand. Page-11, Item-1.						Sqm	1.05	377.00	395.85
	For drain	1.0	1.000	1.050		1.05				
4	Ordinary Cement concrete (mix 1:2:4) with graded stone chips (20 mm nominal size) excluding shuttering and reinforcement, if any, as per relevant IS codes. A) Pakur Variety. Page-11, Item-5.a a)Ground floor.						Cum	0.11	4,603.00	483.32
	For drain	1.0	1.000	1.050	0.100	0.11				
5	Brick work with 1st class bricks in cement mortar (4:1) (a) In foundation and plinth Page-29, Item No.-21.a						Cum	0.2	6,068.00	1,213.60
	For drain	2.0	1.000	0.250	0.400	0.20				
6	Plaster (to wall, floor, ceiling etc.) with sand and cement mortar including rounding off or chamfering corners as directed and raking out joints including throating, nosing and drip course, scaffolding/staging where necessary (Ground floor).[Excluding cost of chipping over concrete surface] (ii) with 1:4 cement mortar Page-151, Item-2.ii.b (a) 15mm thick plaster						m ²	1.7	176.00	299.20
	For drain	1.0	1.000	1.700		1.70				
7	Neat cement punning about 1.5mm thick in wall,dado,window sill,floor etc. Page-152, Item-8. NOTE Cement 0.152 cu m per100 sq.m.						m ²	1.7	38.00	64.60
	For drain	1.0	1.000	1.700		1.70				

Total- 2,532.43
 Add Contingency @ 3% 75.97
G. Total- 2,608.40
 Rate /Mtr length= 2,608.40

 Sub-Assistant Engineer
Chakdaha Municipality
 Chakdaha, Nadia

 21.12.15
 Chairman
Chakdaha Municipality
 Chakdaha, Nadia

FUND FLOW PATTERN

Rupees in lakhs

NAME OF THE SCHEME	ESTIMATED COST	YEAR 2015-16				TOTAL
		GOI	GOWB	ULB	Beneficiaries	
PMAY project - , Coopers Camp Notified Area Authority	1938.06	718.50	965.21	134.60	119.75	1938.06

PHASING OF FUND

Rupees in lakhs

YEAR 2015-16	RELEASE OF FUND				
	GOI	GOWB	ULB	Beneficiaries	TOTAL
1st Installment @ 40%	287.40	386.08	53.84	47.90	775.22
2nd Installment @ 40%	287.40	386.08	53.84	47.90	775.22
3rd Installment @ 20%	143.70	193.04	26.92	23.95	387.61
TOTAL	718.50	965.21	134.60	119.75	1938.06

REQUIREMENT OF FUND

Rupees in lakhs

SL. NO	NAME OF THE SCHEME	YEAR 2015-16	TOTAL
1	PMAY project - , Coopers Camp Notified Area Authority	1938.06	1938.06
Total		1938.06	1938.06

Abbreviation

A&OE	Administrative and Other Expenses	LIG	Low Income Group
AHP	Affordable Housing in Partnership	MD	Mission Directorate
AIP	Annual Implementation Plan	MoA	Memorandum of Agreement
BMTPC	Building Materials & Technology Promotion Council	MoHUPA	Ministry of Housing and Urban Poverty Alleviation
CDP	City Development Plan	MoU	Memorandum of Understanding
CLS	Credit linked subsidy	NA	Non Agricultural
CNA	Central Nodal Agencies	NBC	National Building Code
CPHEEO	Central Public Health and Environmental Engineering Organisation	NHB	National Housing Bank
CSMC	Central Sanctioning and Monitoring Committee	NOC	No Objection Certificate
DIPP	Department of Industrial Policy and Promotion	NPV	Net Present Value
DPR	Detailed Project Report	PLI	Primary Lending Institution
EMI	Equated Monthly Installment	RWA	Residents' Welfare Association
EWS	Economically Weaker Section	SECC	Socio Economic and Caste Census
FAR	Floor Area Ratio	SFCPoA	Slum Free City Plan of Action
FSI	Floor Space Index	SLAC	State Level Appraisal Committee
HFA	Housing for All	SLNA	State Level Nodal Agency
HFAPoA	Housing for All Plan of Action	SLSMC	State Level Sanction and Monitoring Committee
IEC	Information Education & Communication	TDR	Transfer of Development Rights
IFD	Integrated Finance Division	TPQMA	Third Party Quality Monitoring Agency
IIT	Indian Institute of Technology	ULB	Urban Local Boday
IS	Indian Standard	UT	Union Territory

Working Definitions





Affordable Housing Project:	Housing Projects where 35 % of the houses are constructed for EWS category
Beneficiary	A beneficiary family will comprise husband, wife and unmarried children. The beneficiary family should not own a pucca house (an all-weather dwelling unit) either in his//her name or in the name of any member of his/her family in any part of India
Carpet Area	Area enclosed within the walls, actual area to lay carpet. This area does not include the thickness of the inner walls.
Central Nodal Agencies	Nodal Agencies identified by Ministry for the purposes of implementation of Credit Linked subsidy component of the mission
Economically Weaker Section(EWS)	EWS households are defined as households having an annual income up to Rs 3, 00,000(Rupees Three Lakhs). States/UTs shall have the flexibility to redefine the annual income criteria as per local conditions in consultation with the Centre
EWS House	An all-weather single unit or a unit in a multi storeyed super structure having carpet area of upto 30 sq.m. With adequate basic civic services and infrastructure services like toilet , water, electricity etc. States can determine the area of EWS as per their local needs with information to Ministry
“Floor Area Ratio” (FAR)/FSI	<p>The quotient obtained by dividing the total covered area (plinth area) on all the floors by the area of the plot:</p> $\text{FAR} = \frac{\text{Total covered area on all the floors} \times 100}{\text{Plot area}}$ <p>If States/Cities have some variations in this definition, State/City definitions will be accepted under the mission</p>
Implementing Agencies	Implementing agencies are the agencies such as Urban Local Bodies, Development Authorities, and Housing Boards etc. which are selected by State Government / SLSMC for implementing Housing for All Mission.
Low Income Group (LIG)	LIG households are defined as households having an annual income between Rs.3, 00,000 (Rupees Three Lakhs One) up to Rs.6, 00,000 (Rupees Six Lakhs). States/UTs shall have the flexibility to redefine the annual income criteria as per local conditions in consultation with the Centre.
Primary Lending Institutions (PLI)	Scheduled Commercial Banks, Housing Finance Companies, Regional Rural Banks (RRBs), State Cooperative Banks, Urban Cooperative Banks or any other institutions as may be identified by the Ministry
Slum	A compact area of at least 300 populations or about 60-70 households of poorly built congested tenements, in unhygienic environment usually with inadequate infrastructure and lacking in proper sanitary and drinking water facilities.
State Land Nodal Agencies (SLNAs)	Nodal Agency designated by the State Governments for implementing the Mission
Transfer of Development Rights (TDR)	TDR means making available certain amount of additional built up area in lieu of the area relinquished or surrendered by the owner of the land, so that he can use extra built up area himself in some other land.

Beneficiary List





CHAKDAHA MUNICIPALITY

PMAY (HFA- 2022)

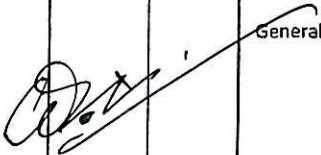
BENEFICIARY LIST OF CHAKDAHA MUNICIPALITY

Sl. No.	Name of Slum	WARD NO.	Name of Beneficiary	Father's Name / Husband's Name	Holding No.	Category					BPL/EWS	Gender	UID NO.	Photo	
						SC	ST	OBC	Minority	PH					General
1	BHABANIPUR DHAKIPARA	1	REKHA MAJHI (DAS)	BISHNU MAJHI	331	SC						BPL	Female	809085838632	
2	KBM JHILPAR SALBONI	01	AJOY ROY CHOUHURY	LT- BHABOTOSH ROY CHOUHURY	419						General		Male	553230525732	
3	PALPARA EAST	01	RITA DAS	BADAL DAS	918	SC							Female	658104522244	
4	KBM	01	BHOLANATH TALUKDAR	LT- KANAI LAL TALUKDAR	229						General	BPL	Male	301822445304	







Chairman
Chakdaha Municipality
Chakdaha, Nadia

5	PALPARA EAST	01	SANJIT KUMAR KURMI	LT- RAMPIYARY KURMI	845								Male	487172996085	
6	KBM JHILPAR SALBONI	01	SHYAMAL DEY	LT- KALIPADA DEY	411					General	24U		Male	435657011281	
7	KBM	01	SUDIP HAZRA	LT- SANTOSH HAZRA	81					General			Male	514826711586	
8	BHABANIPUR MISTRI PARA	01	JYOTIPRASAD MODAK	LT- NILKAMAL MODAK	823					General			Male	524821715314	
9	BHABANIPUR MISTRI PARA	01	ANJU KARMAKAR	SUBAL KARMAKAR	484/1					General			Female	543310087748	

Chairman
Chakdaha Municipality
Chakdaha, Nadia

10	BHABANIPUR MISTRI PARA	01	SUMITA SORAN	SINGHRAI SORAN	516	ST						Female	645612889343	
11	BHABANIPUR DHAKI PARA	01	SUJATA BHATTACHARIYA (CHAKRABORTY)	TAPASH BHATTACHARIYA	624					General		Female	790140646715	
12	PALPARA(E)	01	ASHOKE BHATTACHRYA	LT NILKAMAL BHATTACHRYA	865					General		Male	742063195778	
13	K.B.M	01	KALYANI KARMAKAR	SANAT KARMAKAR	02					General		Female	480463934926	
14	K.B.M	01	MANJU DAS	PHANIBHUSAN DAS	99	SC					SC	Female	971981706750	





 Chairman
 Chakdaha Municipality
 Chakdaha, Nadia

15	PALPARA (E)	01	DIPANKAR ADHIKARY	KALI ADHIKARY	200						General	Male	848067503213		
16	BHABANIPUR MISTRI PARA	01	SYAMAPADA BISWAS	LT- MANGAL	525						General	BPL	Male	287697634045	
17	K.B.M	01	SUSMITA DASGUPTA (DEY)	SAUMITRA	88						General	Female	349088423607		
18	BHABANIPUR DHAKI PARA	01	SUBAL BISWAS	KSHITISH BISWAS	335/2	SC						BPL	Male	732574348558	
19	BHABANIPUR DHAKIPARA	01	PURNA SARKAR	JHANTU SARKAR	565/4	SC							Male	635511397535	

Chairman

20	PALPARA (E)	01	USHA RANI KARMAKAR	PANCHANAN KARMAKAR	135							Female	337252859865	
21	KBM JHILPAR SALBONI	01	BULURANI DEY	BINAY KRISHNA	408							Female	551850206043	
22	K.B.M	01	SHIBU KARMAKAR	LT- BIMAL	10							Male	773750379109	
23	PALPARA(E)	01	BULBULI BARIK	GOUTAM	893	SC						Female	362740759323	
24	PALPARA	01	JYOTSNA ROY	LT PRAHLAD	286	SC						Female	334739700170	



Chairman
Chakdaha Municipality
Chakdaha, Nadia

25	RAJBAGAN	02	RAMESH HOWLADER	LT JAGABANDHU HOWLADER	1024	SC						Male	427969540319		
26	RAJBAGAN (S)	02	ASHA PODDAR	DIPAK PODDAR	922							BPL	Female	471753311702	
27	RAJBAGAN (S)	02	GITA SIKDAR	SITANATH SIKDAR	892	SC							Female	618349882661	
28	RAJBAGAN (N)	02	RAHUL PATRA	BALAI PATRA	1650/6								Male		
29	RAJBAGAN SRIKRISHNAPALLY	02	SUKAMAL WADDER	LT NIRMAL KANTI WADDER	1383							BPL	Male		

Chairman
Chakdaha Municipality
Chakdaha, Nadia

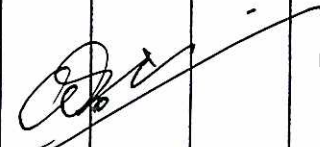
30	RAJBAGAN (N)	02	NITYANANDA MISTRY	LT HEMANTA MISTRY	1312/1	SC							Male	753113211906	
31	RAJBAGAN (S)	02	NITAI SAHA	LT MIHIR LAL SAHA	884								Male		
32	RAJBAGAN KAMAL V.P SCHOOL	02	SWAPAN KR DEY	LT NARAYAN CH DEY	1285					General	BPL	Male	419374807729		
33	RAJBAGAN SRI KRISHNA PALLY	02	SHEFALI KUNDU	ANANDA KUNDU	1371					General	BPL	Female	613028793264		
34	RAJBAGAN (N)	02	MANGAL PATRA	LT SURYAKANTA PATRA	1230	SC							Male	243956216884	





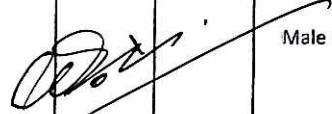

Chairman
Chakdaha Municipality
Chakdaha, Nadia

35	RAJBAGAN SRI KRISHNA PALLY	02	BIKASH DHALI	LT LALIT KR. DHALI	1346	SC							Male	411613800945	
36	RAJBAGAN SRIKRISHNA PALLT	02	ASIT BHATTACHARYA	LT SUNIL	1320						General		Male	543119980812	
37	RAJBAGAN SRI KRISHNA PALLY	02	MAYA CHATTERJEE	SANKAR	1387						General	BPL	Female	420887332039	
38	PALPARA PASCHIM	02	GOPAL SAHA	KALA CHAND	37						General		Male	821888762267	
39	PALPARA NEATAJINAGAR	02	NIRANJAN CH. BHAWAL	GOURANGA CH.	63								Male	540085909859	



 Chairman
 Chakdaha Municipality
 Chakdaha, Nadia

40	PALPARA NETAJINAGAR	02	SATYA RANJAN DHALI	LT CHANDRA KANTA	109	SC							Male	492167321921	
41	PALPARA NETAJINAGAR	02	RAMA KANTA ROY	DEBPRASAD	145/7								Male	904471887734	
42	PALPARA NETAJINAGAR	02	LITAN DAS	NITAI	145/11	SC							Male	243414951050	
43	PALPARA NETAJINAGAR	02	SUKHA RANJAN HALDER	LT GOPAL CH.	196	SC							Male	789751395008	
44	KANTHAL TALA	02	HEMANTA DAS	LT TARANI KANTA	252	SC							Male	456805383302	

Chairman
Chakdaha Municipality
Chakdaha, Nadia

45	MADHYA PALPARA	02	MANORANJAN PAL	DEBENDRA	283								Male	335201329212	
46	MADHYA PALPARA	02	GANESH PAL	NIRAPADA	286						General		Male	292156646066	
47	PALPARA PASCHIM	02	SAMAR BOSE	LT ANADI RANJAN	304						General		Male	394938111918	
48	RABINDRA NAGAR	03	GOPAL KARMAKAR	LT. RAGHU NATH	188						General		Male	510380584007	
49	RABINDRA NAGAR	03	GOPAL KARMAKAR	BHOLA NATH	411/2						General		Male	438935273716	







Chairman
Chakdaha Municipality
Chakdaha, Nadia

50	PAL BLOCK	03	KHOKON SAHA	LT SUKUMAR	142						General	Male	672633758944	
51	RABINDRA NAGAR	03	NARU GOPAL SAHA	LT. SHAMBHU	140						General	Male	982661993044	
52	RABINDRA NAGAR	03	SADHAN BISWAS	SUDHIR KR.	79/3	SC						Male	409877760586	
53	PAL BLOCK	03	BITHIKA SHIL	BHAGIRATH	215						General	Female	207709317794	
54	PAL BLOCK	03	KESHAB MONDAL	LT PRABHAT	540	SC						Male	277087355496	





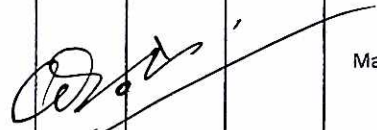

Chairman
Chakdaha Municipality
Chakdaha, Nadia

55	RABINDRA NAGAR	03	UTTAM GHOSH	LT HARIPADA	430								Male	977200244822	
56	RABINDRA NAGAR	03	SAMIR GHOSH	LT UPENDRA	370/1						General		Male	380984565160	
57	PAL BLOCK	03	KANIKA ROY	LT DINESH	587	SC							Female	707364459375	
58	RABINDRA NAGAR	03	MALATI BISWAS	SAMARENDRA	79/1	SC							Male	615876330414	
59	RABINDRA NAGAR	03	BISWAJIT ROY	LT BIDHAN CH.	739						General		Male	984637517314	







 Chairman
 Chakdaha Municipality
 Chakdaha, Nadia

60	HAMIDPUR SARKAR PARA	03	UJJAL DEY	LT MANORANJAN	419						General	Male	412116740639	
61	RABINDRA NAGAR	03	PRANOTOSH ROY	GOUTAM	670	SC						Male	522391977369	
62	RABINDRA NAGAR	03	SANJIT MONDAL	LT HARIDAS	532	SC						Male	211029800644	
63	RABINDRA NAGAR	03	RANJIT MONDAL	LT HARI DAS	532	SC						Male	701684835794	
64	PAL BLOCK	03	RABI MONDAL	LT PRABHAT MONDAL	540	SC						Male	756422907749	







Chairman
Chakdaha Municipality
Chakdaha, Nadia

65	RABINDRA NAGAR	03	RENU BALA DAS	LT ANANTA	190						General	Female	943852800707		
66	RABINDRA NAGAR	03	KUSHAL KR. DEY	LT DINESH CH.	470						General	Male	716202270968		
67	PAL BLOCK	03	LAXMAN SAHA	LT MANIK	605						General	Male	528501217433		
68	HAMIDPUR,PAL BLOCK	04	ASIT DAS	LT SATYA	76						General	BPL	Male	962951986069	
69	HAMIDPUR,PAL BLOCK	04	PIYALI DEBNATH	LT SAHADEB	144/1						General	Female	800418683071		





Chairman
Chakdaha Municipality
Chakdaha, Nadia

70	HAMIDPUR, PAL BLOCK	04	SATYADASI MAHATO	LT PURNA	156		ST					BPL	Female	364653764366	
71	PAL BLOCK	04	KALYAN KR. SAHA	LT SHIB CH. SAHA	83		OBC					BPL	Male	221311823108	
72	SUBHAS NAGAR	04	BISWANATH ROY	LT ATISH	405					General		BPL	Male	376840695460	
73	SUBHAS NAGAR	04	KAJAL DEY	LT BROJEN	484					General			Male	244119137312	
74	SUBHAS NAGAR	04	MANJU DAS	LT BINAY	394					General			Female	312098775239	

Chairman
Chakdaha Municipality
Chakdaha, Nadia

75	RAMNAGAR COLONY	04	SHEFALI MONDAL	LT GOPAL	956					General	BPL	Female	774456095022	
76	RAMNAGAR COLONY	04	ADYANATH SAHA	NARAYAN CH.	989					General	BPL	Male	440843481567	
77	RAMNAGAR COLONY	04	SUJAN SARKAR	JITEN	313	SC						Male	965907243638	
78	PAL BLOCK	04	GOUR KHAN	LT KALIPADA	29					General		Male	220044752712	
79	SUBHAS NAGAR	04	TARUN DEBNATH	LT JIBAN	314					General	118	Male	320062750794	





Chairman
Chakdaha Municipality
Chakdaha, Nadia

80	SUBHAS NAGAR	04	DILIP PAL	LT HARIPADA	455						General	Male	663106668628	
81	SUBHAS NAGAR	04	MAMONI MONDAL	BISWANATH	388						General	BPL		
82	RAMNAGAR, DEBENDRA PALLY	04	BIJAN SARKAR	LT BINAY KRISHNA	971						General	Male	316808530860	
83	SUBHAS NAGAR	04	PURNIMA MAJUMDAR	MANOJIT MAJUMDAR	208						General	BPL	705841738071	
84	SUBHAS NAGAR	04	PRATIMA DAS	NETAI	193						General	BPL	462809473480	





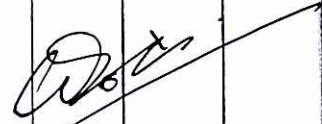

Chairman
Chakdaha Municipality
Chakdaha, Nadia

85	SUBHAS NAGAR	04	GITA BANIK	SURYA KANTA	658					General		Female	289697486010	
86	SUBHASH NAGAR	04	SHAMBU PAL	LT GOPAL PAL	192					General	BPL	Male	948384354240	
87	SUBHASH NAGAR	04	PRIYOTASH CHAKRABORTY	LT KALIPADA	533					General		Male	962040102441	
88	SUBHASH NAGAR	04	SHEFALI SAHA	LT AKHIL	757					General		Female	223560915069	
89	RABINDRA NAGAR	04	DIPUL BOSE	LT SUBODH	515					General	BPL	Male	417333304699	





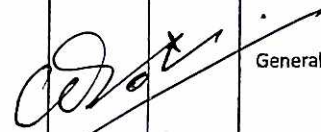

Chairman
Chakdaha Municipality
Chakdaha, Nadia

90	RAMNAGAR COLONY	04	TAPAS KR. DAS	LT NAGENDRA	873/1	SC							Male	660613611029	
91	JASHRA, MITRA PARA	05	SANJIT BAG	BISU	4/1	SC							Male	725191064144	
92	JASHRA, MITRA PARA	05	KALIDAS BISWAS	ARUN BISWAS	262	SC							Male	897106683623	
93	JASHRA, MITRA PARA	05	SANCHAYITA BISWAS	LT SWAPAN	240						General		Female	505167135926	
94	JASHRA SOUTH WEST PARA	05	FELAN BISWAS	NIKHIL	133/1	SC							Female	61449477790	







Chairman
Chakdaha Municipality
Chakdaha, Nadia

95	JASHRA ,TAL PUKUR PAR,SARDAR PARA	05	ABHIJIT ROY	TULSI	55					General	Male		
96	JASHRA ,TAL PUKUR PAR,SARDAR PARA	05	BIFAL SARDAR	LT BAHUBAL	1068		ST				Male	516373971174	
97	JASHRA ,KUMOR PARA	05	MADAN RAJBANSHI	SUNIL	517	SC					Male		
98	JASHRA KUMOR PARA	05	PADMA BARIK	ABHAY PADA	428		OBC				Female	471911755272	
99	JASHRA KUMOR PARA	05	PRIYANKA BARIK	SUSHIL	419/1					General	Female	783579558230	



Charman
Chakdaha Municipality
Chakdaha, Nadia

100	JASHRA RAJBANSHI PARA	05	SHYAMNATABAR RAJBANSHI	RADHA GOBINDA	539	SC							Male	641247242939	
101	JASHRA MASTER PARA	05	KANAN ADHIKARY	ADHIR	885						General		Female	326077175051	
102	JASHRA MADHYA PARA	05	PARBATI HALDER	SWAPAN	859	SC						BPL	Female	936904303211	
103	JASHRA MADHYA PARA	05	SOUBHAGYA BISWAS	LT NABA KR.	856	SC						BPL	Male	713771123159	
104	JASHRA MADHYA PARA	05	BEBI SANTRA	LT MINTU	1125	SC							Female	689547889649	

 Chairman
 Chakdaha Municipality
 Chakdaha, Nadia

105	JASHRA ADIBASI PARA	05	SUKUL HANSDA	DHIREN	98	ST						Male	204368303522	
106	JASHRA ADIBASI PARA	05	BIMAL MANDI	LT MANIK	122	ST						Male	442996703649	
107	JASHRA GOSAI COLONY	05	AJIT BISWAS	LT GAKUL	622					General		Male	217280257744	
108	JASHRA GOSAI COLONY	05	PINTU SINGHA	LT BALARAM	813	SC						Male	834713750070	
109	JASHRA GOSAI COLONY	05	PUTUL RAJBANSHI	TAPAN	826	SC						Female	649676448202	







Chairman
Chakdaha Municipality
Chakdaha, Nadia

110	JASHRA NAMASUDRA PARA	05	SUDHA RANI ADHIKARY	LT SWAPAN	664						General	Female	852544258991	
111	JASHRA NAMASUDRA PARA	05	MALI BISWAS	LT PRANAB	669	SC						Female	94487666865	
112	JASHRA BISWAS PARA	05	BIRENDRA NATH SEN	LT KALI PADA	567						General	Male	679002208818	
113	JASHRA BISWAS PARA	05	BISWAJIT MONDAL	SADHAN	588						General	Male	284599252647	
114	JASHRA NAMASUDRA PARA	05	ANANDA MOHAN SARKAR	RAMESH	744	SC						Male	605240777065	

(Signature)
Chairman
Chakdaha Municipality
Chakdaha, Nadia

115	JASHRA GOSAI COLONY	05	BASANTI PARUI	LT SHANKAR	823	SC							Female	251352455737	
116	JASHRA KUMOR PARA	05	TANMAY CHATTERJEE	LT DILIP	407						General		Male	764689044574	
117	JASHRA KUMOR PARA	05	MANOJ HALDER	BHUPATI	499	SC							Male	537942744548	
118	JASHRA BISWAS PARA	05	JADAB MONDAL	LT MANMATHA	670	SC							Male	719013933713	
119	3 NO DURGANAGAR	06	SANDHYA PAL	LT- KACTICK	850						General	BPL	Female	806752683417	





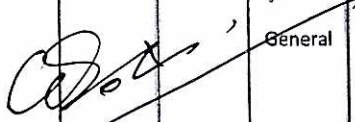

Chairman
Cnakhaha Municipality
Chekhaha, Nadia

120	3 NO DURGANAGAR	06	ANIMA KIRTANYA	NIKUNJA	963						General	Female	321622470040		
121	3 NO DURGANAGAR	06	HEMLAL SARKAR	RAMKRISHNA	904	SC						Male	235016338527		
122	3 NO DURGANAGAR	06	SHEFALI DAS	LT- MAHANANDA	936						General	BPL	Female	279547002093	
123	NATUNPARA	06	PARTHA MUHURI	SANTOSH	358						General	BPL	Male	210964554757	
124	NATUNPARA	06	PRABIR SHIL	LT- MANORANJAN	354						General	BPL	Male	649317612266	

 Chairman
 Chakdaha Municipality
 Chakdaha, Nadia

125	NATUNPARA	06	MIHIR CHAKRAPANI	LT- NONI	288/1						General	Male	394401231922		
126	NATUNPARA	06	AMALKRISHNA MUKHERJEE	PHANIBHUSAN	277						General	BPL	Male	630167434479	
127	SADHANPALLY	06	FELAN BISWAS	KHOKA	468	SC						BPL	Male	784796163328	
128	3 NO DURGANAGAR	06	BDISHITHA MALI	GOUR	198/25	SC						BPL	Male	605041102222	
129	3 NO DURGANAGAR	06	GOPEN DEBNATH	MAHADEB	95						OBC		Male	861747754308	



 Chairman
 Chakdaha Municipality
 Chakdaha, Nadia

130	3 NO DURGANAGAR	06	SHEFALI GOSWAMI	LT- SHAMBHU NATH	82						General	BPL	Female		
131	3 NO DURGANAGAR	06	SAMIR RUDRA	LT- NAKUL RUDRA	787						General	BPL	Male	817627852718	
132	3 NO DURGANAGAR	06	JAYGOPAL MONDAL	LT- RENUPADA	612	SC							Male	708887939407	
133	3 NO DURGANAGAR	06	KHUSHI ADHIKARI	KESHTO	535						General		Female	949439962396	
134	3 NO DURGANAGAR	06	SUBAL SAHA	SHANTIGOPAL	771						General	BPL	Male	638652212763	



Chairman
Chakdaha Municipality
Chakdaha, Nadia

135	3 NO DURGANAGAR	06	ANJALI KARMAKAR	RAMKRISHNA	156					General	Female	634394763164		
136	3 NO DURGANAGAR	06	BADAL MONDAL	RADHESHYAM	607/1					General	Male	828656108303		
137	3 NO DURGANAGAR	06	SHOBHA HALDER	LT- PROFULLA	947	SC					41	Female	618079794372	
138	3 NO DURGANAGAR	06	SHYAMAL DUTTA	SUDHIR	100					General	Male	294599871561		
139	DURGA NAGAR NATAJI COLONY	07	RABINDRA NATH SAHA	LT SUDGIR	762					General	Male	319335457522		





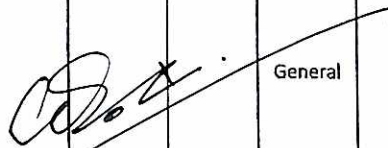

Chairman
Chakdaha Municipality
Chakdaha, Nadia

140	DURGA NAGAR HATHATH COLONY	07	MIRA SHIL	ADHIR	838						General	BPL	Female	350102473419	
141	DURGA NAGAR NATAJI COLONY	07	PARBATI SARDAR	LT NARAYAN	719						General	BPL	Female	800009854118	
142	DURGANAGAR HATATH NAGAR	07	SUBAL MANDAL	LT JAGADISH	638						General	BPL	Male	987021604884	
143	DURGANAGAR HATATH NAGAR	07	PADMARANI SAHA	LT KHAGEN SAHA	626						General	BPL	Female	650771012543	
144	DURGANAGAR HATATH NAGAR	07	MIRA GHOSH	LT KHOKON	649						General		Female	971223491790	







Chairman
Chakdaha Municipality
Chakdaha, Nadia

145	DURGANAGAR HATATH COLONY	07	PALASI DHAR	LT SURESH	627					General	BPL	Female	780030658121	
146	DURGANAGAR HATATH COLONY	07	DIPALI SARKAR	KRIPASINOHU	633					General		Female	329763674830	
147	DURGANAGAR HATATH COLONY	07	SACHIN SARDAR	LT GANESH	643					General		Male	568550760465	
148	DURGANAGAR HATATH COLONY	07	SUCHITRA DAS	LT RAMESH	642					General	BPL	Female	307692876255	
149	DURGANAGAR HATATH COLONY	07	ASHA SARDAR	TARIEN	641					General		Female	547364014218	

Chairman
Chakdaha Municipality
Chakdaha, Nadia

150	DURGA NAGAR	07	SANJIB DEBNATH	LT BINOY	440						General	BPL	Male	426949337707	
151	DURGA NAGAR BATH TALA	07	MANORANJAN DAS	LT RAMONI DAS	363						General		Male	811929435667	
152	DURGA NAGAR BATH TALA	07	ARUN CHATERJEE	LT PARITOSH	409						General		Male	265715806737	
153	DURGA NAGAR NETAJI COLONY	07	BALAI MAJUMDER	LT SHOBHA	759						General		Male	490757182130	
154	DURGA NAGAR	07	SANJIB DUTTA	LT BISEANATH	550/1						General	BPL	Male	357145412719	

 Chairman
 Chakdaha Municipality
 Chakdaha, Nadia

155	NARANDRA PALLY	07	NANI GOPAL KARMAKAR	LT UPENDRA NATAH	501						General	Male	586715513847	
156	DURGA NAGAR HATATH COLONY	07	ANJALI BAG	SWAPAN	651						General	Female	683768232996	
157	DURGA NAGAR	07	DIBAS SEN	LT CHITTARANJAN	704						General	Male	234692298957	
158	DURGA NAGAR NATUN COLONY	07	KANAI SARDAR	LT PADA	645						General	Male	967493174054	
159	DURGA NAGAR GHOSH PARA	07	UMA DEBNATH	LT SUNIL	169						General	Female	280618938086	

Chairman
Chakdaha Municipality
Chakdaha, Nadia