

- NOTE:-
1. ALL WINDOW OPENINGS (W1&W2) WILL BE PROVIDED WITH Z-BATTEN SHUTTERS.
 2. ALL DOORS (D1&D2) -25TH Z-BATTEN SHUTTERS, SINGLE LEAF.
 3. WO2 - OPENING PROVIDED WITH R.C.C. JALLI.
 4. PLINTH HEIGHT - 450 TH.
 5. CEILING HEIGHT - 2750 TH.
 6. MAIN WALL - 250 TH.
 7. PARTITION WALL - 125 TH.
 8. ROOF SLAB, BEAM, LINTEL, ETC. WITH REINFORCED CEMENT CONCRETE M20 GRADE.
 9. FLOOR OF VERANDAH, WC, BATH, & KITCHEN ROOM TO BE KEPT 15 MM BELOW THE FLOOR LEVEL OF ROOM & PASSAGE.
 10. 100 MM TH. PIECE LINTEL OVER OPENING HAVE BEEN PROVIDED.
 11. ALL DIMENSION ARE IN MM.

DOORS & WINDOWS SCHEDULE	
MARKING	DIMENSION
W1	900 X 900
W2	750 X 900
WO2	750 X 750
D1	900 X 2100
D2	750 X 2100

FLOOR AREA - 25.37 SQM.
 BUILT UP AREA - 32.18 SQM.

FOUNDATION DETAILS

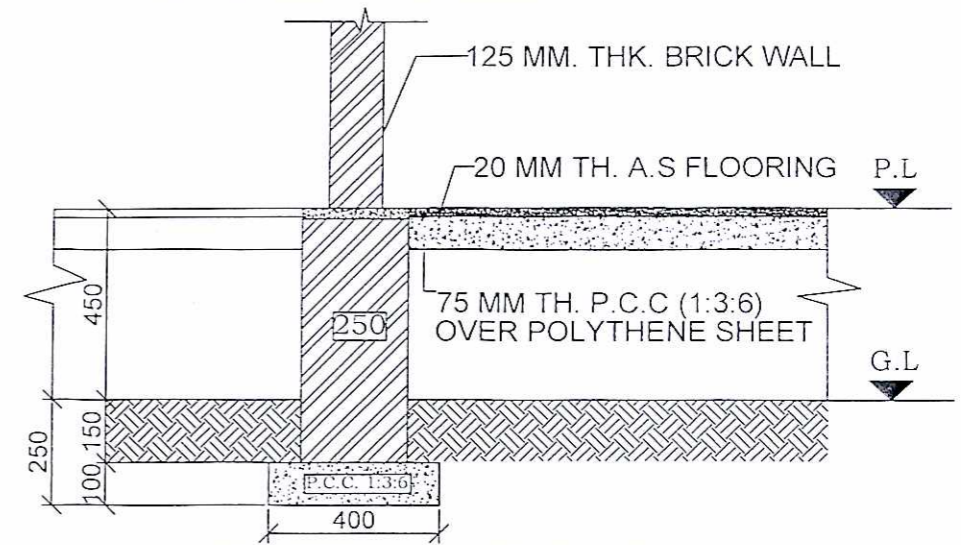

125 MM THK. BRICK WALL

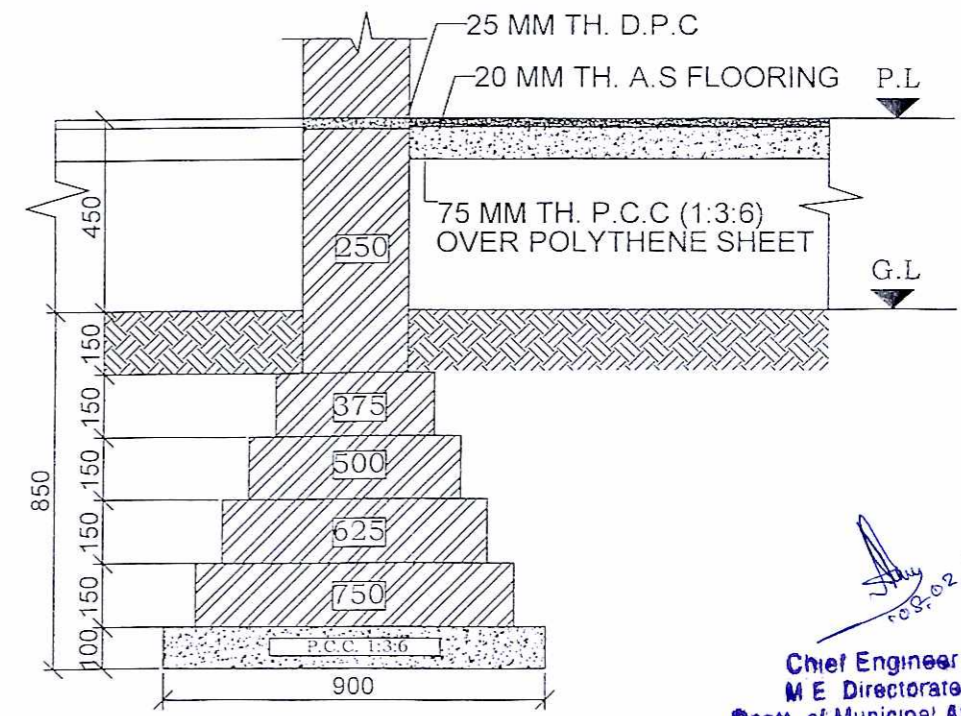

250 MM THK. BRICK WALL

(Signature)
 Chief Engineer
 M E Directorate
 Deptt. of Municipal Affairs
 Govt. of West Bengal

PRADHAN MANTRI AWAS YOJANA
 HOUSING FOR ALL (URBAN)

OFFICE OF THE CHIEF ENGINEER
 MUNICIPAL ENGINEERING DIRECTORATE
 GOVT. OF WEST BENGAL

DWG. NO. *(Signature)* SCALE :- 1:50 & 1:25