



রাজ্য নগর উন্নয়ন সংস্থা



STATE URBAN DEVELOPMENT AGENCY

“ইলগাস ভবন”, এইচসি ব্লক, সেক্টর-৩, বিধাননগর, কলকাতা-৭০০ ১০৬, পশ্চিমবঙ্গ

“ILGUS BHAVAN”, HC Block, Sector - III, Bidhannagar, Kolkata - 700 106, West Bengal

SUDA- 110/16/2022

21.09.2020

Memorandum

Release of fund for O&M cost of shelter for Urban Homeless under DAY-NULM

Funds shown herein are being released electronically in favour of ULBs mentioned in next pages for ‘O&M cost’ of shelter for urban homeless under DAY-NULM.

Utilisation Certificate of the funds received from SUDA may please be sent to this office and uploaded at sudawb.org →e-services positively within 60 days.

Finance Officer, SUDA

দূরভাষ : ২৩৫৮ ৬৪০৩ / ৫৭৬৭, ফ্যাক্স : ২৩৫৮ ৫৮০০

Tel : 2358 6403/5767, Fax : 2358 5800, E-mail : wbsudadir@gmail.com

Account Section : 2358 6408

SL NO	ULB NAME	PERIOD OF FUND DISBURSED	FUND RELEASED
1	BONGAON	Nov'19 to Dec'19 + July'20 to September'20	250000
2	ENGLISH BAZAR	July'20 to September'20	109923
3	Habra	July'20 to September'20	100124
4	Nabadwip	July'20 to September'20	81696
5	CHANDERNAGORE MC	July'20 to September'20	72010

Copy for information to:

1. Board of Administrator/Finance Officer of Bongaon / English Bazar / Habra / Nabadwip / Chandernagore MC/ Municipality.

He/she is requested to verify that the respective Account of NULM of the ULB has duly been credited with the sanctioned allotment. For any discrepancy, he/she is requested to report the same immediately to SUDA.

2. SMM, S&SI, NULM.

Finance Officer, SUDA

Note No. #1

Sub: Release of fund (final installment) for construction of Boundary Wall of SUH-Habra under the scheme shelter for Urban Homeless (SUH) under DAY-NULM at Habra Municipality

It may be mentioned that a proposal for **construction of Boundary Wall of SUH** of SUH at Habra Municipality was sanctioned as per post facto approval of Project Sanction Committee with a sanctioned cost of **Rs. 573406.00** in favour of Habra Municipality On 29.08.2019 (copy placed in the C.P. side for your kind perusal). As per administrative approval & financial sanction, 50% fund (1 st installment) has been released after issuance of work order for the aforesaid work.

Now the ULB has completed the construction of Boundary Wall of SUH. A completion certificate with a completion value has been submitted by the ULB which is signed by Executive Engineer, MED, North 24 PS Division. Also concerned ULB submitted the UC of 1 st installment for construction of Boundary Wall of SUH in GFR-12C format duly signed by the Chairperson, BOA, Habra Municipality, FO, Habra Municipality and Executive Engineer, MED, North 24 PS Division. A fund requisition for the remaining fund for the same is submitted by the concerned ULB.

Now fund amounting of **Rs. 2.13 Lakh (Central 1.27 Lakh State:0.86 Lakh)** may be released in favour of Habra Municipality as 2 nd installment for the settlement of the bills for the aforementioned purpose.

Submitted for your kind perusal.

14/09/2020 1:58 PM

SOUMEN DE
(SMM-WBSULM(NULM)(SUDA))

Note No. #2

A fund amounting to **Rs. 2.13 Lakh (Central 1.27 Lakh State:0.86 Lakh)** may be released in favour of Habra Municipality as 2 nd installment and for the settlement of the bills for the construction of Boundary Wall of SUHs. All previous UCs and work completion certificate given.

17/09/2020 10:50 PM

SHAON SEN
(AD DIR(SUDA))

Note No. #3

As proposed.

18/09/2020 11:37 AM

SANTANU MUKHERJEE
(DIR(SUDA))

Note No. #4

FO may kindly release fund

18/09/2020 1:06 PM

SHAON SEN
(AD DIR(SUDA))

Note No. #5

Please process.

18/09/2020 3:06 PM

GOUTAM HORE
(FO(ACCT)(SUDA))



HABRA MUNICIPALITY

(ESTD.-1979)

POURA BHAWAN

PROMODE DASGUPTA SARANI, P.O. HIJALPUKURIA, NORTH 24 PARGANAS, PIN - 743271
email : habramunicipality@yahoo.com

Ref. No. HM/1158/NU.M/2020

Date 04/08/2020

To
The Director, SUDA & Mission Director, WBSULM
ILGUS Bhawan, HC - Block,
Sector III, Bidhannagar,
Kolkata 700106



S. Sen (AD)
Pl.
5.9.2020

Sub: Submission of Completion Certificate and requisition of 2nd instalment of fund for construction of boundary wall of 50 Bedded Shelter for Urban Homeless.

Ref: SUDA-118/16/6181 dated:29/08/2019

Sir,

With reference to the above, this is to certify that construction of boundary wall of 50 bedded Shelter for Urban Homeless at banipur ward no.22 under Habra Municipality has been successfully completed. We are hereby submitting the completion certificate for the same.

In reference to the above this is to inform you that total vetted estimate of the same was Rs. 5, 73,406.00(Rupees five lakh seventy three thousand four hundred and six) only. Out of which we have received a fund of Rs. 2, 86,000.00(Rupees two lakh eighty six thousand)only as the first instalment vide your letter no. **SUDA-118/16/7892 dated: 11/12/2019.**

Therefore, I request you to kindly release the second and final instalment of fund so that we can release the payment and provide final utilization certificate respectively.

Thanking You

Yours Faithfully

Chairperson
Board of Administrators
Habra Municipality

Chairperson
Board of Administrators
Habra Municipality

[Handwritten signature]



Government of West Bengal
Office of the Executive Engineer, North 24-Parganas Division,
Municipal Engineering Directorate
7, K.B. Bose Rd. (2nd floor) Barasat, North 24-Pgs
Kolkata-700 124
Phone No.:- (033) 2584-4288
Email :- north24pgsdivisionmeda@gmail.com

No. : MED/PRG-1/

/1N-08/16

Date:- 04.09.2020

To
The Superintending Engineer (East Circle)
M.E.Dte
AB - 30/1, Prafullya Kanan (West)
Krishnapur, Baguiati
Kolkata – 700101

Sub : Submission of Completion Certificate for construction of Boundary Wall of 50 bedded, 4 storied Shelter for Urban Homeless under DAY-NULM for the town **Habra** under the jurisdiction of North 24-Parganas Division.

Ref. : Chairman's office memo no. HM/1109/NULAM/2020, Dt. 28.08.2020

Sir,

Enclosed please find herewith the Completion Certificate in duplicate for construction of Boundary Wall of 50 bedded, 4 storied Shelter for Urban Homeless under Deendayal Antyodaya Yojana – National Urban Livelihoods Mission (DAY-NULM) at ward no. 22 as submitted by the Chairman, Habra Municipality and duly checked by this end for favour of your kind information and taking necessary action.

Thanking you,
Encl. : As stated

Yours faithfully,

Executive Engineer
North 24-Pgs. Division, M.E.Dte.

No. : MED/PRG-1/ 1891(2) /1N-08/16

Date:- 04.09.2020

Copy forwarded for information along with a copy of UC to :

- 1) The Chairman, Habra Municipality– along with a copy of C.C.
- 2) The Mission Director, WBSULM & SUDA, Ilgus Bhavan, Salt Lake City, Kolkata
- 3) The Chif Engineer, M.E.Dte. Bikash Bhavan(1st floor), kol-700091.

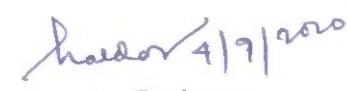

Executive Engineer,
North 24-Pgs. Division, M.E.Dte.
Municipal Engineering Directorate
Deptt. of U.D. & M.A.
Government of West Bengal

TO WHOM IT MAY CONCERN

Project Name	Approved Project Cost	Work-order Amount	Total Completed Cost	Date of Completion
Construction of Boundary Wall for SUH at Habra	Rs. 5,73,406.00 (Rupees five lakh seventy three thousand four hundred and six) only	Rs. 5,55,584.00 (Rupees five lakh fifty five thousand five hundred eighty four)only	Rs. 4,99,000.00 (Rupees four lakh ninety nine thousand)only	14/02/2020

This is to certify that the above mentioned project sanctioned in the financial year 2019-20 of Habra Municipality under DAY-NULM scheme completed in all respect.



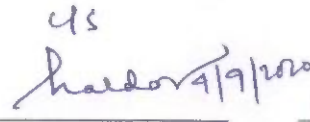

45

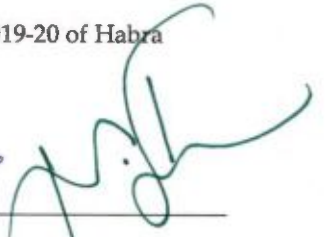

Sub-Assistant Engineer
Habra Municipality
Sub-Assistant Engineer
HABRA MUNICIPALITY

Assistant Engineer,
ME Dte., North 24 Parganas
Div., Barasat
Assistant Engineer (Civil)
North 24 Parganas Division
Municipal Engineering Directorate
Dept. of U.D. & M.A.
Government of West Bengal

Executive Engineer,
ME Dte., North 24 Parganas
Div., Barasat
Executive Engineer
North 24- Parganas Division
Municipal Engineering Directorate
Dept. of U.D. & M.A.
Government of West Bengal /

Chairperson
Board of Administrators,
Habra Municipality
Chairperson
Board of Administrators
Habra Municipality



Government of West Bengal
Office of the Executive Engineer, North 24-Parganas Division,
Municipal Engineering Directorate
7, K.B. Bose Rd. (2nd floor) Barasat, North 24-Pgs
Kolkata-700 124
Phone No.:- (033) 2584-4288
Email :- north24pgsdivisionmed@gmail.com

Soumitra SMM -
19/8/20

No. : MED/PRG-1/

/1N-08/16

Date:- 19.08.2020

To
The Superintending Engineer (East Circle)
M.E.Dte
AB - 30/1, Prafulla Kanan (West)
Krishnapur, Baguiati
Kolkata - 700101



S. Sen, AD
Pl. 19.8.2020

Sub : Submission of Utilisation Certificate for construction of Boundary Wall of 50 bedded, 4 storied Shelter for Urban Homeless under DAY-NULM for the town **Habra** under the jurisdiction of North 24-Parganas Division.

Ref. : Chairman's office memo no. HM/1004/NULAM/2020, Dt. 18.08.2020

Sir,

Enclosed please find herewith the Utilisation Certificate in duplicate for construction of Boundary Wall of 50 bedded, 4 storied Shelter for Urban Homeless under Deendayal Antyodaya Yojana – National Urban Livelihoods Mission (DAY-NULM) at ward no. 22 as submitted by the Chairman, Habra Municipality and duly checked by this end for favour of your kind information and taking necessary action.

Thanking you,

Enclo. : As stated

Yours faithfully,

Executive Engineer
North 24-Pgs. Division, M.E.Dte.

No. : MED/PRG-1/ **1649 (3)** /1N-08/16

Date:- 19.08.2020

Copy forwarded for information along with a copy of UC to :

- 1) The Chairman, Habra Municipality– along with a copy of U.C.
- 2) The Mission Director, WBSULM & SUDA, Ilgus Bhavan, Salt Lake City, Kolkata
- 3) The Chief Engineer, M.E.Dte. Bikash Bhavan (1st floor), kol-700091.

19/8/20

Executive Engineer
North 24-Pgs. Division, M.E.Dte.

GFR 12 -C
[[See Rule 239]]

UTILIZATION CERTIFICATE
(Where expenditure incurred by Govt. bodies only)

For Construction of Boundary Wall of SUH for the F.Y. 19-20

Sl. No.	Letter No. and date	Amounts Rs.	
1.	SUDA-118/16/7892 dated 11/12/2019	2,86,000.00	Certified that out of Rs. 2,86,000 (Rupees two lakh eighty six thousand only) of grant sanctioned during the year 2019-20 in favour of Habra Municipality North 24 Parganas Letter No. given in the margin and NIL on account of unspent balance of previous year, a sum of Rupees 2,86,000 (Rupees two lakh eighty six thousand only) has been utilized for the purpose of Construction of Boundary Wall of SUH for which it was sanctioned and that the balance of Rs. NIL remaining unutilized at the end of the year will be adjusted/utilized in next year.
	Total	2,86,000.00	

2. Certified that I have satisfied myself that the conditions on which the grants-in-aid was sanctioned have been duly fulfilled and that I have exercised the following checks to see that the money was actually utilized for the propose for which it was sanctioned.

Kinds of checks exercised:

Examination of 1. Vouchers, 2. Cash Book, 3. Ledger, 4. Statement of Expenditure & 5. Statement of Fund Position



Signature of Accountant (DAY-NULM),
Habra Municipality
Accountant
DAY-NULM, HABRA MUNICIPALITY

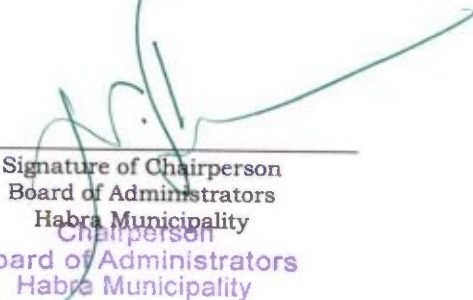

Signature of Chairperson
Board of Administrators
Habra Municipality
Chairperson
Board of Administrators
Habra Municipality



Signature of Finance Officer
Habra Municipality
FINANCE OFFICER
HABRA MUNICIPALITY

CPS
Haldar 19/8/20
Executive Engineer
North 24 Parganas Division

Signature of Executive Engineer
Municipal Engineering Directorate
M.E. Dte., North 24 Parganas Division, Barasat
Deptt. of U.D. & M.A.
Government of West Bengal

GFR 12 -C
[(See Rule 239)]

UTILIZATION CERTIFICATE
(Where expenditure incurred by Govt. bodies only)

For Construction of Boundary Wall of SUH for the F.Y. 19-20

Sl. No.	Letter No. and date	Amounts Rs.	
1.	SUDA-118/16/7892 dated 11/12/2019	2,86,000.00	Certified that out of Rs. 2,86,000 (Rupees two lakh eighty six thousand only) of grant sanctioned during the year 2019-20 in favour of Habra Municipality North 24 Parganas Letter No. given in the margin and NIL on account of unspent balance of previous year, a sum of Rupees 2,86,000 (Rupees two lakh eighty six thousand only) has been utilized for the purpose of Construction of Boundary Wall of SUH for which it was sanctioned and that the balance of Rs. NIL remaining unutilized at the end of the year will be adjusted/utilized in next year.
	Total	2,86,000.00	

2. Certified that I have satisfied myself that the conditions on which the grants-in-aid was sanctioned have been duly fulfilled and that I have exercised the following checks to see that the money was actually utilized for the propose for which it was sanctioned.

Kinds of checks exercised:

Examination of 1. Vouchers, 2. Cash Book, 3. Ledger, 4. Statement of Expenditure & 5. Statement of Fund Position

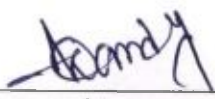

Signature of Accountant (DAY-NULM),
Habra Municipality
Accountant
DAY-NULM, HABRA MUNICIPALITY



Signature of Chairperson
Board of Administrators
Habra Municipality
Chairperson
Board of Administrators
Habra Municipality



Signature of Finance Officer
Habra Municipality
FINANCE OFFICER
HABRA MUNICIPALITY

CS

Signature of Executive Engineer,
North 24 Parganas Municipality
Municipal Engineering Division, Barasat
Deptt. of U.D. & M.A.
Government of West Bengal



Government of West Bengal
Office of the Executive Engineer, North 24-Parganas Division,

Municipal Engineering Directorate
7, K.B. Bose Rd. (2nd floor) Barasat, North 24-Pgs
Kolkata-700 124

Phone No.:- (033) 2584-4288

Email :- north24pgsdivisionmed@gmail.com

No. : MED/PRG-1/

/1N-08/16

To

The Superintending Engineer (East Circle)

M.E.Dte

AB - 30/1, Prafullya Kanan (West)

Krishnapur, Baguiati

Kolkata - 700101



Date:-

S. Sen (AD)

Pl.

5.9.2020

Sub : Submission of Utilisation Certificate for construction of 50 bedded, 4 storied Shelter for Urban Homeless under DAY-NULM for the town **Habra** under the jurisdiction of North 24-Parganas Division.

Ref. : Chairman's office memo no. HM/0879/NULAM/2020, Dt. 06.08.2020

Sir,

Enclosed please find herewith the Utilisation Certificate in duplicate for construction of 50 bedded, 4 storied Shelter for Urban Homeless under Deendayal Antyodaya Yojana – National Urban Livelihoods Mission (DAY-NULM) at ward no. 22 as submitted by the Chairman, Habra Municipality and duly checked by this end for favour of your kind information and taking necessary action.

Thanking you,

Enclo. : As stated

Yours faithfully,

Executive Engineer
North 24-Pgs. Division, M.E.Dte.

No. : MED/PRG-1/1632 (2) /1N-08/16

Date:- 12.08.2020

Copy forwarded for information along with a copy of UC to :

- 1) The Chairman, Habra Municipality– along with a copy of U.C.
- 2) The Director, SUDA, Ilgus Bhavan, Salt Lake City, Kolkata
- 3) The Chif Engineer, M.E.Dte. Bikash Bhavan(1st floor), kol-700091.

Executive Engineer
North 24-Pgs. Division, M.E.Dte.

GFR 12 -C
[(See Rule 239)]

UTILIZATION CERTIFICATE
(Where expenditure incurred by Govt. bodies only)

For Construction of SUH for the F.Y. 20-21

Sl. No.	Letter No. and date	Amounts Rs.	
1.	SUDA-23/2014(Pt.)/1048 dated: 19/07/2016	48,90,000	Certified that out of Rs. 1,22,27,000 (Rupees One crore twenty two lakh twenty seven thousand) only of grant sanctioned during the year 2016 -17, 2017-18 & 2018-19 in favour of Habra Municipality North 24 Parganas Letter No. given in the margin and NIL on account of unspent balance of previous year, a sum of Rs.1,06,07,948.90 (Rupees One crore six lakh seven thousand nine hundred forty eight and ninety paise) only has been utilized for the purpose of Construction of SUH for which it was sanctioned and that the balance of Rs. 16,19,051.10 (Rupees Sixteen lakh nineteen thousand fifty one and ten paise) only remaining unutilized at the end of the year will be adjusted/utilized in next year.
2.	SUDA-23/2014(pt - II)/1425 dated: 04/12/2018	48,90,000	
3.	SUDA-23/2014(pt-II)/6354 dated: 09/09/2019	24,47,000	
	Total	1,22,27,000	

2. Certified that I have satisfied myself that the conditions on which the grants-in-aid was sanctioned have been duly fulfilled and that I have exercised the following checks to see that the money was actually utilized for the propose for which it was sanctioned.

Kinds of checks exercised:

Examination of 1. Vouchers, 2. Cash Book, 3. Ledger, 4. Statement of Expenditure & 5. Statement of Fund Position



Signature of Accountant (DAY-NULM),
Habra Municipality
Accountant
DAY-NULM, HABRA MUNICIPALITY



Signature of Chairperson
Board of Administrators
Habra Municipality
Chairperson
Board of Administrators
Habra Municipality



Signature of Finance Officer
Habra Municipality
Finance Officer
Habra Municipality

CS

Executive Engineer
Signature of Executive Engineer,
North 24 Parganas Division,
M.E. Dte., North 24 Parganas Division, Barasat
Municipal Engineering Directorate
Deptt. of U.D. & M.A.
Government of West Bengal

GFR 12 -C
[(See Rule 239)]

UTILIZATION CERTIFICATE
(Where expenditure incurred by Govt. bodies only)

For Construction of SUH for the F.Y. 20-21

Sl. No.	Letter No. and date	Amounts Rs.	
1.	SUDA-23/2014(Pt.)/1048 dated: 19/07/2016	48,90,000	Certified that out of Rs. 1,22,27,000 (Rupees One crore twenty two lakh twenty seven thousand) only of grant sanctioned during the year 2016 -17, 2017-18 & 2018-19 in favour of Habra Municipality North 24 Parganas Letter No. given in the margin and NIL on account of unspent balance of previous year, a sum of Rs.1,06,07,948.90 (Rupees One crore six lakh seven thousand nine hundred forty eight and ninety paisa) only has been utilized for the purpose of Construction of SUH for which it was sanctioned and that the balance of Rs. 16,19,051.10 (Rupees Sixteen lakh nineteen thousand fifty one and ten paisa) only remaining unutilized at the end of the year will be adjusted/utilized in next year.
2.	SUDA-23/2014(pt - II)/1425 dated: 04/12/2018	48,90,000	
3.	SUDA-23/2014(pt-II)/6354 dated: 09/09/2019	24,47,000	
	Total	1,22,27,000	

2. Certified that I have satisfied myself that the conditions on which the grants-in-aid was sanctioned have been duly fulfilled and that I have exercised the following checks to see that the money was actually utilized for the propose for which it was sanctioned.

Kinds of checks exercised:

Examination of 1. Vouchers, 2. Cash Book, 3. Ledger, 4. Statement of Expenditure & 5. Statement of Fund Position

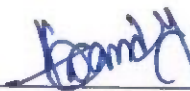

Signature of Accountant (DAY-NULM),
Habra Municipality
Accountant
DAY-NULM, HABRA MUNICIPALITY

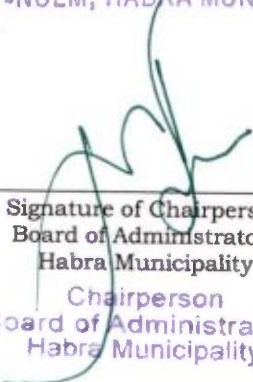

Signature of Chairperson
Board of Administrators
Habra Municipality
Chairperson
Board of Administrators
Habra Municipality



Signature of Finance Officer
Habra Municipality
Finance Officer
Habra Municipality

cls

Signature of Executive Engineer,
North 24 Parganas Division, Barasat
Municipal Engineering Directorate
Deptt. of U.D. & M.A.
Government of West Bengal

3/12/20
12/8/20

WEST BENGAL STATE URBAN LIVELIHOOD MISSION

(Under Municipal Affairs Department, Government of West Bengal)

"ইলগাস ভবন", এইচ-সি ব্লক, সেকটর-৩, বিধাননগর, কলকাতা ৭০০ ১০৬, পশ্চিমবঙ্গ।

"ILGUS BHAVAN", H-C Block, Sector-III, Bidhannagar, Kolkata 700 106, West Bengal.

SUDA-118/16/৯৯৪৫

Date:16/03/2020

Memorandum

Release of fund for O&M cost of shelter for Urban Homeless under DAY-NULM

Funds shown herein are being released electronically in favour of ULBs mentioned in next pages for 'O&M cost' of shelter for urban homeless under DAY-NULM.

Utilisation Certificate of the funds received from SUDA may please be sent to this office and uploaded at sudawb.org → e-services positively within 60 days.

Finance Officer, SUDA

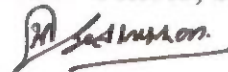

দুরভাষ: ২৩৫৮ ৬৪০৩/৬৪২১/৫৭৬৭, ফ্যাক্স : ২৩৫৮৫৮০০

Tel: 2358-6403/6421/5767, Fax: 2358-5800, E-Mail: wbsulm@gmail.com

Sl	Name of Payee	SUH Name
1	Habra Municipality	VIVEKANANDA B
2	Arambag Municipality	BHOBOGHURE B
3	Jiaganj Azimganj Municipality	VALOBASA

SUDA-118/16/9985/1(2)

16.03.2020

Copy for information to:

1. Chairman / Executive Officer of Habra / Arambag / Jiaganj Azimganj Municipality.

He/she is requested to verify that the respective Account of NULM of the ULB has duly been credited with the sanctioned allotment. For any discrepancy, he/she is requested to report the same immediately to SUDA.

2. SMM, S&SI, NULM.



Finance Officer, SUDA

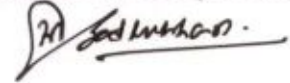



রাজ্য নগর উন্নয়ন সংস্থা

STATE URBAN DEVELOPMENT AGENCY

“ইলগাস ভবন”, এইচসি ব্লক, সেক্টর-৩, বিধাননগর, কলকাতা-৭০০ ১০৬, পশ্চিমবঙ্গ

“ILGUS BHAVAN”, HC Block, Sector - III, Bidhannagar, Kolkata - 700 106, West Bengal

SUDA-118/16/১১১৭

12.03.2020

From : Director, SUDA

To : The Manager,
State Bank of India,
Salt Lake City, Kolkata - 700 091.

**Sub: Electronic Transfer of Fund debiting this office
Current Account No. 37715094723.**

O&M cost of SUH under NULM

Sir,

You are requested to kindly arrange for electronic transfer of funds as per details given in pages 02 debiting the amounts from this office Current Account No. 37715094723 lying with your branch in respect of O&M cost of SUH under NULM.

(Petrus Anuranjan Soreng)
Finance Officer
SUDA

(Goutam Hore)
Finance Officer
SUDA

দূরভাষ : ২৩৫৮ ৬৪০৩ / ৫৭৬৭, ফ্যাক্স : ২৩৫৮ ৫৮০০

Tel : 2358 6403/5767, Fax : 2358 5800, E-mail : wbsudadir@gmail.com

Account Section : 2358 6408

Sl	Name of Payee	Amount (In Rs.)	Name of the Bank	Branch Name	Account No.	IFS Code
1	Habra Municipality	277,491.00	State Bank of India	Banipur	35156397259	SBIN0016644
2	Arambag Municipality DAY NATIONAL URBAN LIVELIHOOD MISSION	193,010.00	State Bank of India	ARAMBAGH ADB GORHATI MORE	35920216448	SBIN0001744
3	Jiaganj Azimganj Municipality	144,123.00	State Bank of India	Jiaganj	11243442259	SBIN0001870
	TOTAL	614,624.00				
(Rupees six lakh fourteen thousand six hundred twenty four only)						

(Petrus Anuranjan Soreng)

Finance Officer
SUDA

(Goutam Hore)

Finance Officer
SUDA

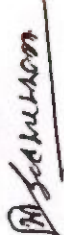

WEST BENGAL STATE URBAN LIVELIHOOD MISSION

(Under Municipal Affairs Department, Government of West Bengal)

"ইলগাস ভবন", এইচ-সি ব্লক, সেক্টর-৩, বিধাননগর, কলকাতা ৭০০ ১০৬, পশ্চিমবঙ্গ।

"ILGUS BHAVAN", H-C Block, Sector-III, Bidhannagar, Kolkata 700 106, West Bengal.

SUDA-118/16/7892

Date: -11/12/2019

Memorandum

Release of fund to Habra Municipality for construction of Boundary wall of shelter for Urban Homeless under DAY-NULM

Funds shown herein are being released electronically in favour of Habra Municipality for construction of 'Boundary wall' under shelter for urban homeless of DAY-NULM. This release is the 1st installment.

Utilisation Certificate of the funds received from SUDA may please be sent to this office in GFR-12C and uploaded at sudawb.org → e-services positively within 90 days.

SL NO.	Name of ULB	Amount (Rs. In Lakh)		Total
		Central Share	State Share	
I.	Habra Municipality	1.72	1.14	2.86

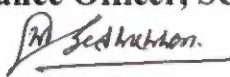
Finance Officer, SUDA

দুরভাষ: ২৩৫৮ ৬৪০৩/৬৪২১/৫৭৬৭, ফ্যাক্স : ২৩৫৮৫৮০০

Tel: 2358-6403/6421/5767, Fax: 2358-5800, E-Mail: wbsulm@gmail.com

SUDA-118/16/7892/1(2)

11.12.2019

Copy for information to:

The Chairman/Executive Officer of Habra Municipality.

He/she is requested to verify the respective Account of NULM of ULBs that the sanctioned amount has duly been credited. For any discrepancy, he/she is requested to report the same immediately to SUDA.

2. SMM, S&SI, NULM.

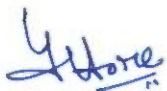
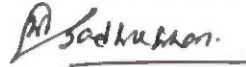
Finance Officer, SUDA

Note No. #1

Sub: Release of fund (final installment) for construction of Boundary Wall of SUH-Habra under the scheme shelter for Urban Homeless (SUH) under DAY-NULM at Habra Municipality

It may be mentioned that a proposal for **construction of Boundary Wall of SUH** of SUH at Habra Municipality was sanctioned as per post facto approval of Project Sanction Committee with a sanctioned cost of **Rs. 573406.00** in favour of Habra Municipality On 29.08.2019 (copy placed in the C.P. side for your kind perusal). As per administrative approval & financial sanction, 50% fund (1 st installment) has been released after issuance of work order for the aforesaid work.

Now the ULB has completed the construction of Boundary Wall of SUH. A completion certificate with a completion value has been submitted by the ULB which is signed by Executive Engineer, MED, North 24 PS Division. Also concerned ULB submitted the UC of 1 st installment for construction of Boundary Wall of SUH in GFR-12C format duly signed by the Chairperson, BOA, Habra Municipality, FO, Habra Municipality and Executive Engineer, MED, North 24 PS Division. A fund requisition for the remaining fund for the same is submitted by the concerned ULB.

Now fund amounting of **Rs. 2.13 Lakh (Central 1.27 Lakh State:0.86 Lakh)** may be released in favour of Habra Municipality as 2 nd installment for the settlement of the bills for the aforementioned purpose.

Submitted for your kind perusal.

14/09/2020 1:58 PM

SOUMEN DE
(SMM-WBSULM(NULM)(SUDA))

Note No. #2

A fund amounting to **Rs. 2.13 Lakh (Central 1.27 Lakh State:0.86 Lakh)** may be released in favour of Habra Municipality as 2 nd installment and for the settlement of the bills for the construction of Boundary Wall of SUHs. All previous UCs and work completion certificate given.

17/09/2020 10:50 PM

SHAON SEN
(AD DIR(SUDA))

Note No. #3

As proposed.

18/09/2020 11:37 AM

SANTANU MUKHERJEE
(DIR(SUDA))

Note No. #4

FO may kindly release fund

18/09/2020 1:06 PM

SHAON SEN
(AD DIR(SUDA))

Note No. #5

Please process.

18/09/2020 3:06 PM

GOUTAM HORE
(FO(ACCT)(SUDA))

সুডা



রাজ্য নগর উন্নয়ন সংস্থা

SUDA

STATE URBAN DEVELOPMENT AGENCY

“ইলগাস ভবন”, এইচ-সি ব্লক, সেক্টর-৩, বিধাননগর, কলকাতা-৭০০ ১০৬, পশ্চিমবঙ্গ

“ILGUS BHAVAN”, H-C Block, Sector - III, Bidhannagar, Kolkata - 700 106, West Bengal

SUDA-118/16/7798
ক্রমিক নং

05.12.2019
তারিখ

From : Director, SUDA

To : The Manager,
State Bank of India,
Salt Lake City, Kolkata - 700 091.

**Sub: Electronic Transfer of Fund debiting this office
Current Account No. 37715094723**

Shelter for Urban Homeless under NULM

Sir,

You are requested to kindly arrange for electronic transfer of funds as per details given below debiting the amounts from this office Current Account No.37715094723 lying with your branch in respect of **Construction of Boundary wall of SUH under DAY-NULM.**

Sl. No.	Name of Payee	Amount (In Rs.)	Payees' Bank Details
01	Habra Municipality	2,86,703.00	State Bank Of India, Banipur Branch, A/C No. 35156397259, IFS Code. SBIN0016644
TOTAL		2,86,703.00	
(Rupees Two lakh eighty six thousand seven hundred three only)			

(Petrus Anuranjan Soreng)
Finance Officer
SUDA

(Debarati Dutta Gupta)
Director
SUDA



দূরভাষ : ২৩৫৮ ৬৪০৩ / ৫৭৬৭, ফ্যাক্স : ২৩৫৮ ৫৮০০

Tel : 2358 6403/5767, Fax : 2358 5800, E-mail : wbsudadir@gmail.com

Account Section : 2358 6408



HABRA MUNICIPALITY

(ESTD.-1979)

POURA BHAWAN

PROMODE DASGUPTA SARANI, P.O. HIJALPUR, NORTH 24 PARGANAS, PIN - 743271
email : habramunicipality@yahoo.com



Ref. No. HM/3038/NULM/19...

Date 26-11-2019.....

To
The Director SUDA & Mission Director, WBSULM
ILGUS Bhawan, HC-Block,
Sector III, Bidhannagar,
Kolkata 700106

**Sub: Requisition of fund for Construction of Boundary Wall at "Bibekananda Bhawan"
(SUH) under DAY-NULM at Habra Municipality**

Ref: SUDA-118/16/6181 dated: 29/08/2019

Sir/Madam,

This is to inform you that Habra Municipality has issued a work order for Construction of Boundary Wall at Bibekananda Bhawan (SUH) at Ward no. 22 of Habra Municipality. As per letter provided by you vide letter no. SUDA-118/16/6181 dated 29/08/2019 we are placing a requisition for 50% fund for the same.

Thanking You

Encl: Work Order Copy

Yours faithfully

[Signature]
Executive Officer
Habra Municipality

Executive Officer
HABRA MUNICIPALITY

HABRA MUNICIPALITY

(ESTD.-1979)

POURA BHAWAN

PROMODE DASGUPTA SARANI, P.O. HIJALPUR, NORTH 24 PARGANAS, PIN - 743271
email : habramunicipality@yahoo.com



Ref. No. HM/2182/1/P.W.D/19

Date 14-11-2019

To
Goutam Das
Ashutosh Colony
Habra, North 24 Parganas

Sub.: Letter of Acceptance cum Work Order for "Construction of Boundary wall at Vivekananda Bhawan at Ward No-22 within Habra Municipality".

Ref: WBMAD/HM/PWD/NIT-e-459/2019-20.
Tender Id:- 2019_MAD_244730_1

With reference to the above mentioned subject and as per approval of the Evaluation Committee of this Municipality has accepted your offered rate.

Estimated amount	Offered Rate (inclusive of all taxes & other incidental charges)	Percentage above/below w.r.t. estimated amount	Time of Completion
Rs 556865.19	Rs 555584.40	0.23 % (below)	90 (Ninety) Days from the date of issue of this letter

- 1) You are requested to purchase 2 (two) sets of formal tender paper for the work from this office on payment of Rs.1000/- (Rupees One Thousand only) each and submit the same duly filled and signed from your end within 7 (seven) working days from the issue of this letter failing on which this order will be treated as cancelled.
- 2) **Inspection:-** 1st party inspection by the SAE of this Municipality at your works.
- 3) **Security Deposit:-** Security Deposit will be 10% of Work value(inclusive of 2% of EMD). Total 30% of S.D. Shall be refunded to the contractor on expiry of 2(two) years from the actual date of completion of the work and the balance 70% of the security deposit shall be refunded to the contractor on expiry of 3 (three) years from the actual date of completions of the work.

Thanking you,

sdf
Administrator
Habra Municipality

(Memo No. HM/2182/1/P.W.D/19

Dated 14-11-2019)

Copy forwarded for information to:-

1. Executive Officer, Habra Municipality
2. Finance Officer, Habra Municipality
3. S.A.E, Habra Municipality.
4. Office, Habra Municipality

Sankar Sarkar
Administrator
Habra Municipality
Administrator
Habra Municipality

STATE URBAN DEVELOPMENT AGENCY

“ইলগাস ভবন”, এইচ-সি ব্লক, সেক্টর-৩, বিধাননগর, কলকাতা-৭০০ ১০৬, পশ্চিমবঙ্গ
“ILGUS BHAVAN”, H-C Block, Sector - III, Bidhannagar, Kolkata - 700 106, West Bengal

ক্রমিক নং

SUDA-118/16/৫১৪১

তারিখ

29.08.2019

From : Shri Joly Chaudhuri WBCS (Exe.),
Jt. Secretary, UD & MA Department &
Addl. Mission Director, WBSULM

To : Administrator,
Habra Municipality

Sub : Administrative approval & financial sanction for ‘Construction of boundary wall for SUH at Habra’

Sir,

Administrative approval & financial sanction is hereby accorded for the scheme ‘Construction of boundary wall for SUH at Habra’ at an estimated cost of ₹ 573406.00 (₹ Five lakh seventy three thousand four hundred and six) only at Habra Municipality.

Fund to be released in 2 (two) equal instalments only after receipt of requisition from Habra Municipality. 50% of the fund to be released after issuance of work order. Rest 50% to be released after completion of the scheme and submission of a physical completion report by the implementing agency. The work will be tendered by Habra Municipality and executed under technical supervision of MED. Work to be executed strictly in accordance with the estimate vetted by the MED. Onsite deviation during execution required if any is to be carried out with prior approval from this office. The sanctioned amount is not to be utilised for any other purposes other than the scheme for which it has been sanctioned.

This issues with the approval of the Principal Secretary, UD & MA Department, Govt. of West Bengal.

Yours faithfully,

Chandhu
29.08.19

Jt. Secretary, UD & MA Dept.

&

Addl. Mission Director, WBSULM

SUDA-118/16/ ৫১৪১/১(৬)

29.08.2019

Copy forwarded for information to :

- (1) Secretary, MED
- (2) Chief Engineer, MED
- (3) Executive Officer, Habra Municipality
- (4) Superintending Engineer, MED (Concerned Circle)
- (5) Executive Engineer, North 24 Paraganas Division
- (6) CMMU, Habra Municipality

Chandhu
28.08.19

Jt. Secretary, UD & MA Dept.

&

Addl. Mission Director, WBSULM

দূরভাষ : ২৩৫৮ ৬৪০৩ / ৫৭৬৭, ফ্যাক্স : ২৩৫৮ ৫৮০০

Tel : 2358 6403/5767, Fax : 2358 5800, E-mail : wbsudadir@gmail.com

Account Section : 2358 6408

Phone No. : 03216 270572
Fax No. : 03216 237031



HABRA MUNICIPALITY

(ESTD.-1979)

POURA BHAWAN

PROMODE DASGUPTA SARANI, P.O. HIJALPUKURIA, NORTH 24 PARGANAS, PIN - 743271
email : habramunicipality@yahoo.com

Ref. No. ...HM/1279/NULM/19

Date ...28/08/2019.....

To
Jt. Secretary UD & MA Department,
& Addl. Mission Director, WBSULM
ILGUS Bhawan, HC-Block,
Sector III, Bidhannagar,
Kolkata 700106

Sub: Submission of vetted estimate of Boundary Wall at "Bibekananda Bhawan"(Shelter for Urban Homeless) of ward no. 22 within Habra Municipality under DAY-NULM

Ref: Your office memo no: SUDA-23/2014(MPR)/4468(35)

Sir,

In reference to the above letter no. I am herewith submitting the estimate of Boundary Wall for "Bibekananda Bhawan" (Shelter for Urban Homeless) under Habra Municipality duly vetted amounting to Rs. 5,73,406.00 (Rupees Five Lakh Seventy Three Thousand Four Hundred and Six) only for your necessary approval.

Thanking You

Encl: As Stated

Yours Faithfully

Administrator
Habra Municipality
Administrator
HABRA MUNICIPALITY



Government of West Bengal
Office of the Executive Engineer, North 24-Parganas Division,
Municipal Engineering Directorate
7, K.B. Bose Rd. (2nd floor) Barasat, North 24-Pgs
Kolkata-700 124
Phone No.:- (033) 2584-4288
Email :- north24pgsdivisionmed@gmail.com

No. : MED/PRG-1/ 490 /1N-08/16

Date:- 20.08.2019

To
The Chairman
Habra Municipality
North 24-Parganas

Sub : Vetting of estimate for Boundary Wall at "Bibekananda Bhawan"
(Shelter for Urban Homeless) of ward no 22 within Habra Municipality
under NULM.

Ref: Your office memo no. HM/1143/NULM/19 dt.08.08.2019

Sir,

Enclosed please find herewith the estimate in duplicate for above noted work under NULM of your municipality amounting to ₹ 5,73,406.00 (Rupees Five Lakh Seventy Three Thousand Four Hundred Six) only including 12 % G.S.T., 1% Labour Welfare CESS & 3% contingency duly vetted from this end for favour of your kind information and further necessary action from your end.

Thanking you,

Encl. : As stated

Yours faithfully,

sd/-

Executive Engineer
North 24-Pgs. Division, M.E.Dte.

No. : MED/PRG-1/ 490(1) /1N-08/16

Date:- 20.08.2019

Copy forwarded for information to :

- 1) The Jt. Secretary, UD & MA Department, & Adtl. Mission Director, WBSULM
- 2) The Chief Engineer, M.E.Dte. Bikash Bhavan (1st floor), Salt Lake City, Kolkata- 700 091
- 3) The Superintending Engineer, East Circle, M.E.Dte., AB - 30/1, Prafullya Kanan (West), Krishnapur, Baguiati, Kolkata - 700101

Executive Engineer
North 24-Pgs. Division, M.E.Dte.
Municipal Engineering Directorate
Deptt. of U.D. & M.A.
Government of West Bengal

ESTIMATE FOR PROPOSED CONSTRUCTION OF BOUNDARY WALL AT BIBEKANANDA BHAWAN OF WARD NO.22, UNDER HABRA MUNICIPALITY, DIST.:- NORTH 24 PARGANAS, RATES ARE FOLLOWED AS PER PWD (WB) SCHEDULED OF RATES FOR BUILDING WORKS W.E.F.

01.11.2017 (length of boundary wall is 27 m + 20 m = 47 m)

SL. NO.	DESCRIPTION OF WORK	QNTY.	UNIT	RATE	AMOUNT (IN RS.)
1	Earth work in excavation of foundation trenches or drains, in all sorts of soil (including mixed soil but excluding laterite or sandstone) including removing, spreading or stacking the spoils within a lead of 75 m. as directed. The item includes necessary trimming the sides of trenches, levelling, dressing and ramming the bottom, bailing out water as required complete. (Page No.-1, Item No.-2 (a)).	9.113	% Cum	11927.00	1086.91
2	Single Brick Flat Soling of picked jhama bricks including ramming and dressing bed to proper level and filling joints with local sand. (V.P.No.-14, It. No -1)	20.750	Sq.M.	361.00 358.00	7490.75 7428.50
3	Earth work in filling in foundation trenches or plinth with good earth, in layers not exceeding 150 mm. including watering and ramming etc. layer by layer complete. (Payment to be made on the basis of measurement of finished quantity of work). (a) With earth obtained from excavation of foundation. (Page No.- 1, Item No.- 3)	3.038	% Cum	7754.00	235.57
4	Cement concrete with graded stone ballast (40 mm size excluding shuttering) In ground floor (A). [Pakur Variety]. (a) (1:3:6) proportion.	3.947	Cu.M	4761.00 5376.00	18614.05 21219.07
5	Hire and labour charges for shuttering with cantering and necessary staging up to 4 m using approved stout props and thick hard wood planks of approved thickness with required bracing for concrete slabs, beams and columns, lintels curved or straight including fitting, fixing and striking out after completion of works (up to roof of ground floor) (When the height of a particular floor is more than 4 m the equivalent floor height shall be taken as 4 m and extra for works beyond the initial 4 m ht. shall be allowed under 12 (e) for every 4 m or part thereof) (a). 25 mm to 30 mm thick wooden shuttering as per decision & direction of Engineer-In Charge. (Page No.- 42, Item No.- 36).	81.400	Sq.m	209.00	17012.60
6	Ordinary Cement concrete (mix 1:1.5:3) with graded stone chips (20 mm nominal size) excluding shuttering and reinforcement if any, in ground floor as per relevant IS codes. (i). Pakur Variety.(Annalysed rate).	9.964	Cu.M	6184.13	61618.67
7	Reinforcement for reinforced concrete work in all sorts of structures including distribution bars, stirrups, binders etc initial straightening and removal of loose rust (if necessary), cutting to requisite length, hooking and bending to correct shape, placing in proper position and binding with 16 gauge black annealed wire at every intersection, complete as per drawing and direction. (a) For works in foundation, basement and up to roof of ground floor/up to 4 m (i). Tor steel/Mild Steel. (Annalysed rate)	1.284	M.T.	70362.85	90345.90
8	Brick work with 1st class bricks in cement mortar (1:6) (a). In foundation and plinth.(Page No.- 15, Item No.- 8).	7.540	Cu.M.	5413.00 5306.00	40814.02 40007.24
9	(a) M.S.or W.I. Ornamental grill of approved design joints continuously welded with M.S, W.I. Flats and bars of windows, railing etc. fitted and fixed with necessary screws and lugs in ground floor. (Add extra @ 1% for each addl. floor upto 4th floor and @ 1.25% for each addl. floor above 4th floor) (i) Grill weighing above 10 Kg./sq.mtr and up to 16 Kg./sq. mtr. Qntl 8247	21.330	Qntl.	7238.00 7238.00	210211.04 154386.54

10	(a). M.S. gate of jali type as per approved design made of strong M.S. frame work ,intermediate stiffeners and round/ square bars ,M.S. sheet (not less than 14 gauge) gussets,cleats etc. including necessary riveting,bolting,welding,locking and hanging arrangements,fitting and fixing complete as per direction of the Engineer - in - Charge.	0.702	Qntl.	10090.00	7083.18
11	Plaster (to wall, floor, ceiling etc.) with sand and cement mortar including rounding off or chamfering corners as directed and raking out joints including throating, nosing and drip course, scaffolding/staging where necessary (Ground floor).[Excluding cost of chipping over concrete surface] With 1:4 cement mortar (b) 15 mm thick plaster (Page No.- 189, Item No.-1).	101.506	Sq.M.	167.00	16951.50
12	Neat cement punning about 1.5mm thick in wall,dado>window sill,floor etc. NOTE:Cement 0.152 cu.m per100 sq.m.Sq.M 38 (Page No.- 192, Item No.- 15).	101.506	Sq.M.	151.00	15327.41
13	Priming one coat on timber or plastered surface with synthetic oil bound primer of approved quality including smoothening surfaces by sand papering etc. (Page No -162, Item No.-7(a)).(vide Item no.11)	28.425	Sq. M.	38.00	1080.15
14	(b) Priming one coat on steel or other metal surface with synthetic oil bound primer of approved quality including smoothening surfaces by sand papering etc.	101.506	Sq.M.	38.00	3857.23
15	Applying decorative cement based paint of approved quality after preparing the surface including scraping the same thoroughly (plastered or concrete surface) as per manufacturer's specification. Two coats. Page No.-197, Item No.-15.(vide Item no.11)	120.185	Sq.M.	29.00	3485.37
16	(A). Painting with best quality synthetic enamel paint of approved make and brand including smoothening surface by sand papering etc. including using of approved putty etc. on the surface if necessary.(vide Item no.14)	101.506	Sq.M.	49.00	4973.79
		120.185	Sq.M.	79.00	9494.62

checked
Prabha
19/08/19
Junior Engineer (Civil)
 North 24 Parganas Division
 Municipal Engineering Directorate
 Deptt. of U.D. & M.A.
 Government of West Bengal

$= ₹ 492278 = 25$
 $= ₹ 59072 = 39$
 $= ₹ 551351 = 64$
 $= ₹ 5513 = 52$
 $= ₹ 556865 = 16$
 $= ₹ 16540 = 55$
 $= ₹ 573405 = 71$
Say = ₹ 5,73,408 = 00

(Rupees Five Lakhs Seventy three thousand Two Hundred and Sixty Seven Only),
 May be Veted

Rs. 438642.75
 Add, GST@ 12 @ % Rs. 52637.13
 Rs. 491279.88
 Add, Labour Welfare Cess @ 1 % Rs. 6248.46
 Rs. 497528.34
 Add, Contingency @ 3 % Rs. 14738.40
 Rs. 512266.74
 Rs. 527000

VETTED
Prabha
Executive Engineer
 North 24- Parganas Division
 Municipal Engineering Directorate
 Deptt. of U.D. & M.A.
 Government of West Bengal

Prabha
Sub-Assistant Engineer
HABRA MUNICIPALITY
 Add. Engineer
 North 24- Parganas Division
 Municipal Engineering Directorate
 Deptt. of Municipal Affairs
 Government of West Bengal

Prabha
Administrator
HABRA MUNICIPALITY

**CALCULATION OF PROPOSED CONSTRUCTION OF BOUNDARY WALL AT BIBEKANANDA BHAWAN OF
WARD NO.22, UNDER HABRA MUNICIPALITY, DIST.:- NORTH 24 PARGANAS,
RATES ARE FOLLOWED AS PER PWD (WB) SCHEDULED OF RATES FOR BUILDING WORKS
W.E.F. 01.11.2017**

Sl. No.	Description of work	Quantity	Unit
1	Earth work in excavation of foundation trenches or drains,..... and ramming the bottom, bailing out water as required complete. (Page No.- 1, Item No.- 2 (a)). (18 Nos. x 0.750 m x 0.750 m x 0.900 m)	9.113	Cu.m.
2	Single Brick Flat Soling of picked jhama bricks including ramming and dressing bed to proper level and filling joints with local sand. . V.P.No.- , It. No - . (18x0.750x0.750) [((20.00+27.00)-(18x0.250))x0.250]	10.125 10.625 20.750	Sq.m.
3	Earth work in filling in foundation trenches or plinth with good earth, in layers not exceeding 150 mm. including watering and ramming etc. layer by layer complete. (Payment to be made on the basis of measurement of finished quantity of work). (a). With earth obtained from excavation of foundation. Page No.- 1. Item No.- 3. (1/3 of earth work excavation qty.) (i.e., 9.113/3)	3.038	Cu.m.
4	V.P.No.25,It.No.10(I) : Cement concrete with graded stone ballast (40 mm size excluding shuttering) In ground floor (A) [Pakur Variety] (a) (1:3:6) proportion. (18x0.75x0.75x0.075) (((20.00+27.00)-(18x0.250))x0.075)	0.759 3.188 3.947	Cu.m.
5	Hire and labour charges for shuttering with cantering and necessary staging up to 4 m..... (a). 25 mm to 30 mm thick wooden shuttering as per decision & direction of Engineer-In-Charge. Page No.- 26, Item No.- 12 (a). Col. Base : (18x4x0.750x0.150) Col. Above Taper : (4x18x0.375) Col. Above G.L. : (4x18x0.250x2.050) Copping portion : (2x(20.00+27.00)x0.100)	8.100 27.000 36.900 9.400 81.400	Sq.m.
6	Ordinary Cement concrete (mix 1:1.5:3) with graded stone chips as per relevant IS codes. (i). Pakur Variety. (Annalysised rate) Col. Base : (18x0.750x0.750x0.150) Col. At taper portion : (18x((0.750x0.750)+(0.250x0.250))/2x0.225) Tie Beam : (20.00+27.00)x0.250x0.250 Col. : (18x0.250x0.250x2.725) Reinf. Of Copping : ((20.0+27.0)x4x0.395)	1.519 1.266 2.938 3.066 1.175 9.964	Cu.m.
7	Reinforcement for reinforced concrete work in all sorts of structures including distribution bars, stirrups, binders etc initialfoundation, basement and up to roof of ground floor/up to 4 m (i) Tor steel/Mild Steel. (Page No.- 27, Item No.- 15 (a)). ((9.964x7850)/100) kg , i.e. (78217.400/100=782.40 kg) (9.964x0.012x7850) kg. =938.609 kg. (i.e. 0.939 MT)	0.939	M.T.

Sub-Engineer
HABRA MUNICIPALITY

	<p>brick work with 1st class bricks in cement mortar (1:4). (a) In foundation and plinth (Page No.- 15, Item No.- 8). Length of Brick Work : $\{[(20.250+27.125)-(19 \times 0.25)] = 42.625 \text{ m}\}$. Brick Work : $(42.625 \times 0.250 \times 0.700)$ Brick Work Pillar : $(1 \times 0.250 \times 0.250 \times 1.300)$</p>	7.459 0.081 7.540	Cu.m.
9	<p>(a) M.S.or W.I. Ornamental grill of approved design joints continuously welded with M.S, W.I. Flats and bars of windows, railing etc. fitted and fixed with necessary screws and lugs in ground floor. (Add extra @ 1% for each addl. floor upto 4th floor and @ 1.25% for each addl. floor above 4th floor) (i) Grill weighing above 10 Kg./sq.mtr and up to 16 Kg./sq. mtr. Qntl 8247 Grillage Portion : $\{[(20.250+27.125)-(2 \times 0.450 \times 0.250)] = 46.225 \text{ mtr}\}$ Grillage Portion : $\{(46.225 \times 1.300)\} = (60.093 \times 35.50) \text{ kg}$</p>	2133.28 21.330	Kg Qntl.
10	<p>(a). M.S.gate of jali type as per approved design made of strong M.S. frame work ,intermediate stiffeners and round/ square bars ,M.S. sheet (not less than 14 gauge) gussets,cleats etc. including necessary riveting,bolting,welding,locking and hanging arrangements,fitting and fixing complete as per direction of the Engineer - in - Charge. Gate Portion : $\{(1.200 \times 1.300) \times 45\} \text{ Kg.}$</p>	70.20 0.702	Kg Qntl.
11	<p>Plaster (to wall, floor, ceiling etc.) with sand and cement mortar including rounding off..... With 1:4 cement mortar (b) 15 mm thick plaster. Page No.- 189, Item No.-1. Brick Work Portion (Side) : $\{(20.250+27.125) \times (2 \times 0.700)\}$ Brick Work Portion (Top) : (42.625×0.250) Column Portion : $(18 \times 4 \times 0.25 \times 1.300 + 18 \times 0.25 \times 0.25)$</p>	66.325 10.656 24.525 101.506	Sq.m.
12	<p>Neat cement punning about 1.5mm thick in wall,dado,window sill,floor etc. NOTE:Cement 0.152 cu.m per 100 sq.m.Sq.M 38 Page No.- 152, Item No.- 8 Brick Work Portion (Side) : $\{(20.250+27.125) \times (2 \times 0.300)\}$</p>	28.425 28.425	Sq.m.
13	<p>(a). Priming one coat on timber or plastered surface with synthetic oil bound primer of approved quality including smoothing surfaces by sand papering etc. Page No.-162, Item no.-7(a) (vide Item no. 11)</p>	101.506	Sq.m.
14	<p>(b) Priming one coat on steel or other metal surface with synthetic oil bound primer of approved quality including smoothing surfaces by sand papering etc. Grillage Portion : $(46.225 \times 1.300) \times 2$</p>	120.185	Sq.m.
15	<p>Applying decorative cement based paint of approved quality after preparing the surface including scraping the same thoroughly (plastered or concrete surface) as per manufacturer's specification. Two coats. Page No.-158, Item no.-16(iii) (vide Item no. 11)</p>	101.506	Sq.m.
16	<p>(A). Painting with best quality synthetic enamel paint of approved make and brand including smoothing surface by sand papering etc. including using of approved putty etc. on the surface if necessary. B). On steel or other metal surface. With super gloss -(hi - gloss).Two coats (With any shade except white). (vide Item no. 14)</p>	120.185	Sq.m.

Sub-Assistant Engineer
HABRA MUNICIPALITY

PROPOSED CONSTRUCTION OF BOUNDARY WALL AT THE PREMISES SHELTER UNDER THE SCHEME "SHELTER FOR URBAN HOMELESS(SUH) UNDER DAY-NULM

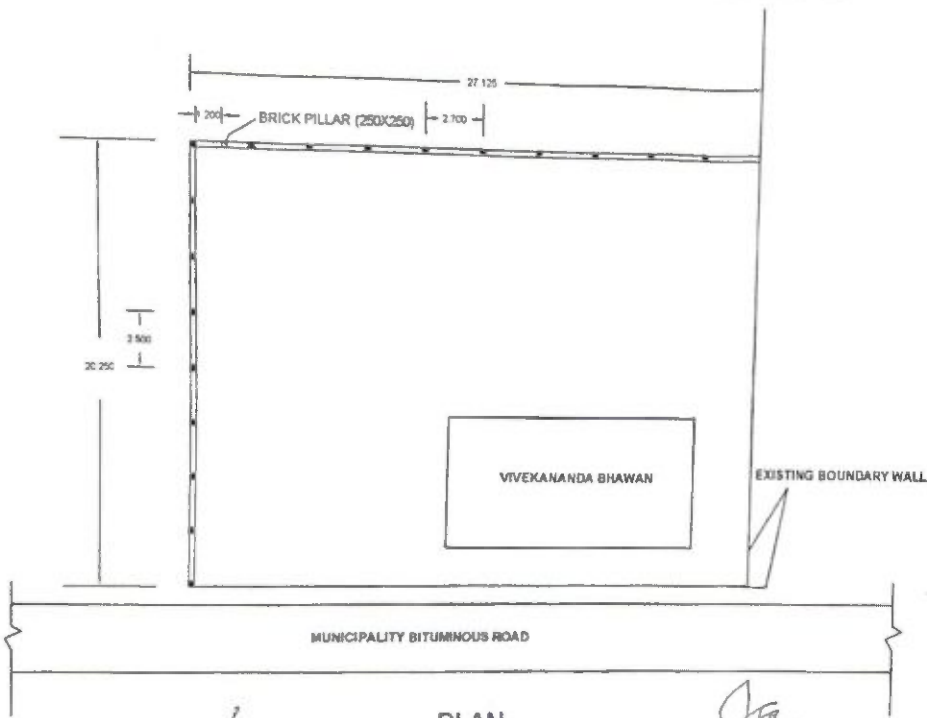

PLAN

Sub-Assistant Engineer
HABRA MUNICIPALITY

Administrator
HABRA MUNICIPALITY

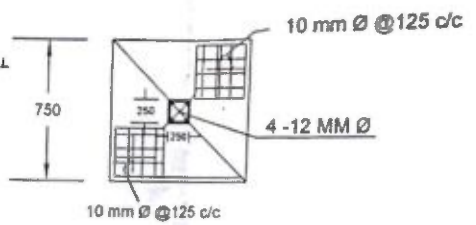
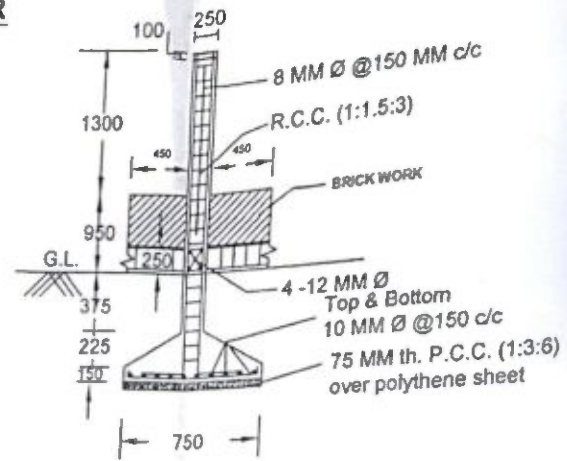

SECTION OF COLUMN

সুডা

NOTE SHEET

SUDA

Construction of 22 (twenty two) SUHs have been completed and of which 14 (fourteen) SUHs have been made functional. During visits to this facilities and based on the feedback received from the operating NGOs, it is absolutely essential to construct a boundary wall enclosing the entire perimeter of the land allocated for the construction of the SUHs. This is essential not just to ensure the safety and security of the inmates but also to enable the SUHs to raise a kitchen garden and / or a work shed for some economic activities. A model estimate for a meter of boundary wall has been prepared by MED along with a cross section of the boundary wall (placed on the cp side) put at Rs.10,522 (Rs. ten thousand five hundred & twenty two only). The following decision points may kindly be accorded.

1. An in-principle approval for construction of boundary wall may be given at all SUHs which are completed / ongoing.
2. Infrastructure of 22 (twenty two) SUHs have been completed and 20 (twenty) SUHs are in progress. Therefore the boundary wall would have to constructed at 42 (forty two) sites.
3. The concerned ULBs may be required to prepare a vetted estimate based on the perimeter of the allotted land and submit the same to SUDA for according administrative approval and financial sanction.
4. The proposal so received and approved may be placed at the Project Sanction Committee for post facto approval.
5. The cost for the boundary wall may be charged out of the NULM fund.

Shankar
24/06/19
AMD

Director, SUDA

Proposal above may kindly be approved.

sd/ 24/6/19

~~Pr. Secretary
D & MA Deptt.~~

FA

U.O. No. SUDA...309.....

Director, SUDA

Dated...24.06.19.....

File No. SUDA-317/2016

~~DFA (PS)~~

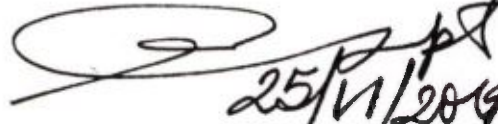
25/11/2019

26/06/19

File No. SUDA-317/2016

File Name: Shelter for Urban Homeless under NULM for Rajpur Sonarpur Municipality

Notes prepages

The rate analysis for boundary wall appears to be in order as per PWD SOR 2017 read with the corrigenda issued from time to time.

The proposal at nsp 5 may be approved.

Prasanta Sengupta 27/06/19

(Prasanta Sengupta)
Dy Financial Advisor
UD & MA Department

Kishore Sengupta 27/06/19

(Kishore Sengupta)
Financial Advisor & E.O. S. S
UD & MA Department

~~Principal Secretary,
U.D. & M.A. Department~~

Director, SUDA

~~*ACD*~~

S. De. SMM

Drop-please

[Signature]
27/06/2019

28/6

[Signature]
27/06/19



9/1

Government of West Bengal
Office of the Executive Engineer, North 24-Parganas Division,
Municipal Engineering Directorate
7, K.B. Bose Rd. (2nd floor) Barasat, North 24-Pgs
Kolkata-700 124
Phone No.:- (033) 2584-4288
Email :- north24pgsdivisionmed@gmail.com

No. : MED/PRG-1/ 458 /1N-08/16

Date:- 09.08.2019

To
The Chief Engineer,
M. E. Dte.
Bikash Bhavan(1st floor)
Salt Lake City
Kolkata – 700 091

Sub : Submission of Utilisation Certificate for construction of 50 bedded, 4 storied Shelter for Urban Homeless under DAY-NULM for the town Habra under the jurisdiction of North 24-Parganas Division.

Ref. : Chairman's office memo no. HM/1138/NULM/19 dt.08.08.2019

Sir,

Enclosed please find herewith the Utilisation Certificate in duplicate for construction of 50 bedded, 4 storied Shelter for Urban Homeless under Deendayal Antyodaya Yojana – National Urban Livelihoods Mission (DAY-NULM) at ward no. 22 as submitted by the Chairman, Habra Municipality and duly checked by this end for favour of your kind information and taking necessary action.

Thanking you,
Enclo. : As stated

Yours faithfully,



Executive Engineer
North 24-Parganas Division
Municipal Engineering Directorate
North 24-Pgs. Division, M. E. Dte. of U.D. & M.A.
Government of West Bengal

No. : MED/PRG-1/ 458(3/3) /1N-08/16

Date:- 09.08.2019

Copy forwarded for information to :

- 1) The Chairman, Habra Municipality– along with a copy of U.C.
- 2) The Director, SUDA, Ilgus Bhavan, Salt Lake City, Kolkata – along with 2 (Two) copies of U.C.
- 3) The Superintending Engineer, East Circle, M.E.Dte., AB - 30/1, Prafullya Kanan (West), Krishnapur, Baguiati, Kolkata – 700101



Executive Engineer
North 24-Parganas Division
Municipal Engineering Directorate
North 24-Pgs. Division, M. E. Dte.
Deptt. of U.D. & M.A.
Government of West Bengal



Government of West Bengal

Office of the Executive Engineer, North 24-Parganas Division,

Municipal Engineering Directorate

7, K.R. Bose Rd. (2nd floor) Barasat, North 24-Pgs

Kolkata-700 124

Phone No.:- (033) 2584-4288

Email :- north24pgsdivisionmek@gmail.com

No. : MED/PRG-1/ 458 g /1N-08/16

Date:- 09.08.2019

To
The Chief Engineer,
M. E. Die,
Bikash Bhavan(1st floor)
Salt Lake City
Kolkata - 700 091

Sub : Submission of Utilisation Certificate for construction of 50 bedded, 4 storied Shelter for Urban Homeless under DAY-NULM for the town Habra under the jurisdiction of North 24-Parganas Division.

Ref. : Chairman's office memo no. HNM/1138/NULM/19 dt.08.08.2019

Sir,
Enclosed please find herewith the Utilisation Certificate in duplicate for construction of 50 bedded, 4 storied Shelter for Urban Homeless under Deendayal Aahyodaya Yojana - National Urban Livelihoods Mission (DAY-NULM) at ward no. 22 as submitted by the Chairman, Habra Municipality and duly checked by this end for favour of your kind information and taking necessary action.

Thanking you,

Encls. : As stated

Yours faithfully,

No. : MED/PRG-1/ 458(g/p) /1N-08/16

Date:- 09.08.2019

Copy forwarded for information to :

- 1) The Chairman, Habra Municipality - along with a copy of U.C.
- 2) The Director, SUDA, Ilgus Bhavan, Salt Lake City, Kolkata - along with 2 (Two) copies of U.C.
- 3) The Superintending Engineer, East Circle, M.E. Die., AB - 30/1, Prafulliya Kanon (West), Krishnapur, Baguani, Kolkata - 700101

Executive Engineer

North 24-Parganas Division
Municipal Engineering Directorate
Salt Lake City, Kolkata - 700 091
Government of West Bengal

Executive Engineer

North 24-Pgs Division
Municipal Engineering Directorate
Salt Lake City, Kolkata - 700 091
Government of West Bengal

GFR 12-C
[[See Rule 239]]

UTILIZATION CERTIFICATE
(Where expenditure incurred by Govt. bodies only)

For Construction of SUH for the F.Y. 18-19

Sl. No.	Letter No. and date	Amounts Rs.	Certified that out of Rs. 97,80,000 (Rupees ninety seven lakh eighty thousand only) of grant sanctioned during the year 2016 -17 & 2017-18 in favour of Habra Municipality North 24 Parganas Letter No. given in the margin and NIL on account of unspent balance of previous year, a sum of Rs.95,62,778 (Rupees ninety five lakh sixty two thousand seven hundred seventy eight) has been utilized for the purpose of Construction of SUH for which it was sanctioned and that the balance of Rs. 2,17,222 (Rupees two lakh seventeen thousand two hundred twenty two only) remaining unutilized at the end of the year will be adjusted/utilized in next year.
1.	SUDA-23/2014(Pt.)/1048 dated: 19/07/2016	48,90,000	
2.	SUDA-23/2014(pt - II)/1425 dated: 04/12/2018	48,90,000	
Total		97,80,000	

2. Certified that I have satisfied myself that the conditions on which the grants-in-aid was sanctioned have been duly fulfilled and that I have exercised the following checks to see that the money was actually utilized for the propose for which it was sanctioned.

Kinds of checks exercised:

Examination of 1. Vouchers, 2. Cash Book, 3. Ledger, 4. Statement of Expenditure & 5. Statement of Fund Position

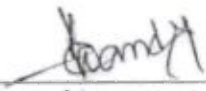
Signature of Accountant (DAY-NULM),
Habra Municipality

Signature of Administrator
Habra Municipality
HABRA MUNICIPALITY

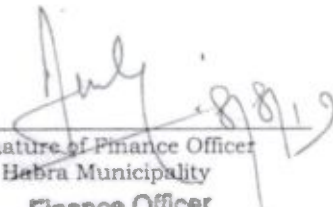
Signature of Finance Officer
Habra Municipality
Finance Officer
Habra Municipality

CS

Executive Engineer
Signature of Executive Engineer
M.E. Dte., North 24 Parganas Division, Barasat
Municipal Engineering Directorate
Deptt. of U.D. & M.A.
Government of West Bengal]

UTILIZATION CERTIFICATE
(Where expenditure incurred by Govt. bodies only)

For Construction of SUH for the F.Y. 18-19

Sl. No.	Letter No. and date	Amounts Rs.	Certified that out of Rs. 97,80,000 (Rupees ninety seven lakh eighty thousand only) of grant sanctioned during the year 2016 -17 & 2017-18 in favour of Habra Municipality North 24 Parganas Letter No. given in the margin and NIL on account of unspent balance of previous year, a sum of Rs.95,62,778 (Rupees ninety five lakh sixty two thousand seven hundred seventy eight) has been utilized for the purpose of Construction of SUH for which it was sanctioned and that the balance of Rs. 2,17,222 (Rupees two lakh seventeen thousand two hundred twenty two only) remaining unutilized at the end of the year will be adjusted/utilized in next year.
1.	SUDA-23/2014(Pl./1048 dated: 19/07/2016	48,90,000	
2.	SUDA-23/2014(pt - II)/1425 dated: 04/12/2018	48,90,000	
Total		97,80,000	

2. Certified that I have satisfied myself that the conditions on which the grants-in-aid was sanctioned have been duly fulfilled and that I have exercised the following checks to see that the money was actually utilized for the propose for which it was sanctioned.

Kinds of checks exercised:

Examination of 1. Vouchers, 2. Cash Book, 3. Ledger, 4. Statement of Expenditure & 5. Statement of Fund Position

Signature of Accountant (DAY-NULM),
Habra Municipality

Signature of Finance Officer
Habra Municipality
Finance Officer
Habra Municipality
c/s

Signature of Administrator
Habra Municipality
HABRA MUNICIPALITY

Signature of Executive Engineer
M.E. Dc., North 24 Parganas Division, Barasat
Municipal Engineering Office, Barasat
Deptt. of U.D. & M.A.
Government of West Bengal

সুডা

রাজ্য নগর উন্নয়ন সংস্থা

SUDA

STATE URBAN DEVELOPMENT AGENCY

“ইলগাস ভবন”, এইচ-সি ব্লক, সেক্টর-৩, বিধাননগর, কলকাতা-৭০০ ১০৬, পশ্চিমবঙ্গ

“ILGUS BHAVAN”, H-C Block, Sector - III, Bidhannagar, Kolkata - 700 106, West Bengal

ক্রমিক নং SUDA-118/16/১৯৭১

31.07.2019

তারিখ

From : Director, SUDA

To : The Manager,
State Bank of India,
Salt Lake City, Kolkata - 700 091.Sub: Electronic Transfer of Fund debiting this office
Current Account No. 37715094723

Shelter for Urban Homeless under NULM

Sir,

You are requested to kindly arrange for electronic transfer of funds as per details given below debiting the amounts from this office Current Account No. 37715094723 lying with your branch in respect of O&M cost of shelter for Urban Homeless under DAY-NULM.

Sl. No.	Name of Payee	Amount (In Rs.)	Payees' Bank Details
01	Habra Municipality	1,17,125.00	State Bank Of India, Banipur Branch, A/C No. 35156397259, IFS Code. SBIN0016644
TOTAL		1,17,125.00	
(Rupees one lakh seventeen thousand one hundred twenty five only)			

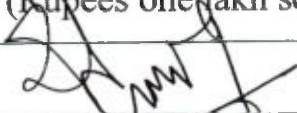
(Petrus Anuranjan Soreng)
Finance Officer
SUDA



০৭/০৭/১৯

(Debarati Dutta Gupta)
Director
SUDA

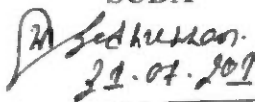
21.07.2019

দূরভাষ : ২৩৫৮ ৬৪০৩ / ৫৭৬৭, ফ্যাক্স : ২৩৫৮ ৫৮০০

Tel : 2358 6403/5767, Fax : 2358 5800, E-mail : wbsudadir@gmail.com

Account Section : 2358 6408



o/c

Phone No. : 03216 270572
Fax No. : 03216 237031

HABRA MUNICIPALITY

(ESTD.-1979)

POURA BHAWAN

PROMODE DASGUPTA SARANI, P.O. HIJALPUKURIA, NORTH 24 PARGANAS, PIN - 743271
email : habramunicipality@yahoo.com

Ref. No. ...H.M./0383/NULM/19

Date10./07/2019.....

To
The Director SUDA & Mission Director, WBSULM
ILGUS Bhawan, HC-Block,
Sector III, Bidhannagar,
Kolkata 700106

Requisition of fund for Operation & Maintenance of "Bibekananda Bhawan" - SUH under DAY-NULM

Madam,

With reference to the above this is to inform you that Habra Municipality has inaugurated 50 bedded shelter for urban homeless - "Bibekananda Bhawan" and it is functional from 28th February 2018. There are 12 beneficiaries presently residing at Bibekananda Bhawan. The detailed requisition for O&M cost for the month of June, July & August 2019 is mentioned below:

Sl No	Item	Quantity	Unit	Rate	Amount
				Rs.	Rs.
1.	Annual Maintenance Cost of Shelter				
i.	Electricity Charges	3	months	5000.00	15,000.00
ii.	Maintenance of plumbing & electrical work	3	months	500.00	1500.00
2.	Annual Servicing Cost				
i.	Sweeping Charges	3	months	3000.00	9,000.00
ii.	Replenishment of bedding	10%	Of capital cost for 3 months		3,124.99
3.	Cost of providing free food for 10% of inmates who are old/infirmand cannot pay (15*90*10%)	(15*90*10%)	days	100.00	13,500.00
4.	Staff Salary				
i.	Manager (full time)	3	months	10000.00	30,000.00
ii.	Caregivers: 3 nos. for 3 shifts of 8 hours	3 X 3=9	months	5000.00	45,000.00
Total					1,17,124.99

Therefore I request you to kindly release the fund required for operation & maintenance of SUH for smooth functioning of the same.

Thanking You

Yours faithfully

Administrator
Habra Municipality
Administrator
HABRA MUNICIPALITY



HABRA MUNICIPALITY

(ESTD.-1979)

POURA BHAWAN

PROMODE DASGUPTA SARANI, P.O. HIJALPUKURIA, NORTH 24 PARGANAS, PIN - 743271
email : habramunicipality@yahoo.com

Ref. No. HM/0388/NULM/19

Date10/03/2019.....

To
The Director SUDA & Mission Director WBSULM
ILGUS Bhawan, HC-Block,
Sector-III, Bidhannagar,
Kolkata 700106

**Sub: Submission of Utilization Certificate for Operation & Maintenance of
Shelter for Urban Homeless under DAY- NULM at Habra Municipality.**

Sir,

With reference to above, I am submitting herewith the utilization certificate for Operation & Maintenance of shelter for urban homeless under Deendayal Antyodaya Yojana - National Urban Livelihoods Mission (DAY - NULM) for the month of March-May 2019.

Thanking You

Encl: As stated

Yours faithfully,

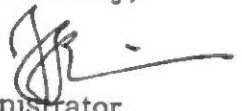
Administrator
Habra Municipality
Administrator
HABRA MUNICIPALITY

FORM SR-330A

Of the Treasury Rules, West Bengal and the Subsidiary Rules
made there under, Volume - I

FORM OF UTILISATION CERTIFICATE

Sl No.	Letter No. and Date	Amount (Rs.)
01.	SUDA-140/2015/3404 Dated: 23/04/2019	1,20,725.00
Total		1,20,725.00

Certified that out of Rs. 1,20,725.00 Grants-in-aid sanctioned for Operation & Maintenance of Shelter for Urban Homeless under SUH-DAY-NULM for the month of March, April, May 2019 towards Habra Municipality under this letter no. given in the margin and a sum of Rs. 1,20,725.00 only has been utilized for which it was sanctioned and the balance NIL remains unutilized in the hand at the end of 10/07/2019.

Certified that I have satisfied myself that the conditions on which the grants-in-aid was sanctioned have been duly fulfilled and that I have exercised the following check to see that the money was actually utilized for the purpose for which it was sanctioned.

Kinds of checks exercised:

1. Bank Pass Book
2. Cash Book
3. Measurement Book

Finance Officer
Habra Municipality

Manager
Social Dev. & Infrastructure
DAY-NULM, HABRA MUNICIPALITY

City Project Officer
DAY-NULM, HABRA MUNICIPALITY

Signature: 
Designation: Administrator
Habra Municipality
Administrator
HABRA MUNICIPALITY



HABRA MUNICIPALITY

(ESTD.-1979)

POURA BHAWAN

PROMODE DASGUPTA SARANI, P.O. HIJALPUKURIA, NORTH 24 PARGANAS, PIN - 743271
email : habramunicipality@yahoo.com

Ref. No. HM/0255/NULM/19

Date 06-05-2019

To
The Director SUDA &
Mission Director WBSULM
State Urban Development Agency
ILGUS BHAWAN
HC Block, Sector III, Bidhannagar
Kolkata- 700106

Sub: Submission of Monthly monitoring Report of Shelter for Urban Homeless under Habra Municipality.

Sir,

This is to inform you that the shelter for urban homeless under DAY-NULM of Habra Municipality is functional, hence I am sending with this letter the monthly monitoring report of shelter for urban homeless.

Thanking You

Yours faithfully

Kaushik City Project Officer (DAY-NULM)
Habra Municipality

City Project Officer
DAY-NULM, HABRA MUNICIPALITY

Shelter for Urban Homeless (SUH) monitoring Report

Name of the ULB:	HABRA
Whether Shelter is functional Yes/No	Yes
If Yes, Start Date	28/02/2019
Operated by: ULB/ Agency	Agency
If Agency, then Name of the Agency	Purbachal Amanda Foundation
Whether Shelter Management Committee (SMC) has been formed Yes/ No	Yes
If yes, Date of Formation	30/11/2018
No. of Persons identified and rescued	
Number of Inmates	Male: 3 Female: 9 Children: 0 Total: 12
No of Physically Challenged Person	No
Whether Health Check Up for Inmates Done Yes/ No, If yes, how regular:	Yes, Monthly
Whether details of Inmates shared with the Local Police Station Yes/No If No, then why:	Yet to be shared
Whether Daily Registers are maintained for Inmates Yes/No	Yes
Any user fees is collected from inmates, Yes/ No	No
No of Staffs provided in the SUH	2
Whether Attendance Register for Staffs available (Details of the Staffs: Name, Designation, and Mobile No.) Yes/ No	Yes

Whether food is provided to sick, aged, infirm, physically/mentally challenged Inmates Yes/No	Yes
Whether adequate bathing and toilet facility available Yes/ No	Yes
Whether 24 x 7 Electric Supply is provided Yes/ No	Yes
Regular monitoring & Supervision done by SMC Yes/ No	Yes
Whether initiatives are taken regularly to identify and rescue the Homeless	Yes
Whether regular public information/ IEC is displayed Bus stand/ Railway Station/Market places/ Place of worship etc.	Yet to be done
Any programme undertaken for mental recreation of inmates	NA
Any steps taken for financial inclusion and tie up with other Government benefit available	Yet to be done
Social Entitlement of Inmates (IGNOAPS/IGNWPS/IGNDPS)	2

Signature
06/05/2019

Signature
City Mission Manager (SDI)
Manager
Social Dev. & Infrastructure
DAY-NULM, HABRA MUNICIPALITY

Signature
06/05/19

Signature
City Project Officer
City Project Officer
DAY-NULM, HABRA MUNICIPALITY



HABRA MUNICIPALITY

(ESTD.-1979)

POURA BHAWAN

PROMODE DASGUPTA SARANI, P.O. HIJALPUKURIA, NORTH 24 PARGANAS, PIN - 743271
email : habramunicipality@yahoo.com

Phone No. : 03216 270572
Fax No. : 03216 237031

Ref. No. HM/0255/NULM/19

Date 06-05-2019

To
The Director SUDA &
Mission Director WBSULM
State Urban Development Agency
ILGUS BHAWAN
HC Block, Sector III, Bidhannagar
Kolkata- 700106

Sub: Submission of Monthly monitoring Report of Shelter for Urban Homeless under Habra Municipality.

Sir,

This is to inform you that the shelter for urban homeless under DAY-NULM of Habra Municipality is functional, hence I am sending with this letter the monthly monitoring report of shelter for urban homeless.

Thanking You

Yours faithfully

~~Kausik~~ City Project Officer (DAY-NULM)
Habra Municipality

City Project Officer
DAY-NULM, HABRA MUNICIPALITY

Shelter for Urban Homeless (SUH) monitoring Report

Name of the ULB:	HABRA
Whether Shelter is functional Yes/No	Yes
If Yes, Start Date	28/02/2019
Operated by: ULB/ Agency	Agency
If Agency, then Name of the Agency	Purbachal Amanda Foundation
Whether Shelter Management Committee (SMC) has been formed Yes/ No	Yes
If yes, Date of Formation	30/11/2018
No. of Persons identified and rescued	.
Number of Inmates	Male: 3 Female: 9 Children: 0 Total: 12
No of Physically Challenged Person	No
Whether Health Check Up for Inmates Done Yes/ No, If yes, how regular:	Yes, Monthly
Whether details of Inmates shared with the Local Police Station Yes/No If No, then why:	Yet to be shared
Whether Daily Registers are maintained for Inmates Yes/No	Yes
Any user fees is collected from inmates, Yes/ No	No
No of Staffs provided in the SUH	2
Whether Attendance Register for Staffs available (Details of the Staffs: Name, Designation, and Mobile No.) Yes/ No	Yes

Whether food is provided to sick, aged, infirm, physically/mentally challenged Inmates Yes/No	Yes
Whether adequate bathing and toilet facility available Yes/ No	Yes
Whether 24 x 7 Electric Supply is provided Yes/ No	Yes
Regular monitoring & Supervision done by SMC Yes/ No	Yes
Whether initiatives are taken regularly to identify and rescue the Homeless	Yes
Whether regular public information/ IEC is displayed Bus stand/ Railway Station/Market places/ Place of worship etc.	Yet to be done
Any programme undertaken for mental recreation of inmates	NA
Any steps taken for financial inclusion and tie up with other Government benefit available	Yet to be done
Social Entitlement of Inmates (IGNOAPS/IGNWPS/IGNDPS)	2

Signature
06/05/2019

Signature
City Mission Manager (SDI)
Manager
Social Dev. & Infrastructure
DAY-NULM, HABRA MUNICIPALITY

Signature
06/05/19

Signature
City Project Officer
City Project Officer
DAY-NULM, HABRA MUNICIPALITY

O/C

Phone No. : 03216 270572
Fax No. : 03216 237031

HABRA MUNICIPALITY

(ESTD.-1979)

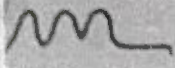

POURA BHAWAN

DASGUPTA SARANI, P.O. HIJALPUKURIA, NORTH 24 PARGANAS, PIN - 743271
email : habramunicipality@yahoo.com

21.6.3./NULM./19

Date22/04/2019.....

Chief Engineer
Engineering Directorate
North 24 Parganas Division
North 24 Parganas

Submission of Utilization Certificate for construction of 50 Bedded, 4
shelter for Urban Homeless under DAY- NULM at Habra Municipality.

In reference to above, I am submitting herewith 06 (six) sets of utilization certificate for construction of 50 bedded, 4 storied shelter for urban homeless under Deendayal Jyoti Jyoti - National Urban Livelihoods Mission (DAY - NULM) at Ward no. 22, Habra Municipality for your kind approval and necessary action.

Thanking You

Yours faithfully,

Administrator
Habra Municipality
Administrator
HABRA MUNICIPALITY



22/4/19





Government of West Bengal
Office of the Executive Engineer, North 24-Parganas Division,
Municipal Engineering Directorate
7, K.B. Bose Rd. (2nd floor) Barasat, North 24-Pgs
Kolkata-700 124
Phone No.:- (033) 2584-4288
Email :- north24pgsdivisionmed@gmail.com

No. : MED/PRG-1/

/1N-08/16

Date:- 23.04.2019

To
The Chief Engineer,
M. E. Dte.
Bikash Bhavan(1st floor)
Salt Lake City
Kolkata – 700 091



JD
Saf
Sourav

Sub : Submission of Utilisation Certificate for construction of 50 bedded, 4 storied Shelter for Urban Homeless under DAY-NULM for the town **Habra** under the jurisdiction of North 24-Parganas Division.

Ref. : Chairman's office memo no. HM/0167/NULM/19 dt.22.04.2019

Sir,

Enclosed please find herewith the Utilisation Certificate in duplicate for construction of 50 bedded, 4 storied Shelter for Urban Homeless under Deendayal Antyodaya Yojana – National Urban Livelihoods Mission (DAY-NULM) at ward no. 22 as submitted by the Chairman, Habra Municipality and duly checked by this end for favour of your kind information and taking necessary action.

Thanking you,
Encl. : As stated

Yours faithfully,

Executive Engineer
North 24-Pgs. Division, M.E.Dte.

No. : MED/PRG-1/ 72 (2) /1N-08/16

Date:- 23.04.2019

Copy forwarded for information to :

- 1) The Chairman, Habra Municipality– along with a copy of U.C.
- 2) The Director, SUDA, Ilgus Bhavan, Salt Lake City, Kolkata – along with 2 (Two) copies of U.C.
- 3) The Superintending Engineer, East Circle, M.E.Dte., AB - 30/1, Prafullya Kanan (West), Krishnapur, Baguiati, Kolkata – 700101

23/4/19
Executive Engineer
North 24-Pgs. Division, M.E.Dte.
Municipal

GFR 12 -C
[[See Rule 239]]

UTILIZATION CERTIFICATE
(Where expenditure incurred by Govt. bodies only)

For Construction of SUH for the F.Y. 18-19

Sl. No.	Letter No. and date	Amounts Rs.	
1.	SUDA-23/2014(Pt.)/1048 dated: 19/07/2016	48,90,000	Certified that out of Rs. 97,80,000 (Rupees ninety seven lakh eighty thousand only) of grant sanctioned during the year 2016 -17 & 2017-18 in favour of Habra Municipality North 24 Parganas Letter No. given in the margin and NIL on account of unspent balance of previous year, a sum of 50,56,017 (Rupees fifty lakh fifty six thousand seventeen only) has been utilized for the purpose of Construction of SUH for which it was sanctioned and that the balance of 47,23,983 (Rupees forty seven lakh twenty three thousand nine hundred eighty three only) remaining unutilized at the end of the year will be adjusted/utilized in next year.
2.	SUDA-23/2014(pt - II)/1425 dated: 04/12/2018	48,90,000	
	Total	97,80,000	

2. Certified that I have satisfied myself that the conditions on which the grants-in-aid was sanctioned have been duly fulfilled and that I have exercised the following checks to see that the money was actually utilized for the propose for which it was sanctioned.

Kinds of checks exercised:

Examination of 1. Vouchers, 2. Cash Book, 3. Ledger, 4. Statement of Expenditure & 5. Statement of Fund Position

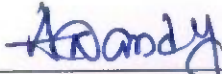

Signature of Accountant (DAY-NULM),
Habra Municipality

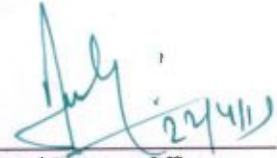

Signature of Finance Officer
Habra Municipality
Finance Officer
Habra Municipality

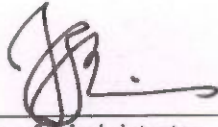

Signature of Administrator
Habra Municipality
Administrator
HABRA MUNICIPALITY

CS
Haber 23/4/19

Signature of Executive Engineer,
M.E. Dte., North 24 Parganas Division, Barasat

Executive Engineer
North 24- Parganas Division
Municipal Engineering Directorate
Deptt. of U.D. & M.A.
Government of West Bengal

GFR 12 - C
[[See Rule 239]]

UTILIZATION CERTIFICATE
(Where expenditure incurred by Govt. bodies only)

For Construction of SUH for the F.Y. 18-19

Sl. No.	Letter No. and date	Amounts Rs.	
1.	SUDA-23/2014(Pt.)/1048 dated: 19/07/2016	48,90,000	Certified that out of Rs. 97,80,000 (Rupees ninety seven lakh eighty thousand only) of grant sanctioned during the year 2016 -17 & 2017-18 in favour of Habra Municipality North 24 Parganas Letter No. given in the margin and NIL on account of unspent balance of previous year, a sum of 50,56,017 (Rupees fifty lakh fifty six thousand seventeen only) has been utilized for the purpose of Construction of SUH for which it was sanctioned and that the balance of 47,23,983 (Rupees forty seven lakh twenty three thousand nine hundred eighty three only) remaining unutilized at the end of the year will be adjusted/utilized in next year.
2.	SUDA-23/2014(pt - II)/1425 dated: 04/12/2018	48,90,000	
	Total	97,80,000	

2. Certified that I have satisfied myself that the conditions on which the grants-in-aid was sanctioned have been duly fulfilled and that I have exercised the following checks to see that the money was actually utilized for the propose for which it was sanctioned.

Kinds of checks exercised:

Examination of 1. Vouchers, 2. Cash Book, 3. Ledger, 4. Statement of Expenditure & 5. Statement of Fund Position



Signature of Accountant (DAY-NULM),
Habra Municipality



Signature of Finance Officer
Habra Municipality

Finance Officer
Habra Municipality

cls

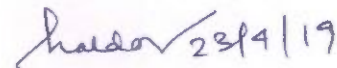

Signature of Executive Engineer,
M.E. Dte., North 24 Parganas Division, Barasat

Executive Engineer
North 24- Parganas Division
Municipal Engineering Directorate
Deptt. of U.D. & M.A.
Government of West Bengal



Signature of Administrator
Habra Municipality
HABRA MUNICIPALITY

সুডা**রাজ্য নগর উন্নয়ন সংস্থা****SUDA****STATE URBAN DEVELOPMENT AGENCY**

“ইলগাস ভবন”, এইচ-সি ব্লক, সেক্টর-৩, বিধাননগর, কলকাতা-৭০০ ১০৬, পশ্চিমবঙ্গ

“ILGUS BHAVAN”, H-C Block, Sector - III, Bidhannagar, Kolkata - 700 106, West Bengal

ক্রমিক নং
SUDA-118/16/ 3388তারিখ
18.04.2019

From : Director, SUDA

To : The Manager,
State Bank of India,
Salt Lake City, Kolkata - 700 091.**Sub: Electronic Transfer of Fund debiting this office
Current Account No. 37715094723****Shelter for Urban Homeless under NULM**

Sir,

You are requested to kindly arrange for electronic transfer of funds as per details given below debiting the amounts from this office Current Account No. **37715094723** lying with your branch in respect of **O&M cost of SUH under DAY-NULM**.

Sl. No.	Name of Payee	Amount (In Rs.)	Payees' Bank Details
01	Habra Municipality	1,20,725.00	State Bank Of India, Banipur Branch, A/C No. 35156397259, IFS Code. SBIN0016644
TOTAL		1,20,725.00	
(Rupees One lakh twenty thousand seven hundred twenty five only)			

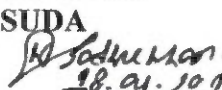
(Md Asif Sardar)
Finance Officer
SUDA
(Petrus Anuranjan Soreng)
Finance Officer
SUDA
28.04.2019

দূরভাষ : ২৩৫৮ ৬৪০৩ / ৫৭৬৭, ফ্যাক্স : ২৩৫৮ ৫৮০০

Tel : 2358 6403/5767, Fax : 2358 5800, E-mail : wbsudadir@gmail.com

Account Section : 2358 6408

STATE URBAN DEVELOPMENT AGENCY
National Urban Livelihood Mission (NULM)
 Group Summary
 1-Apr-2018 to 27-Mar-2019

Particulars	Closing Balance	
	Debit	Credit
Capacity Building and Training (CB & T) Under NULM	62,76,857.00	7,42,08,863.00
Remuneration of CMMs Under CB & T - NULM		1,67,97,849.00
Remuneration of C.O. Under CB & T-NULM		68,70,729.00
Remuneration of Support Staff Under CB & T-NULM		38,21,135.00
Remuneration of T.P.O. Under CB & T-NULM		10,80,000.00
Tech. Sup. at Nat, ST & CT Levels Under CB&T-NULM	62,76,857.00	
Training & Other CBP for MMUs Under CB&T-NULM		4,56,39,150.00
Emp. by Skill Trg. & Placement (EST&P) Under NULM		11,44,17,530.00
Assessment & Certification of Training (EST&P-NULM)		4,27,21,000.00
Emp. by Skill Trg. & Placement Under EST&P-NULM		7,16,96,530.00
Self-Employment Programme (SEP) Under NULM		1,09,04,877.00
Self-Emp. Ind. & Grp. Enterprises Under SEP-NULM		8,51,000.00
SHG-Bank Linkage Under SEP-NULM		1,00,03,877.00
Technology, Mktg. & Other Support Under SEP-NULM		50,000.00
Shelter for Urban Homeless (SUH)		4,97,03,673.00
Construction of Shelters for Urban Homeless - NULM		4,40,50,232.00
Interest on Shelter for Urban Homeless (SUH) - NULM		8,18,318.00
Operation & Maintenance of SUH-NULM		48,35,123.00
Social Mobilisation & Inst. Dev. (SM&ID) Under NULM		7,76,55,809.13
Bldg. Comm. Inst.:SGHs & Fed. Under SM&ID-NULM		66,58,009.13
City Livelihood Centres (CLCs) Under SM&ID-NULM		30,10,258.00
Fund Support to RO Under SM&ID-NULM		38,45,240.00
Printing of Books of A/Cs for ALF, SHG & CLF-SM & ID		38,28,552.00
Rev. Fund Support to ALF Under SM&ID-NULM		38,00,000.00
Rev. Fund Support to SHGs Under SM&ID-NULM		18,20,000.00
Trg. & Other CBP for SHGs & Fed. Under SM&ID-NULM		4,97,23,750.00
Universal Financial Inclusion Under SM&ID-NULM		49,70,000.00
A & OE Support to ULBs Under NULM		29,94,100.00
Information, Education & Commn (IEC) Under NULM		2,10,99,000.00
Interest on NULM		4,00,63,645.50
Support to Urban Street Vendors (SUSV) Under NULM		1,00,00,000.00
Grand Total	62,76,857.00	40,10,47,497.63

Bank 27.3.19



HABRA MUNICIPALITY

(ESTD.-1979)

POURA BHAWAN

PROMODE DASGUPTA SARANI, P.O. HIJALPUKURIA, NORTH 24 PARGANAS, PIN - 743271
email : habramunicipality@yahoo.com

Ref. No. H.M./3090./NULM/19

Date 08/03/2019



JD
S. Kumar

To
The Director SUDA & Mission Director, WBSULM
ILGUS Bhawan, HC-Block,
Sector III, Bidhannagar,
Kolkata 700106

Requisition of fund for Operation & Maintenance of "Bibekananda Bhawan" - SUH under DAY-NULM

Madam,

With reference to the above this is to inform you that Habra Municipality has inaugurated 50 bedded shelter for urban homeless - "Bibekananda Bhawan" on 28th February 2018. The shelter will be functional from 11/03/2019 and will be run by Purbachal Ananda Foundation. There are 19 beneficiaries presently identified for SUH. The detailed requisition for functioning the same is mentioned below:

Sl No	Item	Quantity	Unit	Rate Rs.	Amount Rs.
1.	Annual Maintenance Cost of Shelter				
i.	Electricity Charges	3	months	5000.00	15,000.00
ii.	Maintenance of plumbing & electrical work	3	months	500.00	1500.00
2.	Annual Servicing Cost				
i.	Sweeping Charges	3	months	3000.00	9,000.00
ii.	Replenishment of bedding	10%	Of capital cost for 3 months		3,124.99
3.	Cost of providing free food for 10% of inmates who are old/infirm and cannot pay (19*90*10%)	(19*90*10%)	days	100.00	17,100.00
4.	Staff Salary				
i.	Manager (full time)	3	months	10000.00	30,000.00
ii.	Caregivers: 3 nos. for 3 shifts of 8 hours	3 X 3=9	months	5000.00	45,000.00
Total					1,20,724.99

Therefore I request you to kindly look into the matter and release the fund required for operation & maintenance of SUH for smooth functioning of the same.

Thanking You

Yours faithfully

[Signature]

[Signature]
Administrator
Habra Municipality
Administrator
Habra Municipality



HABRA MUNICIPALITY

(ESTD.-1979)

POURA BHAWAN

PROMODE DASGUPTA SARANI, P.O. HIJALPUKURIA, NORTH 24 PARGANAS, PIN - 743271
email : habramunicipality@yahoo.com

Ref. No. HM/3089/NULM/19



Date 08/03/2019

To
The Director SUDA & Mission Director, WBSULM
ILGUS Bhawan, HC-Block,
Sector III, Bidhannagar,
Kolkata 700106



JD
Soumen Das

Requisition of fund for 3% contingency of Civil part of "Bibekananda Bhawan" - 50 bedded Shelter for urban homeless under DAY-NULM

Madam,

With reference to the above this is to inform you that Habra Municipality has completed the construction of 50 bedded shelter for urban homeless and has been inaugurated on 28th February 2019.

Hence, we request you to kindly release the 3% contingency of civil part of 50 bedded shelter for urban homeless under DAY-NULM amounting to INR 2,56,641.80 (Rupees two lakh fifty six thousand six hundred forty one and eighty paisa) only.

Request you to kindly look into the matter and release the required fund.

Thanking you

Yours faithfully

Basu
JB
Administrator
Habra Municipality
Administrator
Habra Municipality

HABRA MUNICIPALITY

(ESTD.-1979)

POURA BHAWAN

PROMODE DASGUPTA SARANI, P.O. HIJALPUKURIA, NORTH 24 PARGANAS, PIN - 743271
email : habramunicipality@yahoo.com

Ref. No. HM/3090./NULM./19



Date08/03/2019.....

To
The Director SUDA & Mission Director, WBSULM
ILGUS Bhawan, HC-Block,
Sector III, Bidhannagar,
Kolkata 700106

Requisition of fund for Operation & Maintenance of "Bibekananda Bhawan" - SUH under DAY-NULM

Madam,

With reference to the above this is to inform you that Habra Municipality has inaugurated 50 bedded shelter for urban homeless - " Bibekananda Bhawan" on 28th February 2018. The shelter will be functional from 11/03/2019 and will be run by Purbachal Ananda Foundation. There are 19 beneficiaries presently identified for SUH. The detailed requisition for functioning the same is mentioned below:

Sl No	Item	Quantity	Unit	Rate	Amount
				Rs.	Rs.
Annual Maintenance Cost of Shelter					
1.	Electricity Charges	3	months	5000.00	15,000.00
ii.	Maintenance of plumbing & electrical work	3	months	500.00	1500.00
Annual Servicing Cost					
i.	Sweeping Charges	3	months	3000.00	9,000.00
ii.	Replenishment of bedding	10%	Of capital cost for 3 months		3,124.99
3.	Cost of providing free food for 10% of inmates who are old/infirm and cannot pay (19*90*10%)	(19*90*10%)	days	100.00	17,100.00
Staff Salary					
i.	Manager (full time)	3	months	10000.00	30,000.00
ii.	Caregivers: 3 nos. for 3 shifts of 8 hours	3 X 3=9	months	5000.00	45,000.00
Total					1,20,724.99

Therefore I request you to kindly look into the matter and release the fund required for operation & maintenance of SUH for smooth functioning of the same.

Thanking You



Yours faithfully

Administrator
Habra Municipality
Administrator
Habra Municipality



HABRA MUNICIPALITY

(ESTD.-1979)

POURA BHAWAN

PROMODE DASGUPTA SARANI, P.O. HIJALPUKURIA, NORTH 24 PARGANAS, PIN - 743271
email : habramunicipality@yahoo.com

Ref. No.

Date

To
Purbachal Ananda Foundation
2/32 Purbachal
Durgapur-713201
Paschim Bardhaman, W.B.



JD
Soumen De
25/2

Sub: Selection for Operation & Maintenance of 'Vivekananda Bhawan' - Shelter for Urban Homeless under DAY-NULM at Habra Municipality.

Ref.: HM/2711(1-6)/NULM/19 dated: 30/01/2019

This is to inform that as per decision of Shelter Management Committee for selection of NGO for operation & maintenance of 'Vivekananda Bhawan'-Shelter for Urban Homeless under Deendayal Antyodaya Yojana - National Urban Livelihoods Mission at Habra Municipality, your organization has been selected for the same.

A memorandum of understanding will be signed between Habra Municipality and your organization. You are requested to commence the work from the day of the inauguration of 'Vivekananda Bhawan'. You are requested to bring 2 (two) non-judicial stamp paper of value INR 10/- (Rupees ten) only for signing of MoU.

sd/ Administrator
Habra Municipality

(Memo No. HM/2867/NULM/19 date 19/02/19)

Copy forwarded for information to:

- ✓ 1. Director, SUDA, ILGUS Bhawan, Salt-Lake, Kolkata 700106
2. Executive Officer/ City Project Officer (DAY-NULM), Habra Municipality
3. Finance Officer, Habra Municipality
4. Shri. Saroj Das, Sub-Assistant Engineer, Habra Municipality
5. Accountant/Head Clerk, Habra Municipality
6. Inspector-in-Charge, Habra Police Station
7. Shri. Shitangshu Das, Social Worker, Habra
8. Health Officer, Habra Municipality
9. Manager-Social Development & Infrastructure (DAY-NULM), Habra Municipality

Administrator
Habra Municipality
Administrator
Habra Municipality



HABRA MUNICIPALITY

(ESTD.-1979)

POURA BHAWAN

PROMODE DASGUPTA SARANI, P.O. HIJALPUKURIA, NORTH 24 PARGANAS, PIN - 743271
email : habramunicipality@yahoo.com

Ref. No. HM/2902/NULM/19



Date26/02/2019.....

To
The Director
State Urban Development Agency
ILGUS BHAWAN
H-C Block, Sector III
Bidhannagar, Kolkata - 700106

JD
JD

Sub: Invitation for inauguration of Shelter for Urban Homeless (Bibekananda Bhawan) under DAY-NULM scheme at Habra Municipality

Sir,

This is my pleasure to inform that Habra Municipality has successfully constructed 50 bedded Shelter for Urban Homeless under Deendayal Antyodaya Yojana – National Urban Livelihoods Mission scheme at Banipur, Ward no. 22 within Habra Municipality. The same will be inaugurated on 28th February 2019 at 5.00 P.M.

You are cordially invited to grace the programme with your august presence.

Thanking You

Yours faithfully

Date: 28/02/2019

Time: 5:00 P.M.

Venue: Bibekananda Bhawan,
Banipur, Ward No. 22

JD
Administrator
Habra Municipality

বিরেকানন্দ ভবন (SUH)

-এর স্তত উদ্বোধনে

১৮শে ফ্রেব্রুয়ারি, ২০১৯ বৃহস্পতিবার

স্থান : বাণীপুর, ২২নং ওয়ার্ড (সারদা ভবনের নিকটে), হাবড়া।

১৮



হাবড়া পৌরসভা

হাবড়া • উত্তর ২৪ পরগণা

গা.

State Director

State Urban Development Agency

বিবেকানন্দ ভবন (SUH)

-এর শুভ উদ্বোধনে

মহাশয় / মহাশয়া,

সমাজের অগ্রগতির পথে সকলের জন্য বাসস্থান একটি গুরুত্বপূর্ণ বিষয়। হাবড়া পৌরসভার ব্যবস্থাপনায় DAY-NULM (SUH)-প্রকল্পে সমাজের আর্থিকভাবে পিছিয়ে পড়া শহরের গৃহহীনদের জন্য “বিবেকানন্দ ভবন”। আগামী ২৮শে ফেব্রুয়ারি, ২০১৯ বৃহস্পতিবার বিকাল ৪টায় শুভ উদ্বোধন অনুষ্ঠিত হবে।



উদ্বোধক পশ্চিমবঙ্গ সরকারের খাদ্য ও সরবরাহ দপ্তরের মাননীয় মন্ত্রী **শ্রী জ্যোতিষ্ময় রাম্বিক মহাশয়**। প্রধান অতিথি হিসাবে উপস্থিত থাকবেন বারাসাত লোকসভা কেন্দ্রের সাংসদ মাননীয় **ডাঃ কবরলি ঘোষ দস্তিদার** মহাশয়া। অনুষ্ঠানের সভাপতিত্ব করবেন হাবড়া পৌরসভার প্রশাসক মাননীয় **শ্রী তাপস বিশ্বাস মহাশয়**। এছাড়াও উপস্থিত থাকবেন বিশিষ্ট ব্যক্তিবর্গ।

এই অনুষ্ঠানে আপনার সার্বিক উপস্থিতি ও সহযোগিতা একান্ত কাম্য।

ধন্যবাদান্তে -

আদিত্য মিত্রী

কার্তিক চন্দ্র দাস

অথ আধিকারিক

নিবাহী আধিকারিক

হাবড়া পৌরসভা

হাবড়া পৌরসভা

হাবড়া পৌরসভা



হাবড়া • উত্তর ২৪ পরগণা

স্থান :
বাগীপুর, ২২নং ওয়ার্ড
(সারাদা ভবনের নিকটে)



HABRA MUNICIPALITY

(ESTD.-1979)

POURA BHAWAN

PROMODE DASGUPTA SARANI, P.O. HIJALPUKURIA, NORTH 24 PARGANAS, PIN - 743271
email : habramunicipality@yahoo.com

Phone No. : 03216 270572
Fax No. : 03216 237031

Ref. No.

Date

To
Purbachal Ananda Foundation
2/32 Purbachal
Durgapur-713201
Paschim Bardhaman, W.B.

Sub: Selection for Operation & Maintenance of 'Vivekananda Bhawan'- Shelter for Urban Homeless under DAY-NULM at Habra Municipality.

Ref.: HM/2711(1-6)/NULM/19 dated: 30/01/2019

This is to inform that as per decision of Shelter Management Committee for selection of NGO for operation & maintenance of 'Vivekananda Bhawan'-Shelter fo Urban Homeless under Deendayal Antyodaya Yojana – National Urban Livelihoods Mission at Habra Municipality, your organization has been selected for the same.

A memorandum of understanding will be signed between Habra Municipality and your organization. You are requested to commence the work from the day of the inauguration of 'Vivekananda Bhawan'. You are requested to bring 2 (two) non-judicial stamp paper of value INR 10/- (Rupees ten) only for signing of MoU.

Administrator
Habra Municipality

(Memo No. HM/2867/NULM/19... date ...19/02/19...)

Copy forwarded for information to:

- ✓ Director, SUDA, ILGUS Bhawan, Salt-Lake, Kolkata 700106
2. Executive Officer/ City Project Officer (DAY-NULM), Habra Municipality
3. Finance Officer, Habra Municipality
4. Shri. Saroj Das, Sub-Assistant Engineer, Habra Municipality
5. Accountant/Head Clerk, Habra Municipality
6. Inspector-in-Charge, Habra Police Station
7. Shri. Shitangshu Das, Social Worker, Habra
8. Health Officer, Habra Municipality
9. Manager-Social Development & Infrastructure (DAY-NULM), Habra Municipality

Administrator
Habra Municipality
Administrator
Habra Municipality

Government of West Bengal
Office of the Executive Engineer, North 24-Parganas Division,
Municipal Engineering Directorate
7, K.B. Bose Rd. (2nd floor) Barasat, North 24-Pgs
Kolkata-700 124
Phone No.:- (033) 2584-4288
Email :- north24pgsdivisionmed@gmail.com

No. : MED/

Date:-

To
The Chief Engineer,
M. E. Dte.
Bikash Bhavan(1st floor)
Salt Lake City
Kolkata – 700 091

29 MAR 2018

Sub : Submission of Utilisation Certificate for construction of 50 bedded, 4 storied Shelter for Urban Homeless under DAY-NULM for the town **Habra** under the jurisdiction of North 24-Parganas Division.

Ref. : Chairman's office memo no. HM/4019/NULM/18 dt.28.03.2018

Sir,

Enclosed please find herewith the Utilisation Certificate in duplicate for construction of 50 bedded, 4 storied Shelter for Urban Homeless under Deendayal Antyodaya Yojana – National Urban Livelihoods Mission (DAY-NULM) at ward no. 22 as submitted by the Chairman, Habra Municipality and duly checked by this end for favour of your kind information and taking necessary action.

Thanking you,

Enclo. : As stated

Yours faithfully,

Executive Engineer
North 24-Pgs. Division, M.E.Dte.

No. : MED/ PRG-1/1741/1N-08/16

Date:- 29/03/18

Copy forwarded for information to :

- 1) The Chairman, Habra Municipality– along with a copy of U.C.
- 2) The Director, SUDA, Ilgus Bhavan, Salt Lake City, Kolkata – along with 2 (Two) copies of U.C.
- 3) The Superintending Engineer, East Circle, M.E.D., AB - 30/1, Prafullya Kanan (West), Krishnapur, Baguiati, Kolkata – 700101

Handwritten signature
Executive Engineer
North 24-Parganas Division
Municipal Engineering Directorate
Dept. of U.D. & M.A.
West Bengal

GOVERNMENT OF WEST BENGAL
OFFICE OF THE CHIEF ENGINEER
Municipal Engineering Directorate

Bikash Bhawan, South Block (1st Floor) Salt Lake, Kolkata – 700091

Phone No: (033)2337-1331/ (033)2358-3347 Fax: (033) 2337-5474

E-mail: ce_medte@yahoo.com

No. ME/ 175/ 4M-54/14-11

Dated: 19.04.18

From: The Chief Engineer,
Municipal Engineering Directorate.

To: The Director, SUDA,
ILGUS Bhaban, H.C. Block, Sector-III,
Salt Lake, Kolkata- 700 106.



DD
Sudip Bhowmik

Sub: Submission of Utilization Certificate for construction of 50 bedded, 4 storied Shelter for Urban Homeless under DAY-NULM programme within Habra Municipality

Sir,

Please find enclosed herewith the Utilization Certificate for construction of 50 bedded, 4 storied Shelter for Urban Homeless under NULM programme within Habra Municipality for favour of your kind information and taking further necessary action from your end.

Yours faithfully,

Encl: -As stated

19/4/18
Chief Engineer, M. E. Dte.

GFR 19-A
(See Rule 212 (1))
Form of Utilization Certificate

Sl. No.	Letter No. and date	Amount (in Rs.)
1.	SUDA-23/2014(Pt.)/1048 Dated: 19/07/2016	48,90,000/-
TOTAL		48,90,000/-
Rupees (Forty Eight Lakhs Ninety Thousand) only.		

Certified that out of **Rs 48,90,000/-** Grants-in-aid sanctioned during the year **2016-17** in favour of **Habra Municipality, North 24 Parganas** under this Ministry/Department letter No. given in the margin and Rs. **NIL** on account of unspent balance of the previous year, a sum of **Rs 17,05,334/-** only has been utilized for the purpose **construction of SUH** for which it was sanctioned and that the balance of **Rs 31,84,666 /-** remaining unutilized as on **29/03/2018**.

Certified that I have satisfied myself that the conditions on which the grants-in-aid was sanctioned have been duly fulfilled / are being fulfilled and that I have exercised the following checks to see that the money was actually utilized for the purpose for which it was sanctioned.

Kinds of Checks exercised.

01. Measurement Book maintained
02. Voucher & Cash Book maintained.
03. All other formalities observed.

Signature of F.O., Habra Municipality

Date: _____
Finance Officer
Habra Municipality

Signature of Chairman, Habra Municipality

Date: _____
CHAIRMAN
HABRA MUNICIPALITY

Signature of Executive Engineer, M.E.Dte.,GoWB

Date: _____
Executive Engineer
North 24 Parganas Division
Municipal Engineering Directorate
Deptt. of U.D. & M.A.
Government of West Bengal

GFR 19-A
(See Rule 212 (1))
Form of Utilization Certificate

Sl. No.	Letter No. and date	Amount (in Rs.)
1.	SUDA-23/2014(Pt.)/1048 Dated: 19/07/2016	48,90,000/-
TOTAL		48,90,000/-
Rupees (Forty Eight Lakhs Ninety Thousand) only.		

Certified that out of **Rs 48,90,000/-** Grants-in-aid sanctioned during the year **2016-17** in favour of **Habra Municipality, North 24 Parganas** under this Ministry/Department letter No. given in the margin and Rs. **NIL** on account of unspent balance of the previous year, a sum of **Rs 17,05,334/-** only has been utilized for the purpose **construction of SUH** for which it was sanctioned and that the balance of **Rs 31,84,666 /-** remaining unutilized as on **29/03/2018**.

Certified that I have satisfied myself that the conditions on which the grants-in-aid was sanctioned have been duly fulfilled / are being fulfilled and that I have exercised the following checks to see that the money was actually utilized for the purpose for which it was sanctioned.

Kinds of Checks exercised.

01. Measurement Book maintained
02. Voucher & Cash Book maintained.
03. All other formalities observed.

Signature of F.O., Habra Municipality

Date: _____ Finance Officer
Habra Municipality

Signature of Chairman, Habra Municipality

Date: _____ CHAIRMAN
HABRA MUNICIPALITY

Signature of Executive Engineer, M.E.Dte., GoWB

Date: _____ Executive Engineer
North 24- Parganas Division
Municipal Engineering Directorate
Deptt. of U.D. & M.A.
Government of West Bengal

Government of West Bengal
Office of the Executive Engineer, North 24-Parganas Division,
Municipal Engineering Directorate
7, K.B. Bose Rd. (2nd floor) Barasat, North 24-Pgs
Kolkata-700 124
Phone No.:- (033) 2584-4288
Email :- north24pgsdivisionmed@gmail.com

No. : MED/

Date:-

To
The Chief Engineer,
M. E. Dte.
Bikash Bhavan(1st floor)
Salt Lake City
Kolkata – 700 091



DD
Sudip Ghosh

Sub : Submission of Utilisation Certificate for construction of 50 bedded, 4 storied Shelter for Urban Homeless under DAY-NULM for the town **Habra** under the jurisdiction of North 24-Parganas Division.

Ref. : Chairman's office memo no. HM/4019/NULM/18 dt.28.03.2018

Sir,

Enclosed please find herewith the Utilisation Certificate in duplicate for construction of 50 bedded, 4 storied Shelter for Urban Homeless under Deendayal Antyodaya Yojana – National Urban Livelihoods Mission (DAY-NULM) at ward no. 22 as submitted by the Chairman, Habra Municipality and duly checked by this end for favour of your kind information and taking necessary action.

Thanking you,

Encl. : As stated

Yours faithfully,

Executive Engineer
North 24-Pgs. Division, M.E.Dte.

No. : MED/ PRG-1/1741/IN-08/16

Date:- 29/08/18

Copy forwarded for information to :

- 1) The Chairman, Habra Municipality– along with a copy of U.C.
- ✓ 2) The Director, SUDA, Ilgus Bhavan, Salt Lake City, Kolkata – along with 2 (Two) copies of U.C.
- 3) The Superintending Engineer, East Circle, M.E.D., AB - 30/1, Prafullya Kanan (West), Krishnapur, Baguiati, Kolkata – 700101

Shalor 29/3/18
Executive Engineer
North 24-Parganas Division
Municipal Engineering Directorate
Deptt. of U.D. & M.A.
Government of West Bengal

GFR 19-A
(See Rule 212 (1))
Form of Utilization Certificate

Sl. No.	Letter No. and date	Amount (in Rs.)
1.	SUDA-23/2014(Pt.)/1048 Dated: 19/07/2016	48,90,000/-
TOTAL		48,90,000/-
Rupees (Forty Eight Lakhs Ninety Thousand) only.		

Certified that out of **Rs 48,90,000/-** Grants-in-aid sanctioned during the year **2016-17** in favour of **Habra Municipality, North 24 Parganas** under this Ministry/Department letter No. given in the margin and Rs. **NIL** on account of unspent balance of the previous year, a sum of **Rs 17,05,334/-** only has been utilized for the purpose **construction of SUH** for which it was sanctioned and that the balance of **Rs 31,84,666 /-** remaining unutilized as on **29/03/2018**.

Certified that I have satisfied myself that the conditions on which the grants-in-aid was sanctioned have been duly fulfilled / are being fulfilled and that I have exercised the following checks to see that the money was actually utilized for the purpose for which it was sanctioned.

Kinds of Checks exercised.

01. Measurement Book maintained
02. Voucher & Cash Book maintained.
03. All other formalities observed.

Signature of F.O., Habra Municipality

Date: _____
Finance Officer
Habra Municipality

Signature of Chairman, Habra Municipality

Date: _____
CHAIRMAN
HABRA MUNICIPALITY

Signature of Executive Engineer, M.E.Dte., GoWB

Date: _____
Executive Engineer
North 24- Parganas Division
Municipal Engineering Directorate
Dept. of U.D. & M.A.
Government of West Bengal

GFR 19-A
(See Rule 212 (1))
Form of Utilization Certificate

Sl. No.	Letter No. and date	Amount (in Rs.)
1.	SUDA-23/2014(Pt.)/1048 Dated: 19/07/2016	48,90,000/-
TOTAL		48,90,000/-
Rupees (Forty Eight Lakhs Ninety Thousand) only.		

Certified that out of **Rs 48,90,000/-** Grants-in-aid sanctioned during the year **2016-17** in favour of **Habra Municipality, North 24 Parganas** under this Ministry/Department letter No. given in the margin and Rs. **NIL** on account of unspent balance of the previous year, a sum of **Rs 17,05,334/-** only has been utilized for the purpose **construction of SUH** for which it was sanctioned and that the balance of **Rs 31,84,666 /-** remaining unutilized as on **29/03/2018**.

Certified that I have satisfied myself that the conditions on which the grants-in-aid was sanctioned have been duly fulfilled / are being fulfilled and that I have exercised the following checks to see that the money was actually utilized for the purpose for which it was sanctioned.

Kinds of Checks exercised.

01. Measurement Book maintained
02. Voucher & Cash Book maintained.
03. All other formalities observed.

Signature of F.O., Habra Municipality

Date: _____
Finance Officer
Habra Municipality

Signature of Chairman, Habra Municipality

Date: _____
CHAIRMAN
HABRA MUNICIPALITY

Signature of Executive Engineer, M.E.Dte., GoWB

Date: _____
Executive Engineer
North 24 Parganas Division
Municipal Engineering Directorate
Deptt. of U.D. & M.A.
Government of West Bengal

SUMMARY OF DPR FOR SHELTER FOR URBAN HOME LESS

Name of the shelter with Ward
No: Shelter for Urban Homeless at
Ward No.-22

Name of ULB: Habra Municipality

Name of the City : Habra

Proposal for Construction or refurbishment:

No. of Shelters already sanctioned
(for Construction and refurbishment) - Nil

Capacity Proposed: 50

Proposed Location: Habra

Total Capacity of existing
Shelters
(i) Under NULM - NA
(ii) From Other schemes - NA
(iii) Total - NA

No. of existing Shelters
Operational in ULB:
(i) Under NULM - NIL
(ii) From Other schemes - NIL
(iii) Total - Nil

Sl. No	Parameters	Details	Remarks
1	Is the City a NULM city as per the norms of NULM?	Yes	
2	Total Population of the ULB as per the Census 2011 <i>(as mentioned in Para 3.2 of the SUH Guidelines)</i>	147290	
3	Brief Details of homeless survey (if any) giving year, agency, number of homeless identified etc. Locations having high concentration of homeless which this shelter will cover:	Survey list attached with DPR Railway Station, High School, Bus Stand, Market area	
5	Space in the proposed Shelter	1. Area (sq.m)	253.87 m ²
		2. Proposed capacity	50 persons
		3. Area per person	5.1 SQM
6	Please specify the group of Urban Homeless the Shelter Would cater to viz. (a) Men (b) Women/Single Women and their dependet Children (c) Children (d) aged (e) Mentally Disabled (f) Any other. <i>(as mentioned in Para 3.3 of the SUH Guidelines)</i>	(a) Men (b) Women/Single Women and their dependet Children (c) Children (d) aged (e) Mentally Disabled (f) Family	

7	Details Land on which Shelter is Proposed to be built <i>(as mentioned in Para 9.4 & 9.6 of the SUH Guidelines)</i>	Area	534.19 m ²
		J.L. No.	84
		Location	MOUZA-Asrafabad, WARD NO. - 22
		Owner of Land as per Land records	Municipality
8	Details of Lease /agreement /permission under which land is being used for Shelter:	N.A.	
9	Please specify the facilities to be provided in the Shelter: <i>(as mentioned in the para 4 of the SUH Guidelines)</i>	a) Well ventilated room	Yes
		b) Water and Sanitation Arrangements	Yes
		c) Standard Lighting	Yes
		d) Cleaning and Maintenance of other services	Yes
		e) Common Kitchen	Yes
		f) Any other	
10	Estimated Cost Of Shelter:	i) Site Development	
		ii) Civil Works including(internal electricity,sanitation and water)	109.10 lakhs
		iii) External electricity Connection	0.50 lakhs
		iv) External Water connection	
		v) Furniture and other equipments	8.71 lakhs
		vi) any other	7.52 lakhs
		vii)Total	125.82 lakhs
11	Type of Construction, Material etc.	RCC framed structure	
12	Rate proposed for Construction and refurbishment ; Specify whether the rate is as per Central Public Works (CPWD) rates or State Scheduled of Rates. <i>(as mentioned in the para 9.5 of the SUH guidelines).</i>	WB PWD SoR , 2014 w.e.f. 01.07.2014	
13	Weather the design is resistant to Earth Quake and similar Natural Calamities	Yes	

14	Proposed Date of Completion of Construction of Shelter with <i>Time Line (as mentioned in the para 9.3 of the SUH guidelines).</i>	one year	
15	Any other Financial Support for Construction ,refurbishment and or O&M of the Shelter Through any other source other than NULM . <i>(as mentioned in the para 9.1 & 9.2 of the SUH guidelines).</i>	Initially contribution of ULB will utilised towards O&M of shelter.	
16	Arrangement for convergence with other services/ entitlements.	Purely for Shelter for Homeless	
a)	Name of the Organization which has been identified for operations and Management of the proposed Shelter. Justify their selection <i>(as mentioned in the para 8.1 of the SUH guidelines).</i>	Habra Municipality	
b)	Details of the arrangement /Aggrement by which the Shelter is Proposed to be managed in the first five years of it's existence <i>(as mentioned in the para 9.8 of the SUH guidelines).</i>	Details arrangement to be made by Habra Municipality as per guideline of SUH	
c)	Details of cost estimates foe Operation and Management of the Shelter including Staff and theirsalaries <i>(as mentioned in the para 11.6 of the SUH guidelines) .</i>	Enclosed	
d)	Plan for sustaining the Shelter after 5 years of operation under NULM <i>(as mentioned in the para 9.8 of the SUH guidelines).</i>	Municipality will arrange fund for sustaning the Shelter after 5 years.	

Signature :
Name with seal of
the Implementing Agency:



HABRA MUNICIPALITY

(ESTD.-1979)

POURA BHAWAN

PROMODE DASGUPTA SARANI, P.O. HIJALPUKURIA, NORTH 24 PARGANAS, PIN - 743271
email : habramunicipality@yahoo.com

Phone No. : 03216 270572
Fax No. : 03216 237031

Ref. No.

Date

To
Purbachal Ananda Foundation
2/32 Purbachal
Durgapur-713201
Paschim Bardhaman, W.B.

Sub: Selection for Operation & Maintenance of 'Vivekananda Bhawan'- Shelter for Urban Homeless under DAY-NULM at Habra Municipality.

Ref.: HM/2711(1-6)/NULM/19 dated: 30/01/2019

This is to inform that as per decision of Shelter Management Committee for selection of NGO for operation & maintenance of 'Vivekananda Bhawan'-Shelter fo Urban Homeless under Deendayal Antyodaya Yojana – National Urban Livelihoods Mission at Habra Municipality, your organization has been selected for the same.

A memorandum of understanding will be signed between Habra Municipality and your organization. You are requested to commence the work from the day of the inauguration of 'Vivekananda Bhawan'. You are requested to bring 2 (two) non-judicial stamp paper of value INR 10/- (Rupees ten) only for signing of MoU.

Administrator
Habra Municipality

(Memo No. HM/2867/NULM/19... date 19/02/19..)

Copy forwarded for information to:

- ✓ Director, SUDA, ILGUS Bhawan, Salt-Lake, Kolkata 700106
2. Executive Officer/ City Project Officer (DAY-NULM), Habra Municipality
3. Finance Officer, Habra Municipality
4. Shri. Saroj Das, Sub-Assistant Engineer, Habra Municipality
5. Accountant/Head Clerk, Habra Municipality
6. Inspector-in-Charge, Habra Police Station
7. Shri. Shitangshu Das, Social Worker, Habra
8. Health Officer, Habra Municipality
9. Manager-Social Development & Infrastructure (DAY-NULM), Habra Municipality

Administrator
Habra Municipality
Administrator
Habra Municipality

TA
2/2/16

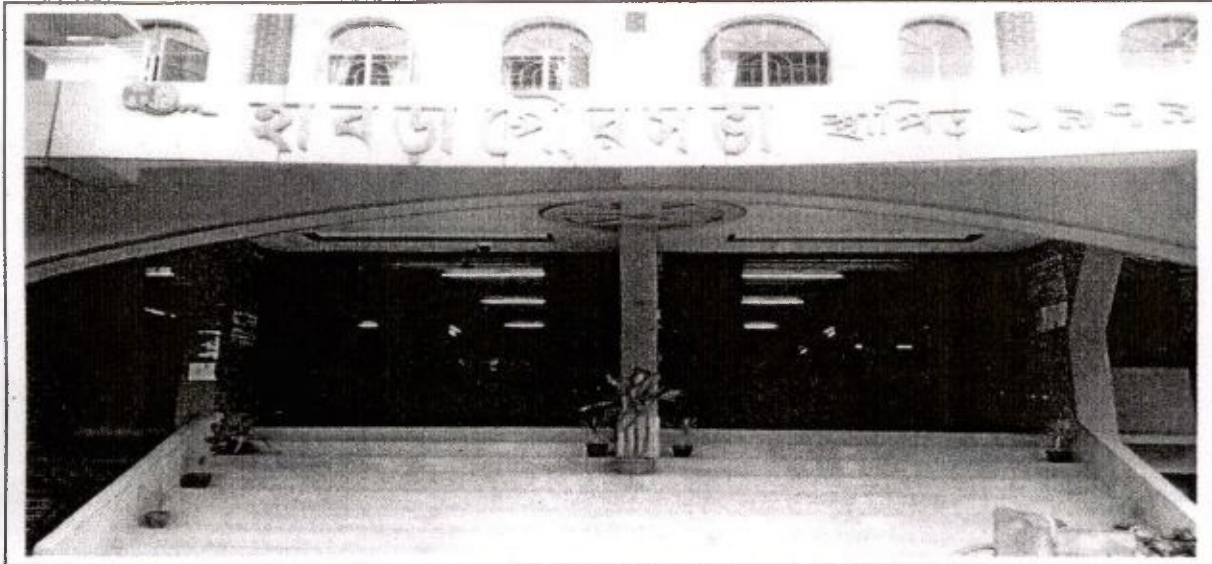

DETAILED PROJECT REPORT
SHELTER FOR URBAN HOMELESS UNDER NULM
HABRA MUNICIPALITY

July 2015



PROPOSED

SHELTER FOR URBAN HOMELESS

AT

BANIPUR, WARD NO.-22,

HABRA

UNDER

HABRA MUNICIPALITY

PROPOSED

SHELTER FOR URBAN HOMELESS

AT

BANIPUR, WARD NO.-22,

HABRA

UNDER

HABRA MUNICIPALITY

INDEX

i)	Preface	1-2
ii)	Project At a Glance	3
iii)	Town Feature	4-8
iv)	Location Maps	9-11
v)	Executive Summary	12
vi)	Estimate	13-22
vii)	Drawing	23-29
viii)	O & M Plan	30-31
ix)	Fund Flow	32
x)	Implementation Schedule	33
xi)	BOC	34
xii)	Land Document	35 -36
xiii)	Survey Report	Annexure-I(pg 1-3)

• Formulate structures and framework of engagement for development, management and monitoring of shelters and ensuring basic services to homeless persons, by state and civil society organisations including homeless collectives.

In pursuance of the decision taken by the West Bengal State Urban Livelihood Mission for setting up a "Shelter for Urban Homeless (SUH)" under National Livelihood Mission in Habra and with a view to providing shelter to the homeless people living in this town, The Habra Municipality has already been identified the land at Banipur, Ward No.-22 and the authority of the ULB has decided that one proposal would be sent to the SULM for setting up a shelter for urban poor in this site.

A survey was conducted for ascertaining the status of the urban homeless and 29 (twenty nine) homeless persons for the shelter have been identified at present. A project has been prepared in conformity with the objectives and a guideline issued in this regard, which includes interalia, construction of a four storied building with the provision of all amenities as envisaged in the scheme.

It is believed that the proposed project would not only provide shelter to the homeless people belonging to the most vulnerable segment of the society but also could ensure availability and access of those urban homeless people to various other entitlement like social security etc. besides the basic civic services like water supply, sanitation, electricity and primary health care etc.



Sub-Assistant Engineer
HABRA MUNICIPALITY



CHAIRMAN
HABRA MUNICIPALITY

PREFACE

The National Urban Housing & Habitat Policy (NUHHP), 2007 aims at promoting sustainable development of habitat in the country with a view to ensuring equitable supply of land, shelter and services at affordable prices to all sections of the society. However, the most vulnerable of these are the urban homeless.

The Urban homeless persons contribute to the economy of the cities and thus the nation as cheap labour in the informal sector; yet they live with no shelter or social security protection. The urban homeless survive with many challenges like no access to elementary public services such as health, education, food, water and sanitation.

National Urban Livelihoods Mission (NULM) aims at providing permanent shelter equipped with essential services to the urban homeless in a phased manner under the Scheme of Shelter for Urban Homeless (SUH).

The objectives of the Shelter for Urban Homeless (SUH) component of NULM scheme are to:

- ↓ Ensure availability and access of the urban homeless population to permanent shelters including the basic infrastructure facilities like water supply, sanitation, safety and security;
- ↓ Cater to the needs of especially vulnerable segments of the urban homeless like the dependent children, aged, disabled, mentally ill and recovering gravely ill, by creating special sections within homeless shelters and provisioning special service linkages for them.
- ↓ Provide access to various entitlements, viz. social security pensions, PDS, ICDS, identity, financial inclusion, education, affordable housing etc. for homeless populations.

Sub-Assistant Engineer
HABRA MUNICIPALITY

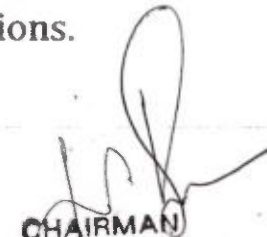
CHAIRMAN
HABRA MUNICIPALITY

PROJECT AT A GLANCE			
1	NAME OF TOWN	:	Habra
2	CATEGORY	:	Municipality
3	STATE	:	West Bengal
4	DISTRICT	:	24 Parganas North
5	ADMINISTRATIVE STATUS	:	Municipal Town
6	POPULATION (2011 CENSUS)	:	147290
7	AREA OF THE TOWN	:	21.80 SQ. KM.
8	SHELTER CAPACITY	:	50 PERSON
9	AREA STATEMENT		
i	AREA OF LAND		534.19 SQM
ii	COVERED AREA		184.16 SQM
iii	FLOOR AREA FOR DORMITORY /ROOM (GF+FF+2ndF+3rdF)		19.82+79.30+79.30+75.45= 253.87 SQM
10	AGENCIES		
	IMPLEMENTING AGENCY	:	Habra Municipality under technical guidance of MED
	O & M	:	Habra Municipality
	NODAL AGENCY	:	State Urban Development Agency
11	COSTING		
	COST FOR CIVIL STRUCTURE	:	Rs. Lakh 109.10
	COST FOR FURNITURE & UTENSILS	:	Rs. Lakh 8.71
	COST FOR OTHERS	:	Rs. Lakh 8.02
	TOTAL PROJECT COST	:	Rs. Lakh 125.82
	O & M COST FOR FIVE YEAR	:	Rs. Lakh 30.10
12	IMPLEMENTING PERIOD		
	COMMENCEMENT	:	2015
	COMPLETION	:	2016
13	FUNDING PATTERN		
	GOI	:	Rs. Lakh 116.87
	GOWB	:	Rs. Lakh 39.06

 Sub-Assistant Engineer
 HABRA MUNICIPALITY

 CHAIRMAN
 HABRA MUNICIPALITY

TOWN PROFILE

HABRA TOWN

HISTORICAL BACKGROUND

The town 'Habra' is not a very old settlement. It is situated within the Habra Police Station under Barasat Sub-Division of North 24-Parganas. The district, North 24-Parganas falls within the lower Gangetic belt of West Bengal. Massive influx of displaced persons since partition of the province of Bengal from the erstwhile East Pakistan, i.e. the then East Bengal settling in the area caused it to emerge out as a town. The refugees settled here and started small scale household industries and trading for their livelihood. This imparted the rural area an urban character. During the last few years Habra has been growing up rapidly as important growth centre marketing and trading activities along with small scale industries of the district. This way this urban nodal centre for civic, administration & socio-economic activities emerged out as a town. The municipality was constituted on 27th August, 1979. The town Habra predominantly refugee dominated, categorized as a 'Service-cum-Trade and Commerce' town as per 1981 census.

BASIC INFORMATION

LOCATION

The municipal town of Habra is located within the subdivision of Barasat in the District of North 24-Parganas. It is situated at a distance of 30 km. North of Barasat Sub-Division town, about 35 km. South of Bongaon Sub-Division town and is 60 km. North of state capital Kolkata. The town has developed just on both sides of Sealdah-Bongaon section of Eastern Railway Broad Gauge Line having a Railway Station 'Habra'. The National Highway (NH 35) named Jessore Road and Jeerut Road (State Highway) pass through this town. It is geographically positioned in the North-Eastern direction from the state capital, Kolkata.

AREA

The town covers an area of 21.80 sq.km. as per 2011 census. It comprises of 23wards, 13 mouzas and 31325 holdings.

POPULATION

The present population of the town is 147290 (as per 2011 census).

The population figures of the town with growth rate has been presented in the table-

Population (thousand)			Decadal Change in Population (%)	
1991	2001	2011	1991 - 2001	2001 - 2011
116.987	127.602	147.290	9.07	15.43

The growth of population of the town in the last decade has registered a increase of about 15.43% from the earlier decade which is nearly at par with that of urban growth rate of West Bengal as well as well as the district. The present trend of the growth of population suggests that there is a trend of migration from the nearby towns that will ultimately affect seriously unless proper infrastructures facilities are provided in time to cope with the needs for such urban growth in future.

Sub-Assistant Engineer
HABRA MUNICIPALITY

CHAIRMAN
HABRA MUNICIPALITY

CLIMATE AND RAINFALL

The climate of Habra usually possesses the same character as that of the Gangetic West Bengal. The months of April and May cover the hottest period and the months of December and January bear the coldest period. Monsoon normally sets in from the 2nd week of the month of June and persists upto the last week of September. Average rainfall of the town Habra remains around 1500 mm. Average maximum and minimum temperature are about 38°C and 11°C respectively.

TOPOGRAPHY AND SOIL

The soil condition of both the districts of North 24-parganas and South 24-Parganas is almost identical in nature in major part of the two districts. Except a small region within the Sundarban region, soil of the district is mostly composed of alluvial soil and the terrain is more or less flat.

EXISTING LAND USE

The town Habra has emerged out as an urban center as a result of settlement of refugee-migrants from the then East Pakistan. Such settlement occurred on and from 1947 i.e. the year of independence and also the year of partition of Bengal. The Municipality was established in the year 1979.

The existing land use pattern of the town is a mixed one. There is no such area which can be exclusively termed as commercial, industrial, residential or office zone. Everything has been developed admixing one to another. However the town is predominantly residential. Along the National Highway 35, State Highway and Town roads commercial activities are predominant with markets and shopping centres. There are some portion on the outskirts of the town which can be termed as agricultural area.

ADMINISTRATIVE SET UP

Habra is a Block under the Barasat Sub-Division in the District of 24 Parganas North.

COMMUNICATION

This town is 60 km. away from Kolkata. The town has well-connected transport facilities with Broad Gauge Railway line in the Sealdah-Bongaon Section of Eastern Railway. Apart from this railway connection, this town also enjoys good linkage by road transport. The most important thoroughfare is the Jessore Road (NH 35) serving as its artery. The hinterland as well as other Sub-Divisional towns are also well connected by the State Highway and National Highway.

The town has 8 post offices, one main post office at Habra. The town has been brought under the STD facilities by the Department of Telecommunication.

OCCUPATIONAL PATTERN & ECONOMIC BASE

About 60% of the town population belongs to service holder category.

Agriculture

The town is surrounded by highly fertile agricultural land, which produces a wide variety of vegetables and cash crops like Jute, Paddy, during all seasons. A good number of people around 15% are engaged in agricultural profession. The town is well known for its agricultural marketing and business centre.

Fishery

About 5% of the population is engaged in fishing activities.

Sub-Assistant Engineer
HABRA MUNICIPALITY

CHAIRMAN
HABRA MUNICIPALITY

INDUSTRY

There is no major industry in the town. The industrial activity is oriented to a few small scale industries such as Saw Mill, Husking Mill, Mini Rice Mill, Oil Mill Dal Mill, Manufacturing of Steel Furniture, Gate Grills, M. S. Wire Nail and Plastic Goods etc. The cottage industries are confined to Handloom, weaving and production of conch shells etc

SOCIAL INFRASTRUCTURE

POLICE AND FIRE STATION

This town has one police station and a '2-pump Fire Station'.

HEALTH FACILITY

The town has one Government hospital and six Nursing homes.

EDUCATIONAL FACILITY

There are two degree colleges, one post graduate B. T. College, Junior B. T. College, Janata College Physical Training College. Besides, there are five Higher Secondary Schools for boys, three Higher Secondary School for girls. There are 46 Primary Schools and 22 Nursery Schools. It had a literacy rate of 35 per 100 persons as per 1981 census. Its present literacy rate is 78.55%. Habra Municipality has a town library which was established by the municipality in the year 1981, in its own office premises. It was later sponsored by the Govt. of West Bengal. There are three more private libraries within the Municipality sponsored by the Government of West Bengal.

MARKET FACILITY

The municipality has 14 daily markets and 18 wholesale markets for dealing with daily commodities and retail cloth, jute, fruit & vegetable. It has no. of commercial centers. Considering the demand of the town as well as the transit population, the local Authority is planning to create some more Commercial Complexes at Habra in the fore coming days.

RECREATION

The town has 3 picnic spots at Banipur at ward no. 12, Jaygachi at ward no. 21 and Ayra at ward no. 1 which are used by large no. people (12000 almost) during season. The town has 3 nos. cinema halls. A large town hall at ward no. 14 is presently under construction by the Municipality. It has also passenger transit center for international tourists to and from Bangladesh by the road route.

ROAD SYSTEM

The National Highway no. 35 named Jessore Road, the State Highway named Jeerat Road pass through this town. G. B. Road, Nagarukhra Road, By-Pass Road and other Municipal Roads connect the surrounding areas of the town. At present there are 155.26 km. of roads within municipality.

DRAINAGE

Habra town has no underground sewerage system. The total no. of latrines in the town is 25500 but still approximately 5000 nos. are lying as open /dry latrine. This town has one trenching ground at the outskirts of



Sub-Assistant Engineer
HABRA MUNICIPALITY

**CHAIRMAN
HABRA MUNICIPALITY**

8. **Frequency of Bus Services** : Avg. 180 Per day
9. **Name of the rivers – waterways-lake etc. closeby** : Padma Nala, Bidyadhari, Cannel, Nangla Bill
10. **Is there any Industrial Estate in or close to the town** : No
11. **Details of Industrial Units / Workshops in the town** :
- a) Manufacture of plastic goods – 32 nos.
 - b) Manufacture of M.S. Wire Nail – 1 no.
 - c) Ice Industries – 2 nos.
 - d) Engineering Firm – 8 nos.
 - e) Gate Grill etc. – 19 nos.
 - f) Steel Furniture – 5 nos.
 - g) Oil Mill – 12 nos.
 - h) Mini Rice Mill – 23 nos.
 - i) Husking Mill – 11 nos.
 - j) Saw Mill – 16 nos.
 - k) Dal Mill – 9 nos.
12. **Electric Supply** : Yes, by WBSEB
13. **Mandi Establishment** : Yes, there are four vegetable markets in the town
14. **Municipal Market** : 4 markets & 2 Shopping centers
15. **No. of shops in the town** : 3500 nos. (approx.)
16. **Principal item of trade in the town & approximate turn over** : Rice, Agriculture Produces and Readymade Garments. Approximately 50 crore per annum.
17. **Trade links with no. of villages** : 110 villages.
18. **Future perspective** : The municipal town located in the border area of Indo-Bangladesh with increasing population strength, has tremendous potentiality for growth of business and scope for establishment of small scale industries in the private sectors, if infrastructure development works are undertaken.

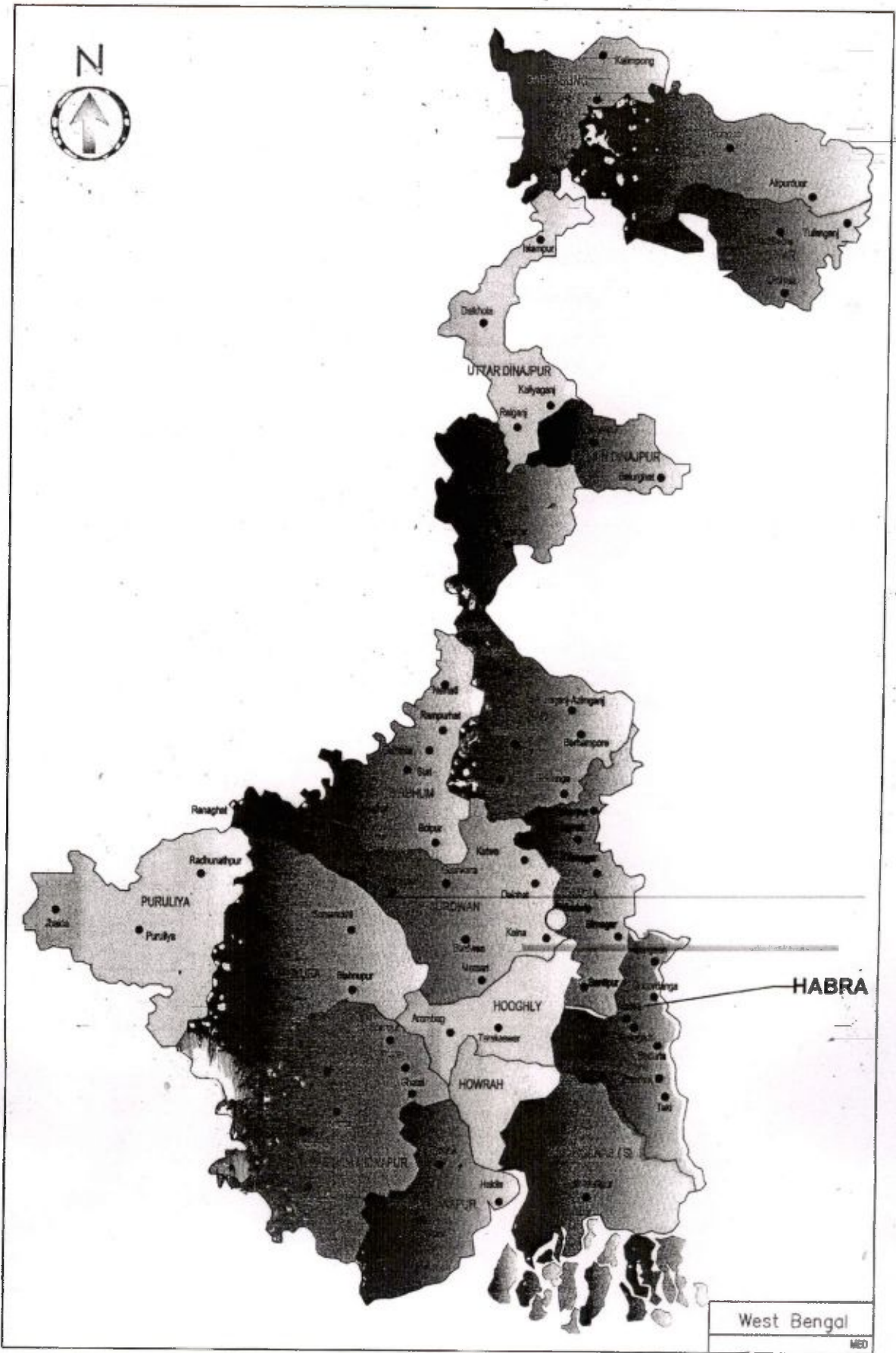

Sub-Assistant Engineer
HABRA MUNICIPALITY

CHAIRMAN
HABRA MUNICIPALITY

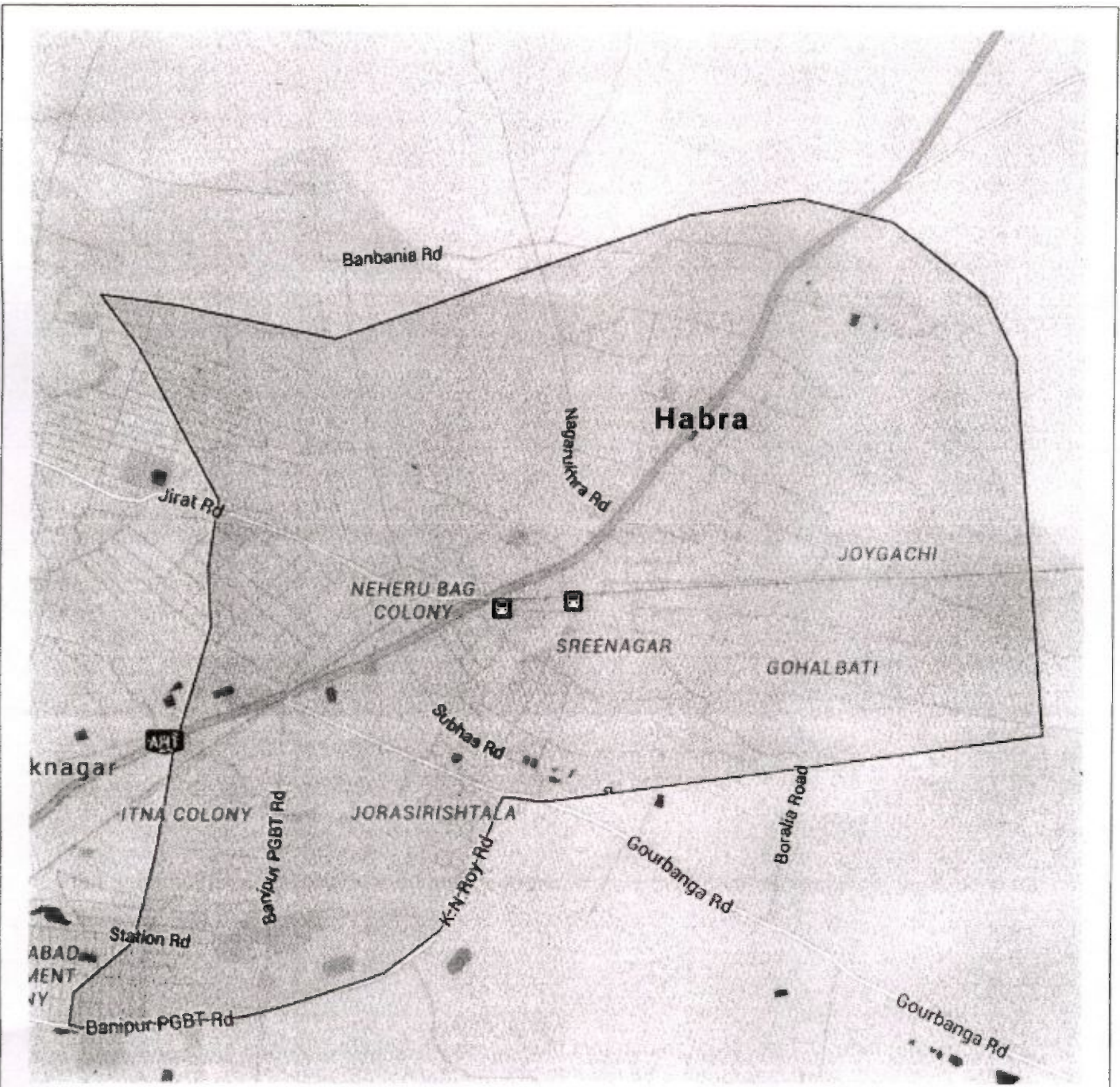

(Signature)
 Sub-Assistant Engineer
 HABRA MUNICIPALITY

(Signature)
 CHAIRMAN
 HABRA MUNICIPALITY



HABRA TOWN MAP



 Sub-Assistant Engineer
 HABRA MUNICIPALITY

 CHAIRMAN
 HABRA MUNICIPALITY

BASE MAP OF HABRA MUNICIPALITY

LEGEND

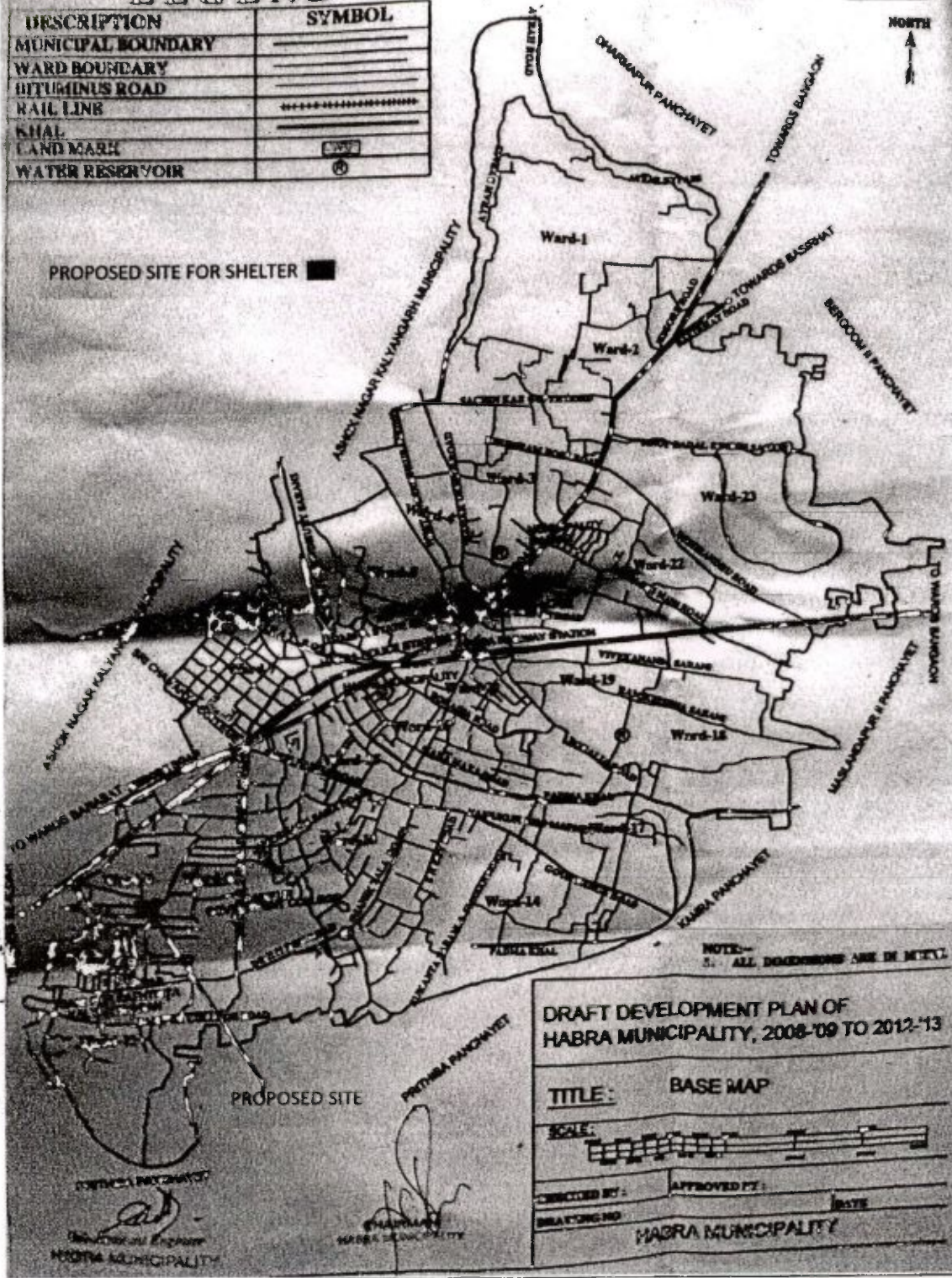
DESCRIPTION	SYMBOL
MUNICIPAL BOUNDARY	—————
WARD BOUNDARY	—————
BITUMINUS ROAD	—————
RAIL LINE	—————
KHAL	—————
LAND MARK	⊙
WATER RESERVOIR	⊙



PROPOSED SITE FOR SHELTER ■

NOTE:-
5. ALL DIMENSIONS ARE IN METRE

DRAFT DEVELOPMENT PLAN OF HABRA MUNICIPALITY, 2008-09 TO 2012-13

TITLE: BASE MAP

SCALE:

PREPARED BY:
APPROVED BY:
DRAWING NO:
DATE:

HABRA MUNICIPALITY

PROPOSED SITE LOCATION

Sub-Assistant Engineer
HABRA MUNICIPALITY

CHAIRMAN
HABRA MUNICIPALITY

EXECUTIVE SUMMARY

Project Details

1	State	:	West Bengal
2	City	:	Habra
3	Project Name	:	Shelter for Urban Homeless of Habra under NULM
4	Project Cost (Rs. In Lacs)	:	155.92
5	Central Share (Rs. In Lacs)	:	116.87
6	State Share (Rs. In Lacs)	:	39.06
7	SOR Adopted	:	PWD (WB) SoR w.e.f. 1.7.14

Project Contributions (Physical + Financial) (Rs. In lacs)

Sl No.	Scheme Component	Quantity	Unit	Rate (in Rs./unit)	Proposed project cost (in lakh)	Appraised Project Cost (in lakh)	Central Share	State Govt. Share
1	Construction of 50 beded four storied Shelter including Sanitary Plumbing and Internal Electrification.	1	No.	10909551.00	109.10	109.10	81.82	27.27
2	Cost for furniture and Utensils	1	No.	870500.00	8.71	8.71	6.53	2.18
3	Service Conections (WBSEDCL)	1	LS	50000.00	0.50	0.50	0.38	0.13
4	Fire fighting arrangement	1	LS	40000.00	0.40	0.40	0.30	0.10
Total Cost					118.70	118.70	89.03	29.68

Operation and maintenance cost

1	O & M Cost for maintenance of assets created for five year	5	Yrs	602000.00	30.10	30.10	22.50	7.60
---	--	---	-----	-----------	-------	-------	-------	------

Other Cost

1	DPR Preparation, project management, supervision & Quality control	% total cost		3%	3.56	3.56	2.67	0.89
2	Contingency	% total cost		3%	3.56	3.56	2.67	0.89
Grand Total =					155.92	155.92	116.87	39.06

 Sub-Assistant Engineer
 HABRA MUNICIPALITY

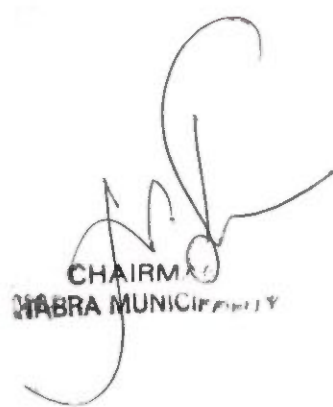

 CHAIRMAN
 HABRA MUNICIPALITY

Estimate for Construction of 50 beded four storied Shelter for urban homeless at Habra under

NULM

(Based on PWD SoR 2014)

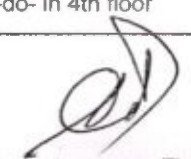
Sl. No.	Description of item	Quantity	Unit	Rate/unit Rs.	Amount Rs.
1 P-1,1-2	Earth work in excavation of foundation trenches or drains, in all sorts of soil (including mixed soil but excluding laterite or sandstone) including removing, spreading or stacking the spoils within a lead of 75 m. as directed. The item includes necessary trimming the sides of trenches, levelling, dressing and ramming the bottom, bailing out water as required complete.				
	(a) Depth of excavation not exceeding 1,500 mm.	170	%Cum	12,047.00	20,479.90
2 P-1,1-3	Earth work in filling in foundation trenches or plinth with good earth, in layers not exceeding 150 mm. including watering and ramming etc. layer by layer complete. (Payment to be made on the basis of measurement of finished quantity of work)				
	(a) With earth obtained from excavation of foundation.	34	%Cum	7,831.00	2,662.54
3 P-2,1-4	(A) Filling in foundation or plinth by silver sand in layers not exceeding 150 mm as directed and consolidating the same by thorough saturation with water, ramming complete including the cost of supply of sand. (payment to be made on measurement of finished quantity)	80	%Cum	98,524.00	78,819.20
4 P-11,1-1	Supplying and laying Polythene Sheet (150gm / sq.m.) over damp proof course or below flooring or roof terracing or in foundation or in foundation trenches.	300	Sqm	25.00	7,500.00
5 P-24, 10	(I) Cement concrete with graded stone ballast (40 mm size excluding shuttering) In ground floor				
	(A) [Pakur Variety]				
	(a) 1:3:6 proportion	40	Cu.M	5,823.00	232,920.00
6 P-26, 12	Hire and labour charges for shuttering with centring and necessary staging upto 4 m. using approved stout props and thick hard wood planks of approved thickness with required bracing for concrete slabs, beams, columns, lintels curved or straight including fitting, fixing and striking out after completion of works. (upto roof of ground floor).				
	(a) 25 mm. to 30 mm. thick wooden shuttering as per decision & direction of Engineer-in-charge. In Ground Floor	500	Sqm	360.00	180,000.00
	(b) -do- in 1st floor	388	Sqm	378.00	146,664.00
	(c) -do- in 2nd floor	388	Sqm	396.00	153,648.00
	(d) -do- in 3rd floor	388	Sqm	414.00	160,632.00
	(e) -do- in 4th floor	70	Sqm	432.00	30,240.00

Sub-Assistant Engineer
HABRA MUNICIPALITY

CHAIRMAN
HABRA MUNICIPALITY

Sl. No.	Description of item	Quantity	Unit	Rate/unit Rs.	Amount Rs.
7 P-14, I- 7 & P- 25, I- 11	Ordinary Cement concrete (mix 1:1.5:3) with graded stone chips(20 mm.nominal size) excluding shuttering and reinforcement, if any. Pakur / Chandil Variety				
	a) in ground floor.	96	Cum	6,979.37	670,019.52
	(b) -do- in 1st floor	48	Cum	7,075.37	339,617.76
	(c) -do- in 2nd floor	48	Cum	7,171.37	344,225.76
	(d) -do- in 3rd floor	48	Cum	7,267.37	348,833.76
	(e) -do- in 4th floor	7	Cum	7,363.37	51,543.59
8 P-27, I- 15	Reinforcement for reinforced concrete work in all sorts of structures including distribution bars, stirrups,binders etc. including supply of rods, initial straightening and removal of loose rust (if necessary), cutting to requisite length, hooking and bending to correct shape,placing in proper position and binding with 16 gauge black annealed wire at every inter-section, complete as per drawing and direction.				
	(a) For works in foundation, basement and upto roof of ground floor / upto 4m.				
	(i) Tor steel	11.3	MT	68,508.00	774,140.40
	(b) -do- in 1st floor	5.7	MT	68,988.00	393,231.60
	(c) -do- in 2nd floor	5.7	MT	69,468.00	395,967.60
	(d) -do- in 3rd floor	5.7	MT	69,948.00	398,703.60
	(e) -do- in 4th floor	1.09	MT	70,428.00	76,766.52
9 P-29, I- 22 & P-30, I- 27	Brick work with 1st class bricks in cement mortar (1:6)				
	(a) In foundation and plinth	16.5	Cu.M.	5,719.00	94,363.50
	(b) In superstructure, ground floor	50	Cu.M.	5,943.00	297,150.00
	(c) In 1st floor	50	Cu.M.	6,055.00	302,750.00
	(d) In 2nd floor	50	Cu.M.	6,167.00	308,350.00
	(e) In 3rd floor	50	Cu.M.	6,279.00	313,950.00
	(f) In 4th floor	10	Cu.M.	6,391.00	63,910.00
10 P-31, I- 29 & P-33, I- 42	125 mm. thick brick work with 1st class bricks in cement mortar (1:4)				
	(a) In ground floor.	100	Sq.M.	783.00	78,300.00
	(b) In 1st floor	140	Sq.M.	795.00	111,300.00
	(c) In 2nd floor	140	Sq.M.	807.00	112,980.00
	(d) In 3rd floor	200	Sq.M.	819.00	163,800.00

 Sub-Assistant Engineer
 HABRA MUNICIPALITY

 CHAIRMAN
 HABRA MUNICIPALITY

Sl. No.	Description of item	Quantity	Unit	Rate/unit Rs.	Amount Rs.
11 P-40, I 3	Artificial stone in floor, dado, staircase etc with cement concrete (1:2:4) with stone chips, laid in panels as directed with topping made with ordinary or white cement (as necessary) and marble dust in proportion (1:2) including smooth finishing and rounding off corners including raking out joints or roughening of concrete surface and application of cement slurry before flooring works using cement @ 1.75 kg/sq.m all complete including all materials and labour.				
	3 mm. thick topping (High polishing grinding on this item is not permitted with ordinary cement). Using grey cement. 20 mm. thick				
	(i) In Ground floor	175	Sq. M	265.00	46,375.00
	(ii) In 1st floor	170	Sq. M	268.98	45,726.60
	(iii) In 2nd floor	170	Sq. M	272.96	46,403.20
	(iii) In 3rd floor	170	Sq. M	276.94	47,079.80
12 P-76, I 10	(a) M.S. or W.I. Ornamental grill of approved design joints continuously welded with M.S, W.I. Flats and bars of windows, railing etc. fitted and fixed with necessary screws and lugs in ground floor.				
	(Add extra @ 1% for each addl. floor upto 4th floor and @ 1.25% for each addl. floor above 4th floor)				
	(i) Grill weighing above 10 Kg./sq.mtr and up to 16 Kg./sq. mtr.				
	(i) Gr. Floor	8	Qntl	9,051.00	72,408.00
	(ii) 1st Floor	8	Qntl	9,141.51	73,132.08
	(iii) 2nd Floor	8	Qntl	9,232.02	73,856.16
	(iv) 3rd Floor	8	Qntl	9,322.53	74,580.24
13 P-77, I 15	Collapsible gate with 40mm x 40mm x 6mm Tee as top and bottom guide rail, 20mm x 10mm x 2mm vertical channels 100mm apart in fully stretched position 20mm x 5mm M.S. flats as collapsible bracings properly rivetted and washered including 38mm steel rollers including locking arrangements, fitted and fixed in position with lugs set in cement concrete and including cutting necessary holes, chasing etc. in walls, floors etc. and making good damages complete.				
	(Add extra @ 1% for each addl. floor upto 4th floor and @ 1.25% for each addl. floor above 4th floor)				
	(a) In ground floor.	15	Sq.m.	4,016.00	60,240.00
	(b) In 1st floor	15	Sq.m.	4,056.16	60,842.40
	(c) In 2nd floor	15	Sq.m.	4,096.32	61,444.80
	(d) In 3rd floor	15	Sq.m.	4,136.48	62,047.20
	(e) In 4th floor	5	Sq.m.	4,176.64	20,883.20



 Sub Assistant Engineer
 HABRA MUNICIPALITY

 CHAIRMAN
 HABRA MUNICIPALITY

Sl. No.	Description of item	Quantity	Unit	Rate/unit Rs.	Amount Rs.
14 P-81, I 33	Supplying, fitting and fixing windows and ventilators with or without integrated grills conforming to IS 1038-1975 and manufactured from rolled steel sections conforming to IS 7452-1974 with non-friction projecting type, box type hinges, glazing clips, lugs locking bracket, handle plate etc, including hoisting in position, straightening if required, fixing lugs in cement concrete (1:2:4) with stone chips 20 mm down cutting holes and mending good damages to match with existing surface complete in all respect excluding glazing.				
	Flash butt welded windows and ventilators (No shop priming will be allowed to facilitate inspection of workmanship) Without integrated grills.				
	(b) Openable steel windows as per IS sizes with side hung shutters and horizontal glazing bars with/without fixed type ventilators. [The extra rate admissible for the openable portion only]				
	(a) In ground floor.	20	Sq. M.	2,031.00	40,620.00
	(b) In 1st floor	20	Sq. M.	2,055.37	41,107.40
	(c) In 2nd floor	20	Sq. M.	2,079.74	41,594.80
	(d) In 3rd floor	20	Sq. M.	2,104.11	42,082.20
	(c)(iv) Two point nose steel handle including fitting and fixing	160	Each	41.00	6,560.00
	(vi) Steel peg stay 300 mm long including fitting and fixing	160	Each	29.00	4,640.00
	(viii) MS integrated grill as per approved design integrated with steel window or ventilator, joints continuously welded with M.S. flat and brass				
	(a) In ground floor.	310	kg.	85.00	26,350.00
	(b) In 1st floor	310	kg.	86.02	26,666.20
	(c) In 2nd floor	310	kg.	87.04	26,982.40
	(d) In 3rd floor	310	kg.	88.06	27,298.60
15 P-85, I 1	Wood work in door and window frame fitted and fixed in position complete including a protective coat of painting at the contact surface of the frame excluding cost of concrete, Iron Butt Hinges and M.S clamps. (The quantum should be corrected upto three decimals).				
	(d) Sal : Local.	1.070	Cu.M	89,279.00	95,528.53
16 P-90, I 18	Supplying, fitting and fixing M.S. clamps for door and window frame made of flat bent bar, end bifurcated with necessary screws etc. by cement concrete(1:2:4) as per direction. (Cost of concrete will be paid separately)				
	(c) 40mm X 6mm, 125mm Length	100	Each	22.00	2,200.00
17 P-91, I 20	Iron butt hinges of approved quality fitted and fixed with steel screws, with ISI mark.				
	(v) 75mm. X 60mm. X 3.15mm.	140	Each	54.00	7,560.00

 Sub-Assistant Engineer
 HABRA MUNICIPALITY

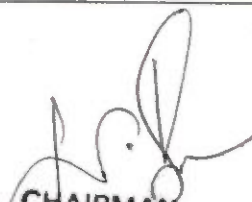
16

 CHAIRMAN
 HABRA MUNICIPALITY

Sl. No.	Description of item	Quantity	Unit	Rate/unit Rs.	Amount Rs.
18 P-93, I-25	Iron socket bolt of approved quality fitted and fixed complete.				
	(c) 150mm long x 10mm dia bolt.	86	Each	71.00	6,106.00
19 P-93, I-27	i) Iron hasp bolt of approved quality fitted and fixed complete (oxidised) with 16mm dia rod with centre bolt and round fitting.				
	(c) 300mm long.	43	Each	193.00	8,299.00
20 P-100, I-65(ii)	Anodised aluminium D-Type handle of approved quality manufactured from extruded erection conforming to I.S. specification (I.S. 230/72) fitted and fixed a) With continuous plate base (Hexagonal/Rounded) ii) 100 mm grip x 10 mm dia rod	43	Each	79.00	3,397.00
21 P-119, I-101 & P-129, I-128	Supplying solid flush type doors of commercial quality, the timber frame consisting of top and bottom rails and side styles of well seasoned timber 65mm wide each and the entire frame fitted with 37.5mm wide battens places both ways in order to make the door of solid core and internal lipping with Garjan or similar wood veneers using phenol formaldehyde as glue etc. complete, including fitting, fixing shutters in position but excluding the cost of hinges and other fittings in ground floor.				
	(b) 32 mm thick shutters (single leaf)				
	(a) In ground floor.	9.5	Sq. M.	2,785.00	26,457.50
	(b) In 1st floor	9.5	Sq. M.	2,800.00	26,600.00
	(c) In 2nd floor	9.5	Sq. M.	2,815.00	26,742.50
	(d) In 3rd floor	9.5	Sq. M.	2,830.00	26,885.00
22 P-132, I-144	Supplying, fitting and fixing fibre reinforced polymer (FRP) Composite door frame as per approved section with glass fibre reinforced plastic moulded skins and a special sandwich core, so as to impart monolithic composite structure as per approved technology of Department of Science and Technology (DST) to satisfy IS: 4020 door testing performance criteria.				
	(ii) 66mm x 90mm	140	Mtr.	586.00	82,040.00

 Sub-Assistant Engineer
 HABRA MUNICIPALITY

 CHAIRMAN
 HABRA MUNICIPALITY

Sl. No.	Description of item	Quantity	Unit	Rate/unit Rs.	Amount Rs.
23 P-133, I-145 & P- 129, I- 128	Supplying, Fitting & Fixing 30 mm thick Factory made solid Panel PVC Door Shutter consisting of outer frame made out of M.S. tubes of 19 gauge thickness and size 19 mmx19 mm for styles, top and bottom rails, M.S. frame shall have cost of steel primers of approved make and manufacture, M.S. frame covered with 5 mm th. heat moulded PVC "C" channel of size 30 mm th, 70 mm width out of which 50 mm shall be flat and 20 mm shall be tapered in 45 degree angle on either sides forming styles; and 5 mm th. 95 mm wide PVC sheet out of which 75 mm shall be flat and 20 mm tapered in 45 degree on the inner side to form top & bottom rail and 115 mm wide PVC sheet out of which 75mm shall be flat and 20 mm shall be tapered on both sides to form lock rail. Top, bottom and lock rails shall be provided either side of the panel with 10 mm (5 mmx2) th., 20 mm wide cross PVC sheet as gap insert for top rail and bottom rail. Paneling of 5 mm th. both side PVC sheet to be fitted in the M.S. frame welded/sealed to the styles & rails with 7 mm (5 mm+2 mm) th.x15 mm wide PVC sheet beading on inner side and joined together with solvent cement adhesive. An additional 5 mm th. PVC strip of 20 mm which is to be stuck on the interior side of the "C" channel using PVC solvent adhesive etc. complete excluding all necessary hardwares as per direction of Engineer-in-Charge.				
	(a) In ground floor.	11.5	Sq.m	2,277.00	26,185.50
	(b) In 1st floor	11.5	Sq.m	2,292.00	26,358.00
	(c) In 2nd floor	11.5	Sq.m	2,307.00	26,530.50
	(d) In 3rd floor	11.5	Sq.m	2,322.00	26,703.00
24 P-151, I-2 & P-152, I-5	Plaster (to wall, floor, ceiling etc.) with sand and cement mortar including rounding off or chamfering corners as directed and raking out joints including throating, nosing and drip course, scaffolding/staging where necessary .[Excluding cost of chipping over concrete surface] A) In Ground floor				

 Sub-Assistant Engineer
 HABRA MUNICIPALITY

 CHAIRMAN
 HABRA MUNICIPALITY

Sl. No.	Description of item	Quantity	Unit	Rate/unit Rs.	Amount Rs.
	(i) With 1:6 cement mortar				
	(b) 20 mm thick plaster	600	Sq.M	181.00	108,600.00
	(c) 15 mm thick plaster	200	Sq.M	156.00	31,200.00
	(ii) With 1:4 cement mortar				
	(c) 10 mm thick plaster	189	Sq.M	140.00	26,460.00
	B) In 1st floor				
	(i) With 1:6 cement mortar				
	(b) 20 mm thick plaster	600	Sq.M	185.00	111,000.00
	(c) 15 mm thick plaster	162	Sq.M	160.00	25,920.00
	(ii) With 1:4 cement mortar				
	(c) 10 mm thick plaster	189	Sq.M	144.00	27,216.00
	C) In 2nd floor				
	(i) With 1:6 cement mortar				
	(b) 20 mm thick plaster	600	Sq.M	189.00	113,400.00
	(c) 15 mm thick plaster	162	Sq.M	164.00	26,568.00
	(ii) With 1:4 cement mortar				
	(c) 10 mm thick plaster	189	Sq.M	148.00	27,972.00
	C) In 3rd floor				
	(i) With 1:6 cement mortar				
	(b) 20 mm thick plaster	600	Sq.M	193.00	115,800.00
	(c) 15 mm thick plaster	162	Sq.M	168.00	27,216.00
	(ii) With 1:4 cement mortar				
	(c) 10 mm thick plaster	189	Sq.M	152.00	28,728.00
	C) In 4th floor				
	(i) With 1:6 cement mortar				
	(b) 20 mm thick plaster	50	Sq.M	197.00	9,850.00
	(c) 15 mm thick plaster	140	Sq.M	172.00	24,080.00
	(ii) With 1:4 cement mortar				
	(c) 10 mm thick plaster	25	Sq.M	156.00	3,900.00
25	Neat cement punning about 1.5 mm. thick in wall, dado, window, sills, floor, drain etc. NOTE : Cement 0.152 cu.m. per 100 sq.m.	120	Sq.M	38.00	4,560.00
P-152, I-8					
26	White washing including cleaning and smoothening surface thoroughly.				
P-155, I-3					
	All floors :				
	(c) Three coats (on new works only).	740	%Sq.M	2,081.00	15,399.40

 Sub-Assistant Engineer
 HABRA MUNICIPALITY

 CHAIRMAN
 HABRA MUNICIPALITY

Sl. No.	Description of item	Quantity	Unit	Rate/unit Rs.	Amount Rs.
27 P-155, I-5	Colour washing with any shade with Stainers, as required including cleaning and smoothening surface thoroughly :				
	(i) Internal surface (All floors)				
	(b) Two coats (on new works only).				
	(i) Other than yellow, pink.	2420	%Sq.M	2,139.00	51,763.80
28 P-158, I-16 & P-159, I-20	Applying decorative cement based paint of approved quality after preparing the surface including scraping the same thoroughly (plastered or concrete surface) as per manufacturer's specification. (iii) Two coats.				
	(a) In ground floor.	200	Sq.M	53.00	10,600.00
	(b) In 1st floor	162	Sq.M	53.72	8,702.64
	(c) In 2nd floor	162	Sq.M	54.44	8,819.28
	(d) In 3rd floor	162	Sq.M	55.16	8,935.92
	(e) In 4th floor	100	Sq.M	55.88	5,588.00
29 P-162, I-7	(A) Priming one coat on timber surface with synthetic oil bound primer of approved quality including smoothening surfaces by sand papering etc.	328	Sq.M	41.00	13,448.00
	(B) Priming one coat on steel or other metal surface with synthetic oil bound primer of approved quality including smoothening surfaces by sand papering etc.	270	Sq.M	31.00	8,370.00
30 P-162, I-8	(A) Painting with best quality synthetic enamel paint of approved make and brand including smoothening surface by sand papering etc. including using of approved putty etc. on the surface, if necessary :				
	(a) On timber or plastered surface :				
	With super gloss (hi-gloss) -				
	(iv) Two coats (with any shade except white)	328	Sq.M	89.00	29,192.00
	On Steel /metal surface				
	With other than hi-gloss of approved quality-				
	(iv) Two coats (with any shade except white)	270	Sq.M	77.00	20,790.00
31 P-166, I-1	Supplying best Indian sheet glass panes set in putty and fitted and fixed with nails and putty complete. (In all floors for internal wall & upto 6 m height for external wall)				
	(ii) 4 mm thick	80	Sq.M	615.00	49,200.00

 Sub-Assistant Engineer
 HABRA MUNICIPALITY

 CHAIRMAN
 HABRA MUNICIPALITY

Sl. No.	Description of item	Quantity	Unit	Rate/unit Rs.	Amount Rs.
32 P-173, I-21	Supplying, fitting & fixing UPVC pipes A- Type and fittings conforming to IS:13592-1992 with all necessary clamps nails, including making holes in walls, floor etc. cutting trenches in any soil through masonry concrete structures etc if necessary and mending good damages including joining with jointing materials (Spun Yarn, Valamoid/Bitumen/M-Seal etc) complete.				
	A) UPVC Pipes:				
	(i)110 mm. Dia.	101	Metre	291.00	29,391.00
	B) UPVC fitting : 110 mm dia				
	(i) Plain Tee	6	Each	200.00	1,200.00
	(ii) Bend 87.5 degree	6	Each	162.00	972.00
	(iii) Shoe	6	Each	128.00	768.00
33 P-307 I- 17.01	Mobilisation Charges of all tools & Plants along with accessories, material, labour, supervision etc. at site of work required in connection with boring and testing work, including setting up boring rigs and shifting to different Bore-hole points etc. and also including withdrawal of same from the site after completion of work, complete as per direction of Engineer-in-Charge. a) Preliminary Investigation.	1	Item	8000.00	8,000.00
34 P-307 I- 17.02	Carriage of all Disturbed & Undisturbed Samples from site of work to the Divisional office or elsewhere including loading and unloading as per direction of Engineer-in-Charge. Detailed Investigation.	2	Item	1600.00	3,200.00
34 P-307 I- 17.03	Labour for boring by sinking and finally withdrawing 50mm to 100mm dia. (internal) pipe by a standard method to any depth below ground level / bed level in all types of soil like clay, silt, sand, stiff clay, mixed soils etc. except rocks, including collection of disturbed soil samples and including preparation and submission of bore-log as per standard proforma and also including hire charges of tool and plants complete as per direction of Engineer-in-Charge. Depth 0m to 30 m	30	Mtr	150.00	4,500.00
	Civil work Total =				9,091,292.10
	Add for Sanitary & Plumbing 10%				909,129.21
	Add for Electrification with fittings 10%				909,129.21
	Total =				10,909,551.00

Rupees One Crore Nine Lakh Nine Thousand Five Hundred Fifty One Only

Sub-Assistant Engineer
HABRA MUNICIPALITY



CHAIRMAN
HABRA MUNICIPALITY

Cost Estimate for Furniture & Utensils Requirement of Shelter for Urban Homeless : 4 storied for 50 person

Sl.	Item	Quantity	Unit	Rate (LS) Rs.	Amount Rs.
1	Steel Cot (Single)	50	Nos	5000.00	250000.00
2	Bed side small steel cabinet	50	Nos	2000.00	100000.00
3	Wooden Dinning Table (Four seater) made Sishu or similar wood	0	Nos	5600.00	0.00
4	Wooden Dinning Chair made Sishu or similar wood	0	Nos	2500.00	0.00
5	Cup Board Door cover with locking arrangements made of Sishu or similar wood	25	Nos	7500.00	187500.00
6	Mattress, Pillow, Bed cover, Rag, Mosquito net etc.	50	Set	2500.00	125000.00
7	Arrangement of cooking gas connection including special type oven	2	Nos	10000.00	20000.00
8	Water Purifier	2	Nos	10000.00	20000.00
9	Almirah	4	Nos	15000.00	60000.00
10	Office Table	2	Nos	4000.00	8000.00
11	Kitchen Cabinet			L.S.	50000.00
12	Utensils for cooking & food			L.S.	50000.00
				Total	870500.00

Rupees Eight Lakh Seventy Thousand Five Hundred Only

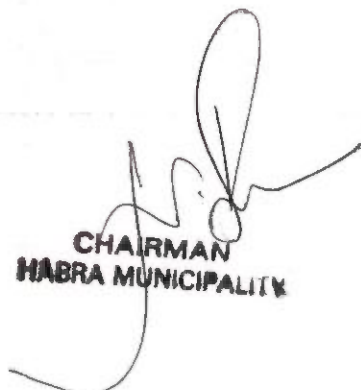
Sub-Assistant Engineer
HABRA MUNICIPALITY

CHAIRMAN
HABRA MUNICIPALITY

**A PROPOSED SITE PLAN FOR CONSTRUCTION OF NIGHT SHELTER ROOM AT SARADA BHAVAN
GROUND OF L.O.P. NO.-439, MOUZA- ASSRAFABAD, J.L. NO- 84, P.O. - BANIPUR, WORD NO-22,
UNDER HABRA MUNICIPALITY**

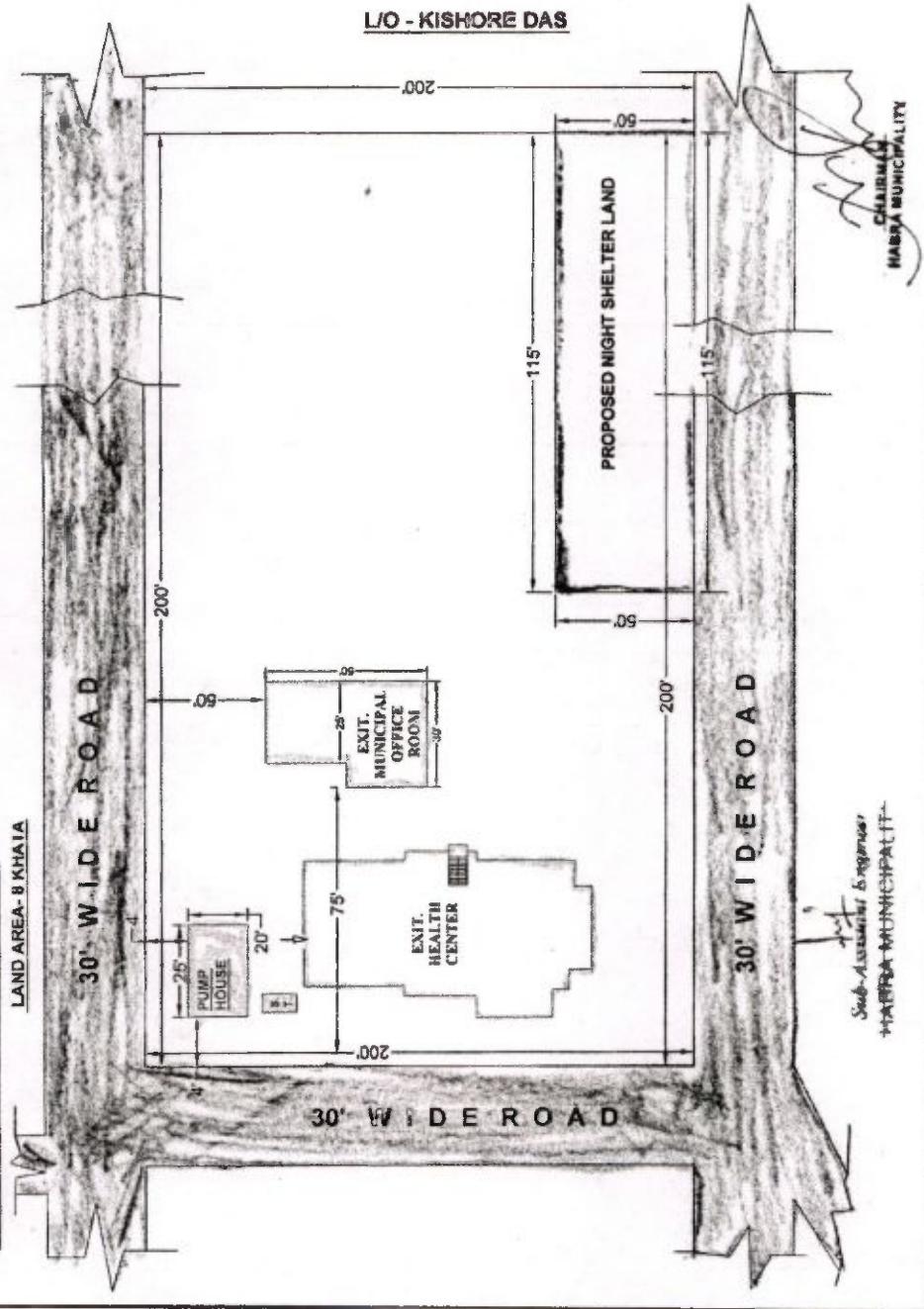

PROPOSED SITE DETAILS

Sub-Assistant Engineer
HABRA MUNICIPALITY

CHAIRMAN
HABRA MUNICIPALITY

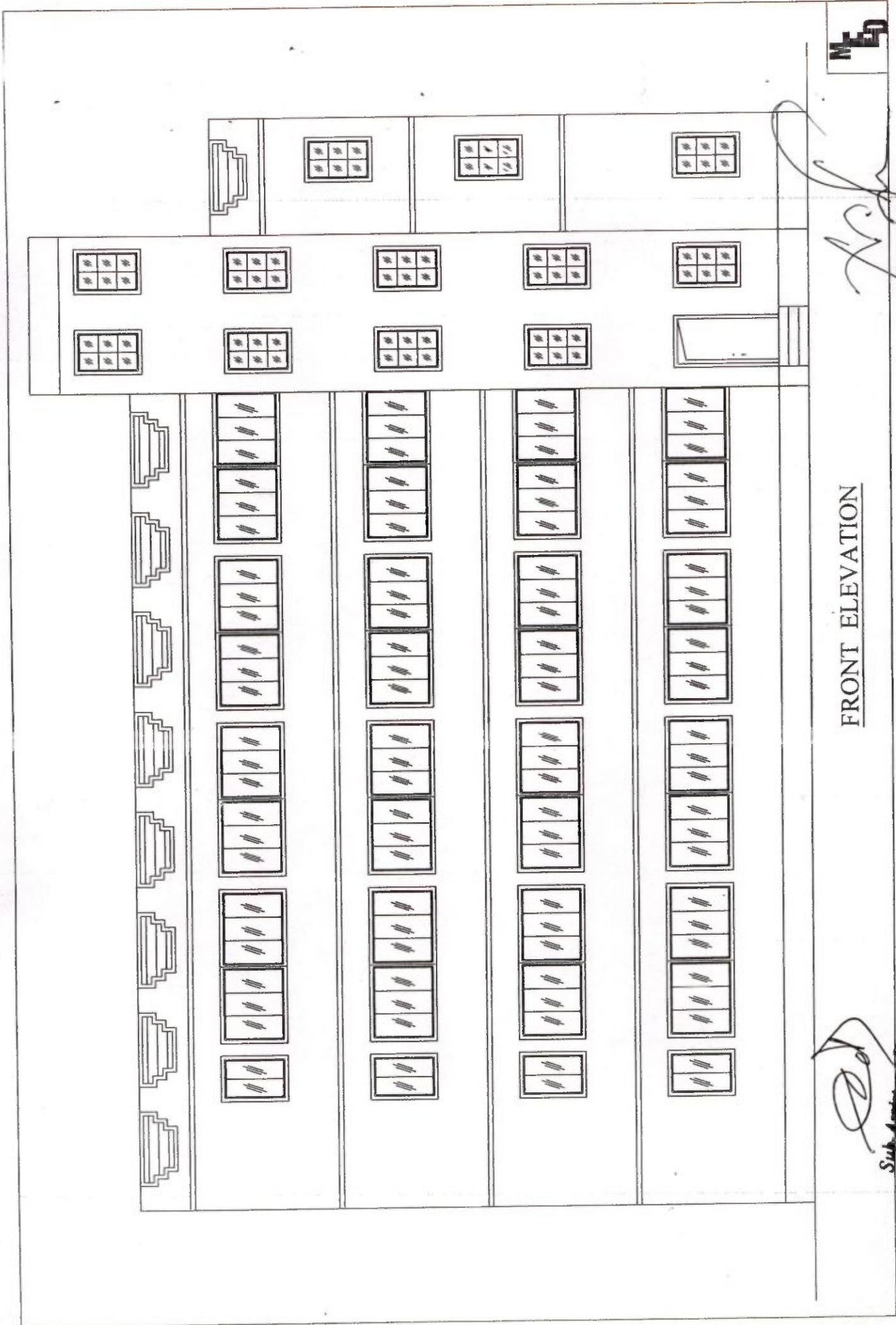

FRONT ELEVATION

[Signature]
Sub-Assistant Engineer

HABRA MUNICIPALITY

[Signature]
CHAIRMAN

HABRA MUNICIPALITY

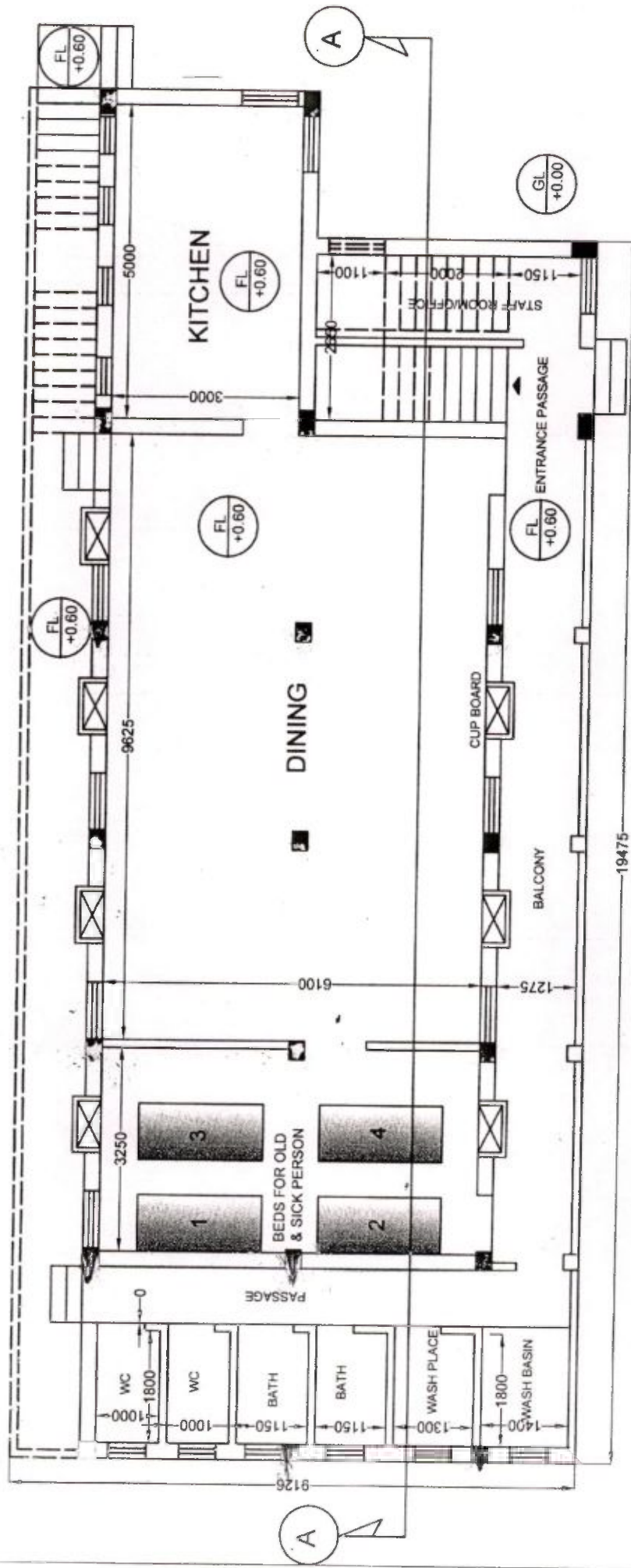

GROUND FLOOR PLAN FOR FOUR STORIED NIGHT SHELTER FOR 50 PERSON

AREA STATEMENT	
COVERED AREA	184.16 SQM OR 1982 SFT
DORMITORY FLOOR AREA	19.82 SQM OR 213 SFT

[Signature]
CHAIRMAN
HABRA MUNICIPALITY

[Signature]
Sub-Assistant Engineer
HABRA MUNICIPALITY

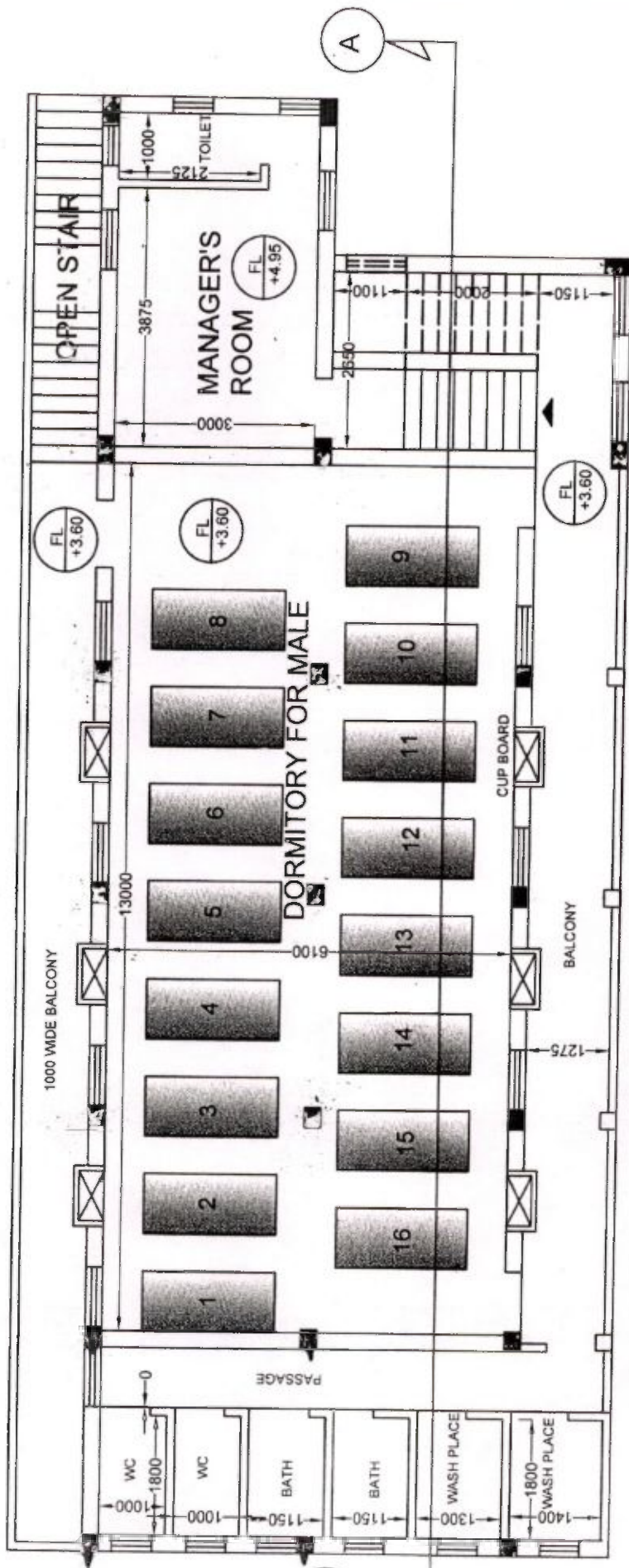

FIRST FLOOR PLAN FOR FOUR STORED NIGHT SHELTER FOR 50 PERSON

AREA STATEMENT	
DORMITORY FLOOR AREA	79.30 SQM OR 854 SFT

[Signature]
 Sub-Assistant Engineer
 HABRA MUNICIPALITY

[Signature]
 CHAIRMAN
 HABRA MUNICIPALITY

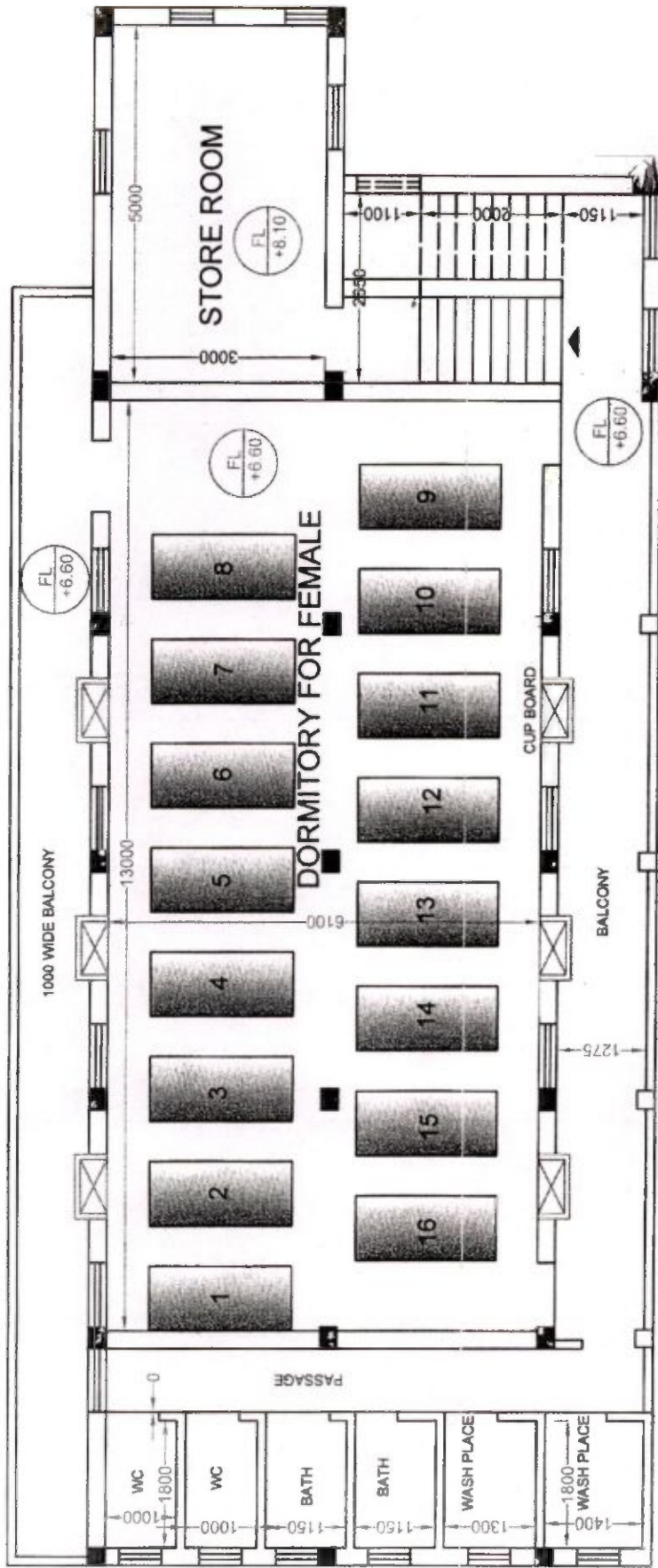

SECOND FLOOR PLAN FOR FOUR STORIED NIGHT SHELTER FOR 50 PERSON

AREA STATEMENT	
DORMITORY FLOOR AREA	79.30 SQM OR 854 SFT

[Signature]
 Sub-Assistant Engineer
 HABRA MUNICIPALITY

[Signature]
 CHAIRMAN
 HABRA MUNICIPALITY

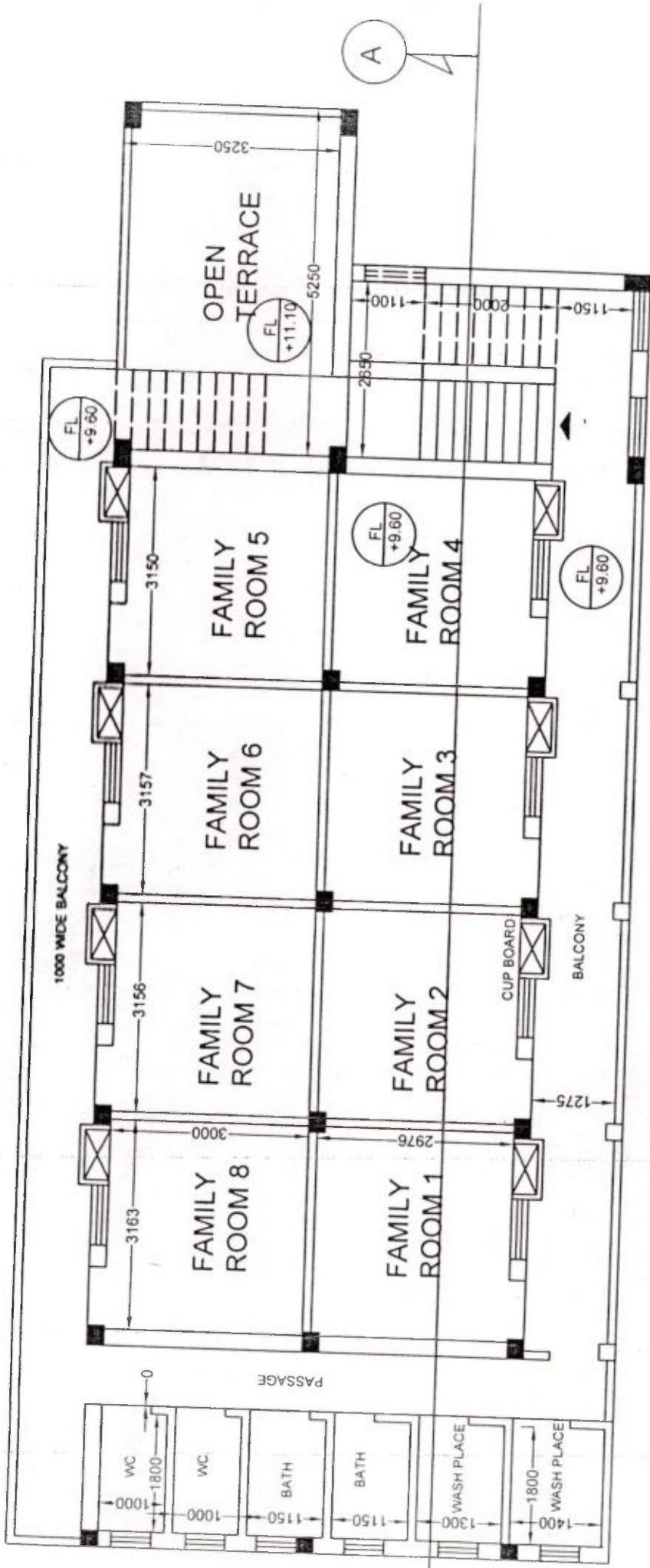

THIRD FLOOR PLAN FOR FOUR STORIED NIGHT SHELTER FOR 50 PERSON

AREA STATEMENT	
DORMITORY FLOOR AREA	75.45 SQM OR 812 SFT



[Signature]
CHAIRMAN

[Signature]
Sub-Assistant Engineer
HABRA MUNICIPALITY

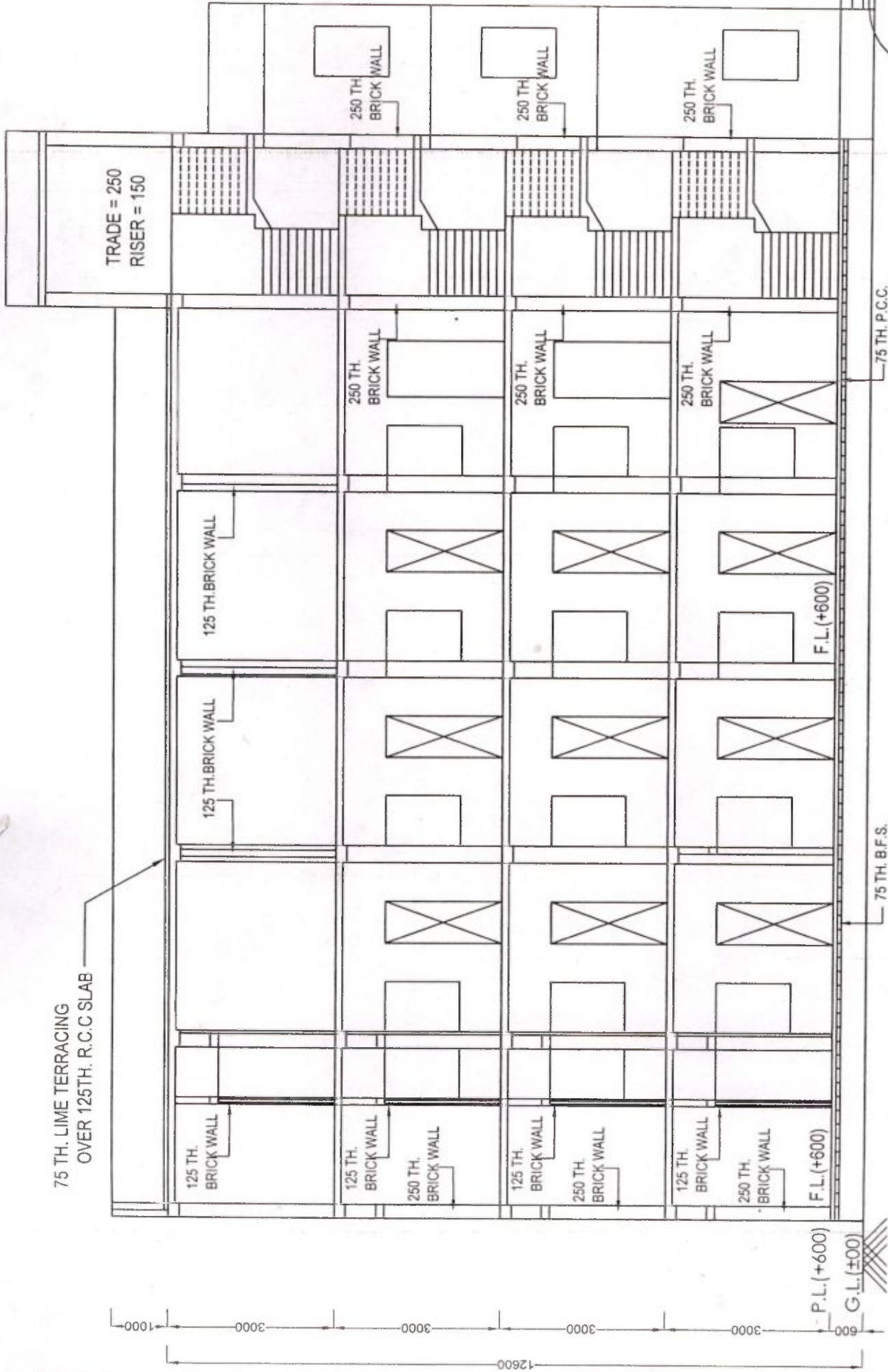

SECTION AT A-A

[Handwritten Signature]

Sub-Assistant Engineer
HABRA MUNICIPALITY

[Handwritten Signature]

CHAIRMAN
HABRA MUNICIPALITY

O & M PLAN for each shelter

The mode of operation and maintenance work will be maintained by the Habra Municipality.

O & M cost per Year :

1 Annual Maintenance cost of Shelter					
i)	Electricity charges	12	Months	5000.00	60000.00
ii)	Maintenance of Plumbing & Electrical work	12	Months	500.00	6000.00
2 Annual Servicing Cost					
i)	Sweeping charges	12	Months	3000.00	36000.00
ii)	Replenishment of bedding	10%	of capital cost		12500.00
iii)	Replenishment of Kitchen equipment	10%	of capital cost		5000.00
3	Cost of providing free food for 10% of inmates who are old/infirm and cannot pay (50x365x10%)	1825	Days	100	182500.00
4 Staff Salary					
i)	Manager (full time)	12	Months	10000.00	120000.00
	Caregivers: 3 nos for 3 shifts of 8 hrs (including at least one female)	36	Months	5000.00	180000.00
				Total	602000.00
Rupees Six Lakh Two Thousand Only					

There is a provision of Rs. 6.00 Lakh per annum for the shelter towards the expenditure of annual O&M for 5 years, the expenditure beyond 6.00 lakh will be arranged by the ULB.

Sub-Assistant Engineer
HABRA MUNICIPALITY

30

CHAIRMAN
HABRA MUNICIPALITY

USER FEES :

User fees will be levied with the objective of improving participation of the residents in operations of the shelter and will be modestly priced. The fund so collected will be utilized for maintenance of the facilities. The following will determine the norms and application of user fees by any implementing authority:

a) Nominal charges proposed to be collected depending on the income levels of the urban homeless at rates ranging from 1/10 to 1/20 of their income. For those with no payment capacities, total exemption will be granted.

b) Meals provided at the shelter will be fully subsidized for old, infirm, disabled women and men and all children. For other shelter residents, meals may be provided at subsidized costs.

c) All residents will be encouraged to offer voluntary services for maintenance of shelter homes including mess facilities, cleanliness, etc. on rotation basis (e.g. half day service per person /week). These norms are to be evolved by the shelter manager together with the shelter management committee.

MONITORING AND EVALUATION

Under NULM, an Executive Committee under the chairpersonship of the Municipal Commissioner will be constituted to manage the affairs of NULM. This EC at the city level will be responsible for review and supervision of the working of shelters with the participation of community representatives, civil society organizations, line departments and elected representatives, etc.

O & M AFTER FIVE YEARS:

Efforts will be taken for upliftment of economic condition of the shelter habitants by development of livelihood and vocational skills. Linkage with different employment generation scheme will be made in priority basis by the Executive Committee with the help of ULB. And it is expected that they will be able to contribute towards O & M costs substantially and for old/ infirm inmates ULB will take up the responsibility.

PUBLICITY OF INFORMATION

In order to ensure that the information about availability of shelters for urban homeless reaches the ultimate beneficiaries, i.e. the targeted population, adequate publicity measures will be taken by the Habra Municipality on regular basis.

Sub-Assistant Engineer
HABRA MUNICIPALITY

31

CHAIRMAN
HABRA MUNICIPALITY

FUND FLOW PATTERN

Rupees in lakhs

SL. NO	DPR COST	O & M YEAR												TOTAL								
		IMPLEMENTATION YEAR						O & M YEAR														
		1st Year			2nd Year			3rd Year			4th Year				5th Year			6th Year				
		GOI	GOWB	Total	GOI	GO WB	Total	GOI	GO WB	Total	GOI	GO WB	Total	GOI	GO WB	Total	GOI	GO WB	Total			
1	155.92	94.37	31.46	125.82	4.50	1.52	6.02	4.50	1.52	6.02	4.50	1.52	6.02	4.50	1.52	6.02	4.50	1.52	6.02	155.92		
		O & M YEAR																				
		4th Year			5th Year			6th Year			6th Year			6th Year			6th Year					
		GOI	GO WB	Total	GOI	GO WB	Total	GOI	GO WB	Total	GOI	GO WB	Total	GOI	GO WB	Total	GOI	GO WB	Total	GOI	GO WB	Total
		4.50	1.52	6.02	4.50	1.52	6.02	4.50	1.52	6.02	4.50	1.52	6.02	4.50	1.52	6.02	4.50	1.52	6.02	4.50	1.52	6.02

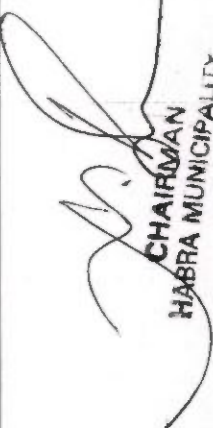

Sub-Assistant Engineer

HABRA MUNICIPALITY











CHAIRMAN
HABRA MUNICIPALITY

Implementation Schedule

Sl. No.	Activity	Months											
		1	2	3	4	5	6	7	8	9	10	11	12
1	Invitation & Finalization of Tenders	■											
2	Building												
2.1	Upto Plinth Level	■											
2.2	Upto Ground floor Roof	■											
2.3	Upto First floor Roof	■											
2.4	Upto Second floor Roof	■											
2.5	Upto Third floor Roof	■											
2.6	Star Room Roof etc.	■											
2.7	Plastering, flooring, Door Window etc.	■											
2.8	Sanitary & Plumbing works	■											
2.9	Internal Electrification	■											
2.10	Service Connections	■											
2.11	Colour wash & Finishing	■											
3	Procurement of Furniture and Utensils	■											
4	Establishment of Fire Fighting arrangement	■											
5	Inauguration	■											







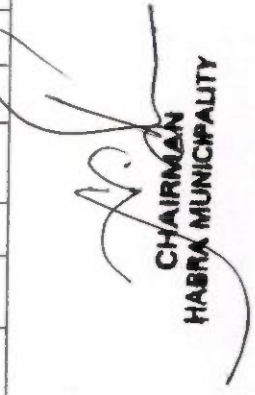

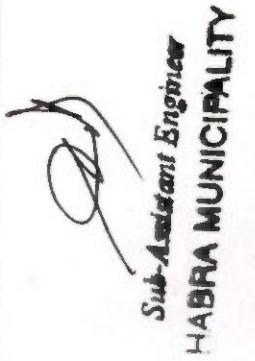



 Sub-Assistant Engineer
 HABRA MUNICIPALITY



 CHAIRMAN
 HABRA MUNICIPALITY

Sl. No.	Form No.	Name of the ULB	Ward no.	Name of street / location	Nearest landmark	Full name of respondent	Father's/Husband's name in full	Whether willing to avail Govt. arranged shelter?	Present living location	Whether living in slum location	Photo No.	Full Name	Relation with respondent	Age as on 01/01/14	Sex	Physically challenged	Menially challenged	Whether illiterate	Formal education	Occupation	Monthly Income	Photo
1	1	Habra Municipality	21	Banipur Ina Market	Cotton Centre	Shakti Som Chowdhury	LI. Basial	Y	Same as column H	Y	C1-1	Shakti Som Chowdhury		72 Yrs	M	N	N	N		Beggar	Rs.300/-	
2	2	Habra Municipality	21	Banipur Ina Market	Cotton Centre	Kamala Debnath	LI. Anil	Y	Same as column H	Y	C 1 - 2	Kamala Debnath		71 Yrs	F	N	N	Y	IV	Sebadasi	100/-	
3	3	Habra Municipality	24	Banipur Home	Banipur Habra	Md Abdul Wahab	Ranjana Moliah	Y	Same as column H	Y	C 1 - 3	Md. Abdul Wahab		62 Yrs	M	N	N	Y	III	Van Puller	700/-	
4	4	Habra Municipality	6	Super Market	Habra Bus Stand	Chotika Basopore	Lala Leijpat Basopore	Y	Same as column H	Y	C 1 - 4	Chotika Basopore		38 Yrs	M	N	N	N		Sweeper	1200/-	
5	4	Habra Municipality	7	Super Market	Habra Bus Stand	Bundi Basopore	Chotika Basopore	Y	Same as column H	Y	C 1 - 5	Bundi Basopore	Wife	36 Yrs	M	N	N	N		Sweeper	1200/-	
6	4	Habra Municipality	8	Super Market	Habra Bus Stand	Suni Basopore	Chotika Basopore	Y	Same as column H	Y	C 1 - 6	Suni Basopore	Son	15 Yrs	M	N	N	Y	V	Student	Nil	
7	4	Habra Municipality	9	Super Market	Habra Bus Stand	Bedal Basopore	Chotika Basopore	Y	Same as column H	Y	C 1 - 7	Bedal Basopore	Son	13 Yrs	M	N	N	Y	IV	Student	Nil	
8	4	Habra Municipality	10	Super Market	Habra Bus Stand	Munna Basopore	Chotika Basopore	Y	Same as column H	Y	C 1 - 8	Munna Basopore	Son	11 Yrs	M	N	N	Y	III	Student	Nil	
9	4	Habra Municipality	11	Super Market	Habra Bus Stand	Tiki Basopore	Chotika Basopore	Y	Same as column H	Y	C 1 - 9	Tiki Basopore	Daughter	18 Yrs	F	N	N	N		House Wife	Nil	
10	4	Habra Municipality	12	Super Market	Habra Bus Stand	Payel Basopore	Chotika Basopore	Y	Same as column H	Y	C 1 - 10	Payel Basopore	Daughter	4 Yrs	F	N	N	N			Nil	

CHAIRMAN
HABRA MUNICIPALITY

Sub-Assistant Engineer
HABRA MUNICIPALITY

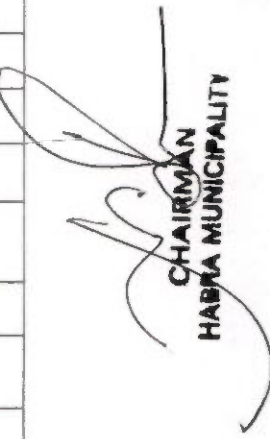
Sr	Form No.	Name of the ULB	Ward no.	Name of street/ location.	Nearest landmark	Full name of respondent	Father's Husband's name in full	Whether willing to avail Govt. arranged shelter?	Present living location	Whether living in slum location	Photo No.	Full Name	Relation with respondent	Age as on 01/01/14	Sex	Physically challenged	Mentally challenged	Wholesaler/ retailer	Formal education	Occupation	Monthly income	Photo
11	4	Habra Municipality	13	Suprer Market	Habra Bus Stand	Suve Basopore	Sutihal	Y	Same as column H	Y	C 1 - 11	Suve Basopore	Grand Son	2 Yrs	M	N	N	N			Nil	
12	5	Habra Municipality	6	Suprer Market	Habra Bus Stand	Pirul Mali	Lt Bidosh Mali	Y	Same as column H	Y	C 1 - 12	Pirul Mali		60 Yrs	F	N	N	N	N	Sweeper	1000/-	
13	5	Habra Municipality	7	Suprer Market	Habra Bus Stand	Mamani Mondal	Lt Bidosh Mali	Y	Same as column H	Y	C 1 - 13	Mamani Mondal	Daughter	38 Y	F	N	N	N	N	Servant	1000/-	
14	5	Habra Municipality	8	Suprer Market	Habra Bus Stand	Sharati Mali	Lt Bidosh Mali	Y	Same as column H	Y	C 1 - 14	Sharati Mali	Daughter	18 Y	F	N	N	Y	Y	Student	Nil	
15	5	Habra Municipality	9	Suprer Market	Habra Bus Stand	Raja Mali	Lt Bidosh Mali	Y	Same as column H	Y	C 1 - 15	Raja Mali	Son	9 Y	M	N	N	Y	II	Student	Nil	
16	5	Habra Municipality	10	Suprer Market	Habra Bus Stand	Hiru Mondal	Manoj	Y	Same as column H	Y	C 1 - 16	Hiru Mondal	Grand son	15 Y	M	N	N	N		Labour	1000/-	
17	5	Habra Municipality	11	Suprer Market	Habra Bus Stand	Parveen Mondal	Manoj	Y	Same as column H	Y	C 1 - 17	Parveen Mondal	Grand Daughter	12 Y	F	N	N	Y	II	Student	Nil	
18	5	Habra Municipality	12	Suprer Market	Habra Bus Stand	Madan Mondal	Manoj	Y	Same as column H	Y	C 1 - 18	Madan Mondal	Grand son	9 Y	M	N	N	N			Nil	
19	5	Habra Municipality	13	Suprer Market	Habra Bus Stand	Moti Mondal	Manoj	Y	Same as column H	Y	C 1 - 19	Moti Mondal	Grand son	2 Y	M	N	N	N			Nil	
20	6	Habra Municipality	6	Suprer Market	Habra Bus Stand	Rintu Som	Dujal Ch. Som	Y	Same as column H	Y	C 1 - 20	Rintu Som		40 Y	M	N	N	Y	N	Labour	1000/-	
21	7	Habra Municipality	2	Hathuba Bus stand	Hathuba High School	Not Respondent			Same as column H	Y	C 1 - 21	Not Respondent		22 Y	M	Y	Y				Nil	

CHAIRMAN
HABRA MUNICIPALITY

Sub-Assistant Engineer
HABRA MUNICIPALITY

হাবড়া পৌরসভা
হাবড়া, উত্তর ২৪-পরগণা

বোর্ড-অব-কাউন্সিলর্স-এর সাধারণ সভা

তারিখ : ২৫-০১-২০১৬ (সোমবার)

সময় : দুপুর ৩-০০ ঘটিকা

স্থান : অধিবেশন কক্ষ (পৌরভবন)

উপস্থিত কাউন্সিলরবৃন্দের নাম :

১। শ্রী নীলিমেশ দাস	- পৌরপ্রধান
২। শ্রীমতি রাখী দাস	- উপ-পৌরপ্রধান
৩। শ্রীমতি তপতী দত্ত	- কাউন্সিলর
৪। শ্রীমতি নন্দা চক্রবর্তী	- "
৫। শ্রী আশীষ কঠ মুখার্জী	- "
৬। শ্রী ঋজিনন্দন বিশ্বাস	- "
৭। শ্রী তারকনাথ দাস	- "
৮। শ্রীমতি সোমা রায়	- "
৯। শ্রীমতী পূর্ণিমা (দাস) সরকার	- "
১০। শ্রীমতি শান্তা ভট্টাচার্য্য	- "
১১। শ্রী গৌতম বিশ্বাস	- "
১২। শ্রী সুজিৎ বিশ্বাস	- "
১৩। শ্রী অশোক কুমার সাহা	- "
১৪। শ্রী কৃষ্ণপদ দাস	- "
১৫। শ্রীমতি রুমা চ্যাটার্জী	- "
১৬। শ্রীমতি গোপা দাস	- "
১৭। শ্রীমতি গাঙ্গী ঘোষ	- "
১৮। শ্রী শ্যামল কুমার দাস	- "
১৯। শ্রী প্রসেনজিৎ দত্ত	- "
২০। শ্রী নারায়ন চন্দ্র সাহা	- "

অধ্যকার সভায় সভাপতিত্ব করেন পৌরপ্রধান শ্রী নীলিমেশ দাস মহাশয়।

Certified True copy

CHAIRMAN
HABRA MUNICIPALITY

সিদ্ধান্ত :

- ১।-----
- ২।-----
- ৩।-----
- ৪।-----

৫। বিবিধ :

ক) হাবড়া পৌর অঞ্চলের আশ্রয়হীনদের রাতে থাকবার জন্য DPR, MED-তে পাঠাবার বিষয়ে পৌরপ্রধানের উপর দায়িত্ব অর্পন করা হল।

আর কোন আলোচ্য বিষয় না থাকায় পৌরপ্রধান সকলকে ধন্যবাদ জানিয়ে অধ্যকার সভার সমাপ্তি ঘোষণা করেন।

হাবড়া
২৫-০১-২০১৬

Certified True copy

**CHAIRMAN
HABRA MUNICIPALITY**

স্বাক্ষর : শ্রী নীলিমেশ দাস
সভাপতি

GOVERNMENT OF WEST BENGAL
OFFICE OF THE DISTRICT MAGISTRATE
REFUGEE RELIEF & REHABILITATION DEPARTMENT
DISTRICT- NORTH 24 PARGANAS, BARASAT

Memo No. 14/RR/BST
W-21019(12)/2/2016

Date: 20.01.2016

To
The Chairman,
Habra Municipality,
North 24 Paraganas.

Sub: Issuances of NOC to use RR land for construction of Night Shelter
at LOP -439, Asrafabad 'B' Scheme.

With reference to the above, the undersigned sends herewith NOC (memo no.
L/16/RC dated 19.01.2016 of the Dy. RR Commissioner, RR Directorate) for construction of
Night Shelter/ Shelter for Urban Homeless at LOP -439, area – 8 (eight) cottah, more or less
of Asrafabad 'B' Scheme.

Enclo.: As stated.

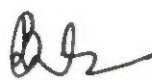
Additional District Magistrate (RR),
North 24 Paraganas, Barasat.



GOVERNMENT OF WEST BENGAL
OFFICE OF THE REFUGEE REHABILITATION COMMISSIONER
VTI BUILDING, 1ST FLOOR, B/7, ACTION AREA III
NEW TOWN, RAJARHAT, KOLKATA - 700 160.

Memo No.L/ 16 /RC.
Land-01/2016

Dated. 19/01/2016

To
The Additional District Magistrate,
R. R. & R. Department,
Barrasat,
Dist : North 24 Parganas.

Sub : Issuance of NOC ' to use land pertaining to the R.R. & R. Department for the construction of a Night Shelter/shelter for Urban homeless on the part of LOP-439 of Asrafabad 'B' scheme in mouza-Asrafabad under J.L.No. 84, C.S.Dag No. 540(P), 541(P) & 543(P) In Habra Municipality, Ward No. 22 in P.S. Habra, Dist : North 24 Parganas.

Ref: His Memo No. 448/RR/Bst. Dt. 21.12.15.

With reference to the above, the undersigned is to inform that R. R. & R. Directorate has no objection over a portion of LOP-439 of Asrafabad 'B' Scheme measuring 08 Cattahs of land for the construction of a Night shelter/shelter for urban Homeless by the Habra Municipality if the land in question belongs to the R. R. & R. Department.

It is for his kind information.

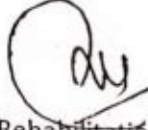

Deputy Refugee Rehabilitation Commissioner
R. R. & R. Directorate, West Bengal.

Memo No.L/ _____ /RC.

Dated. _____ 2016

Copy forwarded for information to :

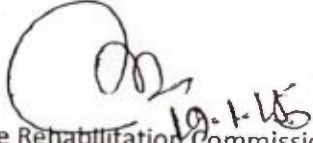
The Commissioner-in-Department, R. R. & R. Department, Kolkata.

Deputy Refugee Rehabilitation Commissioner,
R. R. & R. Directorate, West Bengal.

EXECUTIVE SUMMARY

Project Details

1	State	:	West Bengal
2	City	:	Habra
3	Project Name	:	Shelter for Urban Homeless of Habra under NULM
4	Project Cost (Rs. In Lacs)	:	155.92
5	Central Share (Rs. In Lacs)	:	116.87
6	State Share (Rs. In Lacs)	:	39.06
7	SOR Adopted	:	PWD (WB) SoR w.e.f. 1.7.14

Project Contributions (Physical + Financial) (Rs. In lacs)

Sl No.	Scheme Component	Quantity	Unit	Rate (in Rs./unit)	Proposed project cost (in lakh)	Appraised Project Cost (in lakh)	Central Share	State Govt. Share
1	Construction of 50 beded four storied Shelter including Sanitary Plumbing and Internal Electrification.	1	No.	10909551.00	109.10	109.10	81.82	27.27
2	Cost for furniture and Utensils	1	No.	870500.00	8.71	8.71	6.53	2.18
3	Service Conections (WBSEDCL)	1	LS	50000.00	0.50	0.50	0.38	0.13
4	Fire fighting arrangement	1	LS	40000.00	0.40	0.40	0.30	0.10
Total Cost					118.70	118.70	89.03	29.68
Operation and maintenance cost								
1	O & M Cost for maintenance of assets created for five year	5	Yrs	602000.00	30.10	30.10	22.50	7.60
Other Cost								
1	DPR Preparation, project management, supervision & Quality control	% total cost		3%	3.56	3.56	2.67	0.89
2	Contingency	% total cost		3%	3.56	3.56	2.67	0.89
Grand Total =					155.92	155.92	116.87	39.06

Sub-Assistant Engineer
HABRA MUNICIPALITY

CHAIRMAN
HABRA MUNICIPALITY