



রাজ্য নগর উন্নয়ন সংস্থা

SUDA

STATE URBAN DEVELOPMENT AGENCY

"ইলগাস ভবন", এইচ-সি ব্লক, সেক্টর-৩, বিধাননগর, কলকাতা-৭০০ ১০৬, পশ্চিমবঙ্গ  
"ILGUS BHAVAN", H-C Block, Sector - III, Bidhannagar, Kolkata - 700 106, West Bengal

SUDA-Health/144/08/ ৭৬৬৭

26.11.2019

ক্রমিক নং .....

তারিখ .....

From : Director, SUDA

To : Jt. Secretary, *Ng.*  
Dept. of Health and Family Welfare  
Swasthya Bhawan  
Salt Lake City

Sub: Submission of Utilization Certificate for the period from 12/09/2019 to 19/11/2019 in Connection with Community Based Primary Health Care Services in 63 Non-KMA ULBs and HHW Scheme in 11 Non-KMA ULBs.

Ref. :- Sanction order no. 67(Sanction)/HF/P/P&B/HFW-13/1/2018 dt. 28.05.2019 and 358 (Sanction)/HF/P/P&B/PHP/HFW-13/1/2018 dt. 11.07.2019

Madam,

With reference to the above mentioned G.Os, Utilization Certificate for the period from 12.09.2019 to 19.11.2019 in connection with Community Based Primary Health Care Services in 63 Non-KMA ULBs and HHW Scheme in 11 Non-KMA ULBs is enclosed at Annexure – I for your kind information.

Yours faithfully

*Self*

Director

Dt. .11.2019

SUDA-Health/144/08/ /1(2)

Copy forwarded for kind information to :

1. The Senior P.A to the Principal Secretary, UD & MA Department
2. The Asst. Secretary, P & B Branch, Dept of H & FW

Director

Received  
Contents Not Verified  
*llb* 27/11/2019  
Health and F.W. Deptt.  
Govt. of West Bengal  
Swasthya Bhawan  
D/N<sup>o</sup>. 6646

দূরভাষ : ২৩৫৮ ৬৪০৩ / ৫৭৬৭, ফ্যাক্স : ২৩৫৮ ৫৮০০

Tel : 2358 6403/5767, Fax : 2358 5800, E-mail : wbsudadir@gmail.com

Account Section : 2358 6408

Utilization Certificate in respect of Grant-in-Aid

1.	Name of the Grantee Institution (S)	: Sate Urban Development Agency
2.	Sanctioning Authority	: Jt. Secretary, Department of Health & Family Welfare
3.	Sanction Order Number & Date	: 67(Sanction)/HF/P/P&B/HFW-13/1/2018 dt. 28.05.2019 and 358 (Sanction)/HF/P/P & B/PHP/HFW-13/1/2018 dt. 11.07.2019
4.	Amount Sanctioned	: 2,64,00,000/- and 6,00,00,000/-
5.	Drawing & Disbursing Officer	: Director, State Urban Development Agency
6.	Treasury / PAO	: Kolkata Pay & Accounts Office (III)
7.	Bill No. & Date	: SUDA-19/2019-20 dt. 29.05.2019 and SUDA-35/2019-20 dt. 11.07.2019
8.	T.V No. & Date	: 2210121 dt. 31.05.2019 and 221056 dt. 15.07.2019
9.	Amount Drawn	: Rs. 2,64,00,000/- and Rs. 6,00,00,000/-
10.	Unspent balance of Previous period, if any	: Rs. 2,21,07,916/-
11.	Amount Utilized	: Rs 1,75,05,138/-
12.	Unspent Balance, if any, in current period	: Rs. 46,02,778/-
13.	Purpose of Utilization	: Implementation of Community based Primary Health Care Services in 63 Non-KMA ULBs & HHW Scheme in 11 Non-KMA ULBs.

CERTIFICATE

Certified that I have satisfied myself that the conditions on which the Grant-in- Aid was sanctioned have been duly fulfilled and that I have exercised the following checks to see that the money was actually utilized for the purpose for which it was sanctioned.

The unspent fund will be adjusted against the Grant-in-Aid to be sanctioned and paid in the current Financial Year.

Kinds of checks exercised:

1. U.C submitted by the ULBs
2. Books of Accounts
3. Original Bill, Receipts and Vouchers
4. Bank Statement
5. Physical Progress

*Y. Hore*  
20.11.19.  
Finance Officer  
State Urban Development Agency  
Govt. of West Bengal

Signature of Sanctioning Authority  
Date:



Submitted on 14-09-19

g/c

## রাজ্য নগর উন্নয়ন সংস্থা

### STATE URBAN DEVELOPMENT AGENCY

“ইলগাস ভবন”, এইচ-সি ব্লক, সেক্টর-৩, বিধাননগর, কলকাতা-৭০০ ১০৬, পশ্চিমবঙ্গ

“ILGUS BHAVAN”, H-C Block, Sector - III, Bidhannagar, Kolkata - 700 106, West Bengal

SUDA-Health/144/08/১১৩৭

13.09.2019

ক্রমিক নং .....

তারিখ .....

From : Director, SUDA

To : Jt. Secretary, Ng  
Dept. of Health and Family Welfare  
Swasthya Bhawan  
Salt Lake City

Sub: Submission of Utilization Certificate for the period from 01/04/2019 to 11/09/2019 in Connection with Community Based Primary Health Care Services in 63 Non-KMA ULBs and HHW Scheme in 11 Non-KMA ULBs.

Ref. :- Sanction order no. 67(Sanction)/HF/P/P&B/HFW-13/1/2018 dt. 28.05.2019 and 358 (Sanction)/HF/P/P&B/PHP/HFW-13/1/2018 dt. 11.07.2019

Madam,

With reference to the above mentioned G.Os, Utilization Certificate for the period from 01.04.2019 to 11.09.2019 in connection with Community Based Primary Health Care Services in 63 Non-KMA ULBs and HHW Scheme in 11 Non-KMA ULBs is enclosed at Annexure – I for your kind information. Furthermore, this is to state that a sum of Rs. 1,09,14,075/- has been surrendered to state exchequer on 12.04.2019 in pursuance of F.D order no. 5536-F(Y) dt. 04.09.2019 and 2013-F(Y) dt. 01.04.2019, copy of respective challan is enclosed herewith for your ready reference.

Yours faithfully

Encl. : As stated.

  
Director

SUDA-Health/144/08/১১৩৭(2)

Dt. 13.09.2019

Copy forwarded for kind information to :

1. The Senior P.A to the Principal Secretary, UD & MA Department
2. The Asst. Secretary, P & B Branch, Dept of H & FW

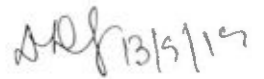
  
Director

Received  
Contents Not Verified  
  
27/11/2019  
Health and F.W. Deptt.  
Govt. of West Bengal  
Swasthya Bhavan  
Dt No: 6645

দূরভাষ : ২৩৫৮ ৬৪০৩ / ৫৭৬৭, ফ্যাক্স : ২৩৫৮ ৫৮০০

Tel : 2358 6403/5767, Fax : 2358 5800, E-mail : wbsudadir@gmail.com

Account Section : 2358 6408

**SUDA**

৩৭৯  
রাজ্য নগর উন্নয়ন সংস্থা

**STATE URBAN DEVELOPMENT AGENCY**

“ইলগাস ভবন”, এইচ-সি ব্লক, সেক্টর-৩, বিধাননগর, কলকাতা-৭০০ ১০৬, পশ্চিমবঙ্গ  
“ILGUS BHAVAN”, H-C Block, Sector - III, Bidhannagar, Kolkata - 700 106, West Bengal

SUDA-67/2006 Pt. III/16 / 7651

21.11.2019

ক্রমিক নং .....

তারিখ 26 .....

From: Director, SUDA

To: The Joint Secretary, Ng.  
Department of Health & Family Welfare  
Swasthya Bhavan  
Govt. of West BengalSub: Requisition of fund for Community Based Primary Health Care Services  
and HHW scheme 71 ULBs

Sir,

Enclosed herewith Utilisation Certificate for the fund released for payment of salary, drug and others for the period 01.04.2019 to 11.09.2019 vide memo no. SUDA-Health/144/08/6437 dt. 13.09.2019 (copy enclosed for ready reference).

Requisition of fund is placed herewith for an amount of Rs. 3,02,61,393.00/- (Three Crores Two Lakhs Sixty One Thousand Three Hundred and Ninety Three Only) for salary, drug and others for the period January 2019 to March 2019 for 71 ULBs, details of which is enclosed herewith.

Thanking you,

Yours faithfully,

21/11/19  
Director, SUDA

Received  
Contents Not Verified  
26/11/2019  
Health and F.W. Deptt.  
Govt. of West Bengal  
Swasthya Bhavan  
No: 6599

Memo No. SUDA-67/2006 Pt. III/16 / 7651/1

21.11.2019

26

Copy forwarded to:

1. Sr. PA to the Principal Secretary, UD & MA Department, Government of West Bengal

26/11/19

21/11/19  
Director, SUDA

দূরভাষ : ২৩৫৮ ৬৪০৩ / ৫৭৬৭, ফ্যাক্স : ২৩৫৮ ৫৮০০

Tel : 2358 6403/5767, Fax : 2358 5800, E-mail : wbsudadir@gmail.com

Account Section : 2358 6408

# রাজ্য নগর উন্নয়ন সংস্থা



## STATE URBAN DEVELOPMENT AGENCY

“ইলগাস ভবন”, এইচ-সি ব্লক, সেক্টর-৩, বিধাননগর, কলকাতা-৭০০ ১০৬, পশ্চিমবঙ্গ  
“ILGUS BHAVAN”, H-C Block, Sector - III, Bidhannagar, Kolkata - 700 106, West Bengal

ক্রমিক নং .....

তারিখ .....

### Requisition of fund from DHFW for CBPHCS project (71 ULBs) for 3<sup>rd</sup> quarter FY 2019-20

Fund required for salary for a quarter	Fund required for drugs and others	Total fund required (a+b)	Balance left with SUDA as on 20.11.2019	Total fund to be released by DHFW for 3 <sup>rd</sup> quarter FY 2019-20 (c-d)
(a)	(b)	(c)	(d)	(e)
2,68,64,171.00	80,00,000.00	3,48,64,171.00	46,02,778.00	3,02,61,393.00
Rupees Three Crores Two Lakhs Sixty One Thousand Three Hundred and Ninety Three Only				

দূরভাষ : ২৩৫৮ ৬৪০৩ / ৫৭৬৭, ফ্যাক্স : ২৩৫৮ ৫৮০০

Tel : 2358 6403/5767, Fax : 2358 5800, E-mail : wbsudadir@gmail.com

Account Section : 2358 6408

**STATE URBAN DEVELOPMENT AGENCY**  
**Community Based Primary Health Care Services**  
 Ledger Account

1-Apr-2019 to 20-Nov-2019

Page 1

Date	Particulars	Vch Type	Vch No.	Debit	Credit
1-4-2019	By <b>Opening Balance</b>				<b>1,10,97,667.15</b>
2-4-2019	To <b>Profession Tax</b>	Payment	SUDA/4/19-20	1,82,792.00	
3-4-2019	To <b>Cash-in-Hand</b>	Payment	SUDA/38/19-20	800.00	
12-4-2019	To <b>Kolkata Pay &amp; Accounts Office - III</b>	Payment	SUDA/95/19-20	1,09,14,075.00	
31-5-2019	By <b>Kolkata Pay &amp; Accounts Office - III</b>	Receipt	SUDA/16/19-20		2,64,00,000.00
6-6-2019	To <b>Kolkata Pay &amp; Accounts Office - III</b>	Payment	SUDA/417/19-20	1,96,18,376.00	
15-7-2019	By <b>Kolkata Pay &amp; Accounts Office - III</b>	Receipt	SUDA/38/19-20		6,00,00,000.00
19-7-2019	To <b>Kolkata Pay &amp; Accounts Office - III</b>	Payment	SUDA/692/19-20	67,81,233.00	
26-8-2019	To <b>Kolkata Pay &amp; Accounts Office - III</b>	Payment	SUDA/888/19-20	3,26,81,605.00	
11-9-2019	To <b>Kolkata Pay &amp; Accounts Office - III</b>	Payment	SUDA/988/19-20	52,10,870.00	
15-11-2019	To <b>Kolkata Pay &amp; Accounts Office - III</b>	Payment	SUDA/1353/19-20	1,75,05,138.00	
				<u>9,28,94,889.00</u>	<u>9,74,97,667.15</u>
	To <b>Closing Balance</b>			<u>46,02,778.15</u>	
				<b>9,74,97,667.15</b>	<b>9,74,97,667.15</b>

## রাজ্য নগর উন্নয়ন সংস্থা

## STATE URBAN DEVELOPMENT AGENCY

“ইলগাস ভবন”, এইচ-সি ব্লক, সেক্টর-৩, বিধাননগর, কলকাতা-৭০০ ১০৬, পশ্চিমবঙ্গ

“ILGUS BHAVAN”, H-C Block, Sector - III, Bidhannagar, Kolkata - 700 106, West Bengal

ক্রমিক নং .....SUDA-67/2006-(Pt - III)/16/

তারিখ .....11.2019.....

**From :** Director, SUDA  
**To :** Jt. Secretary, Govt. of West Bengal  
 Department of Health & Family Welfare  
 Swasthya Bhawan

**Sub. :** Requisition of fund in respect of Community Based Primary Health Care Services and HHW Scheme.

**Madam,**

This is to state that we have received Rs. 2,64,00,000/- vide memo no. 67(Sanction)/HF/P/P&B/HFW-13/1/2018 dt. 28.05.2019 and Rs. 6,00,00,000/- vide memo no. 358 (Sanction)/HF/P/P & B/PHP/HFW-13/1/2018 dt. 11.07.2019, out of which Rs. 7,53,89,751/ has already been utilized upto 11.09.2019 and afterwards Rs. 1,75,05,138/- has already been transferred upto 19.11.2019. We have submitted UC upto 11.09.2019 vide SUDA-Health/144/08/6437 dt. 13.09.2019 in respect of submission of Utilization Certificate (UC) (copy enclosed for ready reference). We will furnish the next UC I due course.

Meanwhile, a sum of Rs. 3,00,00,000/- (Rupees Three Crore only) is required for smooth implementation of CBPHCS and HHW Scheme in 71 ULBs upto march, 2019 for the F.Y 2019-20.

Thanking you.

**Yours faithfully**

**Encl. : As stated**

**Director, SUDA**

SUDA-67/2006 (PT-III)/16

**Dt. ... .11.2019**

**CC**

**1. Sr. P.A to the Secretary, UD & MA Department**

**Director, SUDA**

## রাজ্য নগর উন্নয়ন সংস্থা

## STATE URBAN DEVELOPMENT AGENCY

“ইলগাস ভবন”, এইচ-সি ব্লক, সেক্টর-৩, বিধাননগর, কলকাতা-৭০০ ১০৬, পশ্চিমবঙ্গ

“ILGUS BHAVAN”, H-C Block, Sector - III, Bidhannagar, Kolkata - 700 106, West Bengal

ক্রমিক নং .....SUDA-67/2006.(Pt - III)/16/

তারিখ .....11.2019.....

From : Director, SUDA  
 To : Jt. Secretary, Govt. of West Bengal  
 Department of Health & Family Welfare  
 Swasthya Bhawan

Sub. : Requisition of fund in respect of Community Based Primary Health Care Services and HHW Scheme.

Madam,

I am to refer this office earlier communication vide no. SUDA-Health/144/08/6437 dt. 13.09.2019 in respect of submission of Utilization Certificate (UC) upto 11.09.2019 (copy enclosed for ready reference). Furthermore, this is to state that a sum of Rs. 3,00,00,000/- (Rupees Three Crore only) is required for implementation of CBPHCS and HHW Scheme in 71 ULBs during the F.Y 2019-20.

Thanking you.

Yours faithfully

Encl. : As stated

Director, SUDA

SUDA-67/2006 (PT-III)/16

Dt. ... .11.2019

CC

1. Sr. P.A to the Secretary, UD & MA Department

Director, SUDA



Submitted on 14-09-19

## রাজ্য নগর উন্নয়ন সংস্থা

### STATE URBAN DEVELOPMENT AGENCY

“ইলগাস ভবন”, এইচ-সি ব্লক, সেক্টর-৩, বিধাননগর, কলকাতা-৭০০ ১০৬, পশ্চিমবঙ্গ

“ILGUS BHAVAN”, H-C Block, Sector - III, Bidhannagar, Kolkata - 700 106, West Bengal

SUDA-Health/144/08/৬৩৭

13.09.2019

ক্রমিক নং .....

তারিখ .....

From : Director, SUDA

To : Jt. Secretary,  
Dept. of Health and Family Welfare  
Swasthya Bhawan  
Salt Lake City

Sub: Submission of Utilization Certificate for the period from 01/04/2019 to 11/09/2019 in Connection with Community Based Primary Health Care Services in 63 Non-KMA ULBs and HHW Scheme in 11 Non-KMA ULBs.

Ref. :- Sanction order no. 67(Sanction)/HF/P/P&B/HFW-13/1/2018 dt. 28.05.2019 and 358 (Sanction)/HF/P/P&B/PHP/HFW-13/1/2018 dt. 11.07.2019

Madam,

With reference to the above mentioned G.Os, Utilization Certificate for the period from 01.04.2019 to 11.09.2019 in connection with Community Based Primary Health Care Services in 63 Non-KMA ULBs and HHW Scheme in 11 Non-KMA ULBs is enclosed at Annexure – I for your kind information. Furthermore, this is to state that a sum of Rs. 1,09,14,075/- has been surrendered to state exchequer on 12.04.2019 in pursuance of F.D order no. 5536-F(Y) dt. 04.09.2019 and 2013-F(Y) dt. 01.04.2019, copy of respective challan is enclosed herewith for your ready reference.

Yours faithfully

Encl. : As stated.

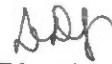

Director

SUDA-Health/144/08/৬৩৭(2)

Dt. 13.09.2019

Copy forwarded for kind information to :

1. The Senior P.A to the Principal Secretary, UD & MA Department
2. The Asst. Secretary, P & B Branch, Dept of H & FW

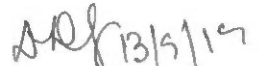

Director

দূরভাষ : ২৩৫৮ ৬৪০৩ / ৫৭৬৭, ফ্যাক্স : ২৩৫৮ ৫৮০০

Tel : 2358 6403/5767, Fax : 2358 5800, E-mail : wbsudadir@gmail.com

Account Section : 2358 6408

**SUDA**

## রাজ্য নগর উন্নয়ন সংস্থা

### STATE URBAN DEVELOPMENT AGENCY

“ইলগাস ভবন”, এইচ-সি ব্লক, সেক্টর-৩, বিধাননগর, কলকাতা-৭০০ ১০৬, পশ্চিমবঙ্গ  
“ILGUS BHAVAN”, H-C Block, Sector - III, Bidhannagar, Kolkata - 700 106, West Bengal

ক্রমিক নং .....SUDA-67/2006.(Pt – III)/16/

তারিখ .....11.2019.....

**From :** Director, SUDA  
**To :** Jt. Secretary, Govt. of West Bengal  
Department of Health & Family Welfare  
Swasthya Bhawan

**Sub. :** Requisition of fund in respect of Community Based Primary Health Care Services and HHW Scheme.

**Madam,**

I am to refer this office earlier communication vide no. SUDA-Health/144/08/6437 dt. 13.09.2019 in respect of submission of Utilization Certificate (UC) upto 11.09.2019 (copy enclosed for ready reference). Furthermore, this is to state that a sum of Rs. 3,00,00,000/- (Rupees Three Crore only) is required for implementation of CBPHCS and HHW Scheme in 71 ULBs during the F.Y 2019-20.

Thanking you.

**Yours faithfully**

**Encl. : As stated**

**Director, SUDA**

SUDA-67/2006 (PT-III)/16

**Dt. ... .11.2019**

**CC**

**1. Sr. P.A to the Secretary, UD & MA Department**

**Director, SUDA**

e-Advice For Personal Ledger Account/Local Fund Account/Provident Fund Account/Other Deposit Account  
(For Transfer from one Operator to another Operator)

Operator Code : 19

Operator Designation : DIRECTOR, SUDA

Head of Account : 00-8448-00-120-00-013-0-23-00

Local Advice Id : 118

Memo No. : SUDA-67/2006(PT.-III)/16/9709

Local Advice Date : 20/08/2019

Memo Date : 20/08/2019

For use of the Operator												For use of Treasury/PAO	
Details of Payee Operator			Details of Recipient Operator										
Reference No.	Scheme Id of Operator	Scheme Description of Operator	Payee Treasury code	Payee Treasury Name	Operator Code of Payee	Designation of Payee Operator	Scheme Id of Payee Operator	Scheme Description of Payee Operator	Head of Account of the Payee Operator	Amount(Rs.)	Purpose	Approved	Objected
20190800002137	21097	COMMUNITY BASED PRIMARY HEATH CARE	DAF	Mirik	1	CHAIRMAN MIRIK	22454	CBPHCS	00-8448-00-102-00-001-0-07-00	334870	CBPHCS		
20190800002141	21097	COMMUNITY BASED PRIMARY HEATH CARE	MIG	Tamluk	26	Panskura Municipality	22089	CBPHCS	00-8448-00-102-00-001-0-07-00	500659	CBPHCS		
20190800002141	21097	COMMUNITY BASED PRIMARY HEATH CARE	MIG	Tamluk	36	Chairman Tamluk	22089	CBPHCS	00-8448-00-102-00-001-0-07-00	564781	CBPHCS		
20190800002142	21097	COMMUNITY BASED PRIMARY HEATH CARE	PUA	Purulia	20	CHAIRMAN PURULIA	22377	CBPHCS	00-8448-00-102-00-001-0-07-00	604524	CBPHCS		

Pay Rs. 2004834 Rupees(in words) Twenty Lakh Four Thousand Eight Hundred Thirty Four only as transfer.

  
Assistant/Accountant

Signature of PL/LF/PF/OD Operator

Signature of Joint Signatory

Printed By: DEBARATI DATTA GUPTA

It is certified that the payment advice has been generated as per the received during the financial year 2019-20 provide allotment

Page 1 of 1

No. 358(Sanctm)/HR/P/PLD/PHP/HRD-19/1/2019  
Dated.11-07-2019

  
Director  
State Urban Development Agency

Calcutta PAO-III  
Reference Details

For

Xier -To Operator List For Personal Ledger Account/Local Fund Account/Provident Fund Account/Other Deposit Account

Operator Code : 19

Head of Account : 00-8448-00-120-00-013-0-23-00

Operator Name : DIRECTOR, SUDA

Reference Number : 20190800002137

Net Amount : 334870

334870

Reference Date : 19/08/2019

Status : Reference Generated

Sl. No.	Scheme Id	Scheme Description	Payee Treasury Code	Payee Treasury Name	Payee Operator Code	Payee Operator Name	Payee Scheme Id	Payee Scheme Description	Amount	Purpose
1	21097	COMMUNITY BASED	DAF	Mirik	1	CHAIRMAN MIRIK MUNICIPALITY	22454	CBPHCS	334870	CBPHCS

Signature of the Assistant/Accountant

Signature of the Administrator

Signature of Joint Signatory

Printed By : DIPANKAR CHOWDHURY

Printed On : 19/08/2019 4:36 PM

Director

Page 1 of 1

Calcutta PAO-III  
Reference Details

For

Xier -To Operator List For Personal Ledger Account/Local Fund Account/Provident Fund Account/Other Deposit Account

Operator Code : 19

Head of Account : 00-8448-00-120-00-013-0-23-00

Operator Name : DIRECTOR, SUDA

Reference Number : 2019080002141

Net Amount : 1065440

Reference Date : 19/08/2019

Status : Reference Generated

Sl. No.	Scheme Id	Scheme Description	Payee Treasury Code	Payee Treasury Name	Payee Operator Code	Payee Operator Name	Payee Scheme Id	Payee Scheme Description	Amount	Purpose
1	21097	COMMUNITY BASED	MIG	Tamluk	36	Chairman, Tamluk Municipality/	22069	CBPHCS	564781	CBPHCS
2	21097	COMMUNITY BASED	MIG	Tamluk	26	Panskura Municipality (8448)	22069	CBPHCS	500659	CBPHCS

Signature of the Assistant/Accountant

Signature of the Administrator

Printed By : DIPANKAR CHOWDHURY

Printed On : 19/08/2019 4:41 PM

Signature of Joint Signatory

Director  
State Urban Development Agency

Calcutta PAO-III  
Reference Details

Xfer -To Operator List For Personal Ledger Account/Local Fund Account/Provident Fund Account/Other Deposit Account

For

Operator Code : 19

Head of Account : 00-8448-00-120-00-013-0-23-00

Operator Name : DIRECTOR, SUDA

Reference Number : 20190800002142

Net Amount :

604524

Reference Date : 19/08/2019

Status : Reference Generated

Sl. No.	Scheme Id	Scheme Description	Payee Treasury Code	Payee Treasury Name	Payee Operator Code	Payee Operator Name	Payee Scheme Id	Payee Scheme Description	Amount	Purpose
1	21097	COMMUNITY BASED	PUA	Purulia	20	CHAIRMAN PURULLIA	22377	CBPHCS	604524	CBPHCS

Signature of the Assistant/Accountant

Signature of the Administrator

Signature of Joint Signatory

Printed By : DIPANKAR CHOWDHURY

Printed On : 19/08/2019 4:43 PM

Director

State Urban Development Agency

Operator Code : 19

Operator Designation : DIRECTOR, SUDA

Head of Account : 00-8448-00-120-00-013-0-23-00

Local Advice Id : 110

Memo No. : SUDA-67/2006(PT.-III)/16/9701

Local Advice Date : 20/08/2019

Memo Date : 20/08/2019

For use of the Operator											For use of Treasury/PAO		
Reference No.	Details of Payee Operator		Details of Recipient Operator							Amount(Rs.)	Purpose	Approved	Objected
	Scheme Id of Operator	Scheme Description of Operator	Payee Treasury code	Payee Treasury Name	Operator Code of Payee	Designation of Payee Operator	Scheme Id of Payee Operator	Scheme Description of Payee Operator	Head of Account of the Payee Operator				
2019080002091	21097	COMMUNITY BASED PRIMARY HEATH CARE	HGC	Arambagh	14	CHAIRMAN, A RAMBAGH	22119	CBPHCS	00-8448-00-102-00-001-0-07-00	524848	CBPHCS		
2019080002092	21097	COMMUNITY BASED PRIMARY HEATH CARE	NPA	Barasat-I	11	CHAIRMAN, ASHOKNAGA	22093	CBPHCS	00-8448-00-102-00-001-0-07-00	712136	CBPHCS		
2019080002092	21097	COMMUNITY BASED PRIMARY HEATH CARE	NPA	Barasat-I	9	CHAIRMAN, HABRA	22093	CBPHCS	00-8448-00-102-00-001-0-07-00	700947	CBPHCS		
2019080002092	21097	COMMUNITY BASED PRIMARY HEATH CARE	NPA	Barasat-I	10	CHAIRMAN, GOBARDANG	22093	CBPHCS	00-8448-00-102-00-001-0-07-00	500659	CBPHCS		
2019080002093	21097	COMMUNITY BASED PRIMARY HEATH CARE	NPE	Basirhat	4	CHAIRMAN, BADURIA	22155	CBPHCS(SUD A)	00-8448-00-102-00-001-0-07-00	528098	CBPHCS		
2019080002093	21097	COMMUNITY BASED PRIMARY HEATH CARE	NPE	Basirhat	5	CHAIRMAN, TAKI	22155	CBPHCS(SUD A)	00-8448-00-102-00-001-0-07-00	500088	CBPHCS		
2019080002093	21097	COMMUNITY BASED PRIMARY HEATH CARE	NPE	Basirhat	3	Chairman, Basirhat	22155	CBPHCS(SUD A)	00-8448-00-102-00-001-0-07-00	714575	CBPHCS		
2019080002094	21097	COMMUNITY BASED PRIMARY HEATH CARE	NPF	Bongaon	2	CHAIRMAN, BONGAON	22289	CBPHCS	00-8448-00-102-00-001-0-07-00	780654	CBPHCS		
2019080002095	21097	COMMUNITY BASED PRIMARY HEATH CARE	BAA	Bankura	26	CHAIRMAN, BANKURA	22192	COMMUNITY BASED	00-8448-00-102-00-001-0-07-00	657182	CBPHCS		
2019080002095	21097	COMMUNITY BASED PRIMARY HEATH CARE	BAA	Bankura	28	CHAIRMAN, SONAMUKHI	22192	COMMUNITY BASED	00-8448-00-102-00-001-0-07-00	370376	CBPHCS		

Pay Rs. 5989573 Rupees(in words) Fifty Nine Lakh Eighty Nine Thousand Five Hundred Seventy Three only as transfer.

Assistant/Accountant

Signature of PL/LF/PF/OD Operator

Signature of Joint Signatory

Printed By: DEBARATI DATTA GUPTA

It is certified that the payment advice has been generated out of fund received during (Page 1 of 1)

Financial year 20.19... = 20... vide Allotment No. 358 (Sanction) / H/P/PLS/PHH/AFS - 13/1/2018

Dated 11-08-2019

Calcutta PAO-III  
Reference Details

For

Xfer -To Operator List For Personal Ledger Account/Local Fund Account/Provident Fund Account/Other Deposit Account

Operator Code : 19

Head of Account : 00-8448-00-120-00-013-0-23-00

Operator Name : DIRECTOR, SUDA

Reference Number : 2019080002091

Net Amount : 524848

Reference Date : 19/08/2019

Status : Reference Generated

Sl. No.	Scheme Id	Scheme Description	Payee Treasury Code	Payee Treasury Name	Payee Operator Code	Payee Operator Name	Payee Scheme Id	Payee Scheme Description	Amount	Purpose
1	21097	COMMUNITY BASED	HGC	Arambagh	14	CHAIRMAN,ARAMB AGH	22119	CBPHCS	524848 ✓	CBPHCS

Signature of the Assistant/Accountant

Printed By : DIPANKAR CHOWDHURY

Signature of the Administrator

Printed On : 19/08/2019 2:22 PM

Signature of Joint Signatory

Page 1 of 1

Director  
State Urban Development Agency



Calcutta PAO-III  
Reference Details

For

Xfer -To Operator List For Personal Ledger Account/Local Fund Account/Provident Fund Account/Other Deposit Account

Operator Code : 19

Head of Account : 00-8448-00-120-00-013-0-23-00

Operator Name : DIRECTOR, SUDA

Reference Number : 2019080002092

Net Amount : 1913742

Reference Date : 19/08/2019

Status : Reference Generated

Sl. No.	Scheme Id	Scheme Description	Payee Treasury Code	Payee Treasury Name	Payee Operator Code	Payee Operator Name	Payee Scheme Id	Payee Scheme Description	Amount	Purpose
1	21097	COMMUNITY BASED	NPA	Barasat-I	11	CHAIRMAN, ASHOKNAGAR-	22093	CBPHCS	712136 ✓	CBPHCS
2	21097	COMMUNITY BASED	NPA	Barasat-I	10	CHAIRMAN, GOBARDANGA	22093	CBPHCS	500659 ✓	CBPHCS
3	21097	COMMUNITY BASED	NPA	Barasat-I	9	CHAIRMAN, HABRA	22093	CBPHCS	700947 ✓	CBPHCS

Signature of the Assistant/Accountant

Signature of the Administrator

Printed By : DIPANKAR CHOWDHURY

Printed On : 19/08/2019 2:24 PM

Signature of Joint Signatory

Page 1 of 1

Calcutta PAO-III  
Reference Details

For

Xier -To Operator List For Personal Ledger Account/Local Fund Account/Provident Fund Account/Other Deposit Account

Operator Code : 19

Head of Account : 00-8448-00-120-00-013-0-23-00

Operator Name : DIRECTOR, SUDA

Reference Number : 20190800002093

Net Amount : 1742771

Reference Date : 19/08/2019

Status : Reference Generated

Sl. No.	Scheme Id	Scheme Description	Payee Treasury Code	Payee Treasury Name	Payee Operator Code	Payee Operator Name	Payee Scheme Id	Payee Scheme Description	Amount	Purpose
1	21097	COMMUNITY BASED	NPE	Basirhat	4	CHAIRMAN, BADURIA	22155	CBPHCS(SUDA)	528098 ✓	CBPHCS
2	21097	COMMUNITY BASED	NPE	Basirhat	5	CHAIRMAN, TAKI MUNICIPALITY	22155	CBPHCS(SUDA)	500098 ✓	CBPHCS
3	21097	COMMUNITY BASED	NPE	Basirhat	3	Chairman, Basirhat Municipality	22155	CBPHCS(SUDA)	714575 ✓	CBPHCS

Signature of the Assistant/Accountant

Signature of the Administrator

Printed By : DIPANKAR CHOWDHURY

Printed On : 19/08/2019 2:27 PM

Signature of Joint Signatory

Page 1 of 1

Calcutta PAO-III  
Reference Details

For

Xier -To Operator List For Personal Ledger Account/Local Fund Account/Provident Fund Account/Other Deposit Account

Operator Code : 19

Head of Account : 00-8448-00-120-00-013-0-23-00

Operator Name : DIRECTOR, SUDA

Reference Number : 2019080002094

Net Amount : 780654

Reference Date : 19/08/2019

Status : Reference Generated

Sl. No.	Scheme Id	Scheme Description	Payee Treasury Code	Payee Treasury Name	Payee Operator Code	Payee Operator Name	Payee Scheme Id	Payee Scheme Description	Amount	Purpose
1	21097	COMMUNITY BASED	NPF	Bongaon	2	CHAIRMAN, BONGAON	22289	CBPHCS	780654 ✓	CBPHCS

Signature of the Assistant/Accountant

Signature of the Administrator

Signature of Joint Signatory

Printed By : DIPANKAR CHOWDHURY

Printed On : 19/08/2019 2:28 PM

Page 1 of 1

Calcutta PAO-III  
Reference Details

For

Xfer -To Operator List For Personal Ledger Account/Local Fund Account/Provident Fund Account/Other Deposit Account

Operator Code : 19

Head of Account : 00-8448-00-120-00-013-0-23-00

Operator Name : DIRECTOR, SUDA

Reference Number : 2019080002095

Net Amount : 1027558

Reference Date : 19/08/2019

Status : Reference Generated

Sl. No.	Scheme Id	Scheme Description	Payee Treasury Code	Payee Treasury Name	Payee Operator Code	Payee Operator Name	Payee Scheme Id	Payee Scheme Description	Amount	Purpose
1	21097	COMMUNITY BASED	BAA	Bankura	28	CHAIRMAN, SONAMUKHI	22192	COMMUNITY BASED PRIMARY HEALTH CARE SERVICES	370376 ✓	CBPHCS
2	21097	COMMUNITY BASED	BAA	Bankura	26	CHAIRMAN, BANKURA	22192	COMMUNITY BASED PRIMARY HEALTH CARE SERVICES	657182 ✓	CBPHCS

Signature of the Assistant/Accountant

Signature of the Administrator

Signature of Joint Signatory

Printed By : DIPANKAR CHOWDHURY

Printed On : 19/08/2019 2:30 PM

Page 1 of 1

*[Handwritten Signature]*  
Director

## Calcutta PAO-III

e-Advice For Personal Ledger Account/Local Fund Account/Provident Fund Account/Other Deposit Account  
(For Transfer from one Operator to another Operator)

Operator Code : 19

Operator Designation : DIRECTOR, SUDA

Head of Account : 00-8448-00-120-00-013-0-23-00

Local Advice Id : 111

Memo No. : SUDA-67/2006(PT.-III)/16/9702

Local Advice Date : 20/08/2019

Memo Date : 20/08/2019

For use of the Operator											For use of Treasury/PAC			
Reference No.	Details of Payee Operator		Details of Recipient Operator								Amount(Rs.)	Purpose	Approved	Objected
	Scheme Id of Operator	Scheme Description of Operator	Payee Treasury code	Payee Treasury Name	Operator Code of Payee	Designation of Payee Operator	Scheme Id of Payee Operator	Scheme Description of Payee Operator	Head of Account of the Payee Operator					
2019080002096	21097	COMMUNITY BASED PRIMARY HEATH CARE	MUA	Berhampore	20	CHAIRMAN BELDANGA	22184	CBPHCS	00-8448-00-102-00-001-0-07-00	434327	CBPHCS			
2019080002096	21097	COMMUNITY BASED PRIMARY HEATH CARE	MUA	Berhampore	16	CHAIRMAN BERHAMPOR	22184	CBPHCS	00-8448-00-102-00-001-0-07-00	777656	CBPHCS			
2019080002097	21097	COMMUNITY BASED PRIMARY HEATH CARE	NAD	Ranaghat	19	Chairman, Ranaghat	22099	CBPHCS	00-8448-00-102-00-001-0-07-00	447342	CBPHCS			
2019080002097	21097	COMMUNITY BASED PRIMARY HEATH CARE	NAD	Ranaghat	20	Chairman, Santipur	22099	CBPHCS	00-8448-00-102-00-001-0-07-00	761880	CBPHCS			
2019080002097	21097	COMMUNITY BASED PRIMARY HEATH CARE	NAD	Ranaghat	23	Chairman, Coopers Camp	22099	CBPHCS	00-8448-00-102-00-001-0-07-00	436786	CBPHCS			
2019080002097	21097	COMMUNITY BASED PRIMARY HEATH CARE	NAD	Ranaghat	21	Chairman, Birnagar	22099	CBPHCS	00-8448-00-102-00-001-0-07-00	434318	CBPHCS			
2019080002097	21097	COMMUNITY BASED PRIMARY HEATH CARE	NAD	Ranaghat	22	Chairman, Taherpur,	22099	CBPHCS	00-8448-00-102-00-001-0-07-00	341626	CBPHCS			
2019080002098	21097	COMMUNITY BASED PRIMARY HEATH CARE	BAB	Bishnupur	10	CHAIRMAN BISHNUPUR	22024	CBPHCS	00-8448-00-102-00-001-0-07-00	507315	CBPHCS			
2019080002098	21097	COMMUNITY BASED PRIMARY HEATH CARE	BRB	Bolpur	2	CHAIRMAN, BOLPUR	22478	CBPHCS(SUDA)	00-8448-00-102-00-001-0-07-00	416437	CBPHCS			
2019080002100	21097	COMMUNITY BASED PRIMARY HEATH CARE	NAC	Kalyani	15	CHAIRMAN, CHAKDAHA	22068	CBPHCS	00-8448-00-102-00-001-0-07-00	540545	CBPHCS			

Pay Rs. 5098492 Rupees(in words) Fifty Lakh Ninety Eight Thousand Four Hundred Ninety Two only as transfer.

Assistant/Accountant

Signature of PL/LF/PF/OD Operator

Signature of Joint Signatory

Printed By: DEBARATI DATTA GUPTA

It is certified that the payment advice has been generated out of fund received during the

Page 1 of 1

Finance No. 358(Sanctm)/HF/P/PRD/HP/HFw -13/1/2019 vide Allotment

Dated.11-07-2019

  
 Director  
 State Urban Development Agency

Calcutta PAO-III  
Reference Details

For

Xier -To Operator List For Personal Ledger Account/Local Fund Account/Provident Fund Account/Other Deposit Account

Operator Code : 19

Head of Account : 00-8448-00-120-00-013-0-23-00

Operator Name : DIRECTOR, SUDA

Reference Number : 2019080002096

Net Amount : 1212283

Reference Date : 19/08/2019

Status : Reference Generated

Sl. No.	Scheme Id	Scheme Description	Payee Treasury Code	Payee Treasury Name	Payee Operator Code	Payee Operator Name	Payee Scheme Id	Payee Scheme Description	Amount	Purpose
1	21097	COMMUNITY BASED	MUA	Berhampore-I	18	CHAIRMAN BERHAMPORE	22184	CBPHCS	777956	CBPHCS
2	21097	COMMUNITY BASED	MUA	Berhampore-I	20	CHAIRMAN BELDANGA	22184	CBPHCS	434327	CBPHCS

Signature of the Assistant/Accountant

Printed By : DIPANKAR CHOWDHURY

Signature of the Administrator

Printed On : 19/08/2019 2:32 PM

Signature of Joint Signatory

Page 1 of 1

Director  
State Urban Development Agency

Calcutta PAO-III  
Reference Details

For

Xfer -To Operator List For Personal Ledger Account/Local Fund Account/Provident Fund Account/Other Deposit Account

Operator Code : 19 Head of Account : 00-8448-00-120-00-013-0-23-00

Operator Name : DIRECTOR, SUDA

Reference Number : 2019080002097 Net Amount : 2421912

Reference Date : 19/08/2019

Status : Reference Generated

Sl. No.	Scheme Id	Scheme Description	Payee Treasury Code	Payee Treasury Name	Payee Operator Code	Payee Operator Name	Payee Scheme Id	Payee Scheme Description	Amount	Purpose
1	21097	COMMUNITY BASED	NAD	Ranaghat	21	Chairman, Birnagar Municipality	22099	CBPHCS	434318 ✓	CBPHCS
2	21097	COMMUNITY BASED	NAD	Ranaghat	23	Chairman, Coopers Camp Notified Area	22099	CBPHCS	436766 ✓	CBPHCS
3	21097	COMMUNITY BASED	NAD	Ranaghat	22	Chairman, Taherpur, Notified Area	22099	CBPHCS	341626 ✓	CBPHCS
4	21097	COMMUNITY BASED	NAD	Ranaghat	20	Chairman, Santipur Municipality	22099	CBPHCS	761860 ✓	CBPHCS
5	21097	COMMUNITY BASED	NAD	Ranaghat	19	Chairman, Ranaghat Municipality.	22099	CBPHCS	447342 ✓	CBPHCS

Signature of the Assistant/Accountant

Signature of the Administrator

Signature of Joint Signatory

Printed By : DIPANKAR CHOWDHURY

Printed On : 19/08/2019 2:38 PM

Page 1 of 1

Calcutta PAO-III  
Reference Details

For

Xfer - To Operator List For Personal Ledger Account/Local Fund Account/Provident Fund Account/Other Deposit Account

Operator Code : 19

Head of Account : 00-8448-00-120-00-013-0-23-00

Operator Name : DIRECTOR, SUDA

Reference Number : 2019080002098

Net Amount : 507315

Reference Date : 19/08/2019

Status : Reference Generated

Sl. No.	Scheme Id	Scheme Description	Payee Treasury Code	Payee Treasury Name	Payee Operator Code	Payee Operator Name	Payee Scheme Id	Payee Scheme Description	Amount	Purpose
1	21097	COMMUNITY BASED	BAB	Bishnupur	10	CHAIRMAN BISHNUPUR	22024	CBPHCS	507315	CBPHCS

Signature of the Assistant/Accountant



Printed By : DIPANKAR CHOWDHURY

Signature of the Administrator



Printed On : 19/08/2019 2:39 PM

Signature of Joint Signatory

Page 1 of 1

Director  
Joint Development Agency



Calcutta PAO-III  
Reference Details

For

Xier -To Operator List For Personal Ledger Account/Local Fund Account/Provident Fund Account/Other Deposit Account

Operator Code : 19

Head of Account : 00-8448-00-120-00-013-0-23-00

Operator Name : DIRECTOR, SUDA

Reference Number : 2019080002099

Net Amount : 416437

Reference Date : 19/08/2019

Status : Reference Generated

Sl. No.	Scheme Id	Scheme Description	Payee Treasury Code	Payee Treasury Name	Payee Operator Code	Payee Operator Name	Payee Scheme Id	Payee Scheme Description	Amount	Purpose
1	21097	COMMUNITY BASED	BRB	Bolpur	2	CHAIRMAN, BOLPUR	22479	CBPHCS(SUDA)	416437	CBPHCS

Signature of the Assistant/Accountant

Signature of the Administrator

Printed By : DIPANKAR CHOWDHURY

Printed On : 19/08/2019 2:40 PM

Signature of Joint Signatory

Page 1 of 1

Calcutta PAO-III  
Reference Details

Xier -To Operator List For Personal Ledger Account/Local Fund Account/Provident Fund Account/Other Deposit Account

Operator Code : 19

Head of Account : 00-8448-00-120-00-013-0-23-00

Operator Name : DIRECTOR, SUDA

Reference Number : 2019080002100

Net Amount : 540545

Reference Date : 19/08/2019

Status : Reference Generated

Sl. No.	Scheme Id	Scheme Description	Payee Treasury Code	Payee Treasury Name	Payee Operator Code	Payee Operator Name	Payee Scheme Id	Payee Scheme Description	Amount	Purpose
1	21097	COMMUNITY BASED	NAC	Kalyani	15	CHAIRMAN, CHAKDAHAI	22068	CBPHCS	540545 ✓	CBPHCS

Signature of the Assistant/Accountant

Signature of the Administrator

Signature of Joint Signatory

Printed By : DIPANKAR CHOWDHURY

Printed On : 19/08/2019 2:41 PM

Page 1 of 1

Director  
Director  
Director

## Calcutta PAO-III

e-Advice For Personal Ledger Account/Local Fund Account/Provident Fund Account/Other Deposit Account

(For Transfer from one Operator to another Operator)

Operator Code : 19

Operator Designation : DIRECTOR, SUDA

Head of Account : 00-8448-00-120-00-013-0-23-00

Local Advice Id : 112

Memo No. : SUDA-67/2006(PT-III)/18/9703

Local Advice Date : 20/08/2019

Memo Date : 20/08/2019

For use of the Operator											For use of Treasury/PAO		
Reference No.	Details of Payee Operator		Details of Recipient Operator							Amount(Rs.)	Purpose	Approved	Objected
	Scheme Id of Operator	Scheme Description of Operator	Payee Treasury code	Payee Treasury Name	Operator Code of Payee	Designation of Payee Operator	Scheme Id of Payee Operator	Scheme Description of Payee Operator	Head of Account of the Payee Operator				
2019080002101	21097	COMMUNITY BASED PRIMARY HEATH CARE	MIC	Ghatal	9	Chairman, Chandrakona	22339	CBPHCS	00-8448-00-102-00-001-0-07-00	379067	CBPHCS		
2019080002101	21097	COMMUNITY BASED PRIMARY HEATH CARE	MIC	Ghatal	6	Chairman, Ghatal	22339	CBPHCS	00-8448-00-102-00-001-0-07-00	509493	CBPHCS		
2019080002101	21097	COMMUNITY BASED PRIMARY HEATH CARE	MIC	Ghatal	7	Chairman, Kharar	22339	CBPHCS	00-8448-00-102-00-001-0-07-00	413894	CBPHCS		
2019080002101	21097	COMMUNITY BASED PRIMARY HEATH CARE	MIC	Ghatal	8	Chairman, Khirpai	22339	CBPHCS	00-8448-00-102-00-001-0-07-00	343521	CBPHCS		
2019080002101	21097	COMMUNITY BASED PRIMARY HEATH CARE	MIC	Ghatal	10	Chairman, Ramjibanpur	22339	CBPHCS	00-8448-00-102-00-001-0-07-00	424286	CBPHCS		
2019080002102	21097	COMMUNITY BASED PRIMARY HEATH CARE	MIB	Contal	2	CHAIRMAN CONTAL	22367	CBPHCS	00-8448-00-102-00-001-0-07-00	113719	CBPHCS		
2019080002103	21097	COMMUNITY BASED PRIMARY HEATH CARE	COA	Cooch Behar-I	12	Chairman, Cooch Behar	22525	CBPHCS	00-8448-00-102-00-001-0-07-00	404573	CBPHCS		
2019080002105	21097	COMMUNITY BASED PRIMARY HEATH CARE	BUG	Katwa	7	CHAIRMAN DAINHAT	22003	CBPHCS	00-8448-00-102-00-001-0-07-00	375126	CBPHCS		
2019080002105	21097	COMMUNITY BASED PRIMARY HEATH CARE	BUG	Katwa	6	CHAIRMAN KATWA	22003	CBPHCS	00-8448-00-102-00-001-0-07-00	505830	CBPHCS		
2019080002106	21097	COMMUNITY BASED PRIMARY HEATH CARE	UDA	Islampur	23	Chairman, Dakkhola	22049	COMMUNITY BASED	00-8448-00-102-00-001-0-07-00	328667	CBPHCS		
2019080002106	21097	COMMUNITY BASED PRIMARY HEATH CARE	UDA	Islampur	7	Chairman, Islampur	22049	COMMUNITY BASED	00-8448-00-102-00-001-0-07-00	483304	CBPHCS		

Pay Rs. 4279500 Rupees(in words) Forty Two Lakh Seventy Nine Thousand Five Hundred only as transfer.



Assistant/Accountant

Signature of PL/LF/PF/OD Operator

Signature of Joint Signatory

Printed By: DEBARATI DATTA GUPTA

It is certified that the payment advice has been generated out of fund received during the Financial year 2019-20 vide Allotment No. 358 (Sanction) /HF/P/PSD/PHI/HPO-13/11/2018

Dated. 11-07-2019

Page 1 of 1



Director

State Urban Development Agency

Calcutta PAO-III  
Reference Details

For

Xfer -To Operator List For Personal Ledger Account/Local Fund Account/Provident Fund Account/Other Deposit Account

Operator Code : 19

Head of Account : 00-8448-00-120-00-013-0-23-00

Operator Name : DIRECTOR, SUDA

Reference Number : 2019080002101

Net Amount : 2070261

Reference Date : 19/08/2019

Status : Reference Generated

Sl. No.	Scheme Id	Scheme Description	Payee Treasury Code	Payee Treasury Name	Payee Operator Code	Payee Operator Name	Payee Scheme Id	Payee Scheme Description	Amount	Purpose
1	21097	COMMUNITY BASED	MIC	Ghatal	9	Chairman, Chandrakona	22339	CBPHCS	379087 ✓	CBPHCS
2	21097	COMMUNITY BASED	MIC	Ghatal	6	Chairman, Ghatal Municipality	22339	CBPHCS	509493 ✓	CBPHCS
3	21097	COMMUNITY BASED	MIC	Ghatal	10	Chairman, Ranjibapur	22339	CBPHCS	424266 ✓	CBPHCS
4	21097	COMMUNITY BASED	MIC	Ghatal	8	Chairman, Khirpai Municipality	22339	CBPHCS	343521 ✓	CBPHCS
5	21097	COMMUNITY BASED	MIC	Ghatal	7	Chairman, Kharar Municipality	22339	CBPHCS	413894 ✓	CBPHCS

Signature of the Assistant/Accountant

Signature of the Administrator

Printed By : DIPANKAR CHOWDHURY

Printed On : 19/08/2019 2:46 PM

Signature of Joint Signatory

Page 1 of 1

State Urban Development Agency

Calcutta PAO-III  
Reference Details

For

Xfer -To Operator List For Personal Ledger Account/Local Fund Account/Provident Fund Account/Other Deposit Account

Operator Code : 19

Head of Account : 00-8448-00-120-00-013-0-23-00

Operator Name : DIRECTOR, SUDA

Reference Number : 2019080002102

Net Amount : 113719

Reference Date : 19/08/2019

Status : Reference Generated

Sl. No.	Scheme Id	Scheme Description	Payee Treasury Code	Payee Treasury Name	Payee Operator Code	Payee Operator Name	Payee Scheme Id	Payee Scheme Description	Amount	Purpose
1	21097	COMMUNITY BASED	MIB	Contai	2	CHAIRMAN CONTAI	22387	CBPHCS	113719	CBPHCS

Signature of the Assistant/Accountant

Signature of the Administrator

Signature of Joint Signatory

Printed By : DIPANKAR CHOWDHURY

Printed On : 19/08/2019 2:49 PM

Page 1 of 1

Calcutta PAO-III  
Reference Details

For

Xfer -To Operator List For Personal Ledger Account/Local Fund Account/Provident Fund Account/Other Deposit Account

Operator Code : 19 Head of Account : 00-8448-00-120-00-013-0-23-00

Operator Name : DIRECTOR, SUDA

Reference Number : 2019080002103 Net Amount : 404573

Reference Date : 19/08/2019

Status : Reference Generated

Sl. No.	Scheme Id	Scheme Description	Payee Treasury Code	Payee Treasury Name	Payee Operator Code	Payee Operator Name	Payee Scheme Id	Payee Scheme Description	Amount	Purpose
1	21097	COMMUNITY BASED	COA	Cooch Behar-I	12	Chairman, Coochbeh ar	22525	CBPHCS.	404573 ✓	CBPHCS

Signature of the Assistant/Accountant



Signature of the Administrator



Signature of Joint Signatory

Printed By : DIPANKAR CHOWDHURY

Printed On : 19/08/2019 2:51 PM

Page 1 of 1

Director  
Director, Development Branch

Calcutta PAO-III  
Reference Details

For

Xfer -To Operator List For Personal Ledger Account/Local Fund Account/Provident Fund Account/Other Deposit Account

Operator Code : 19

Head of Account : 00-8448-00-120-00-013-0-23-00

Operator Name : DIRECTOR, SUDA

Reference Number : 2019080002105

Net Amount : 880956

Reference Date : 19/08/2019

Status : Reference Generated

Sl. No.	Scheme Id	Scheme Description	Payee Treasury Code	Payee Treasury Name	Payee Operator Code	Payee Operator Name	Payee Scheme Id	Payee Scheme Description	Amount	Purpose
1	21097	COMMUNITY BASED	BUG	Katwa	6	CHAIRMAN KATWA MUNICIPALITY	22003	CBPHCS	505830 ✓	CBPHCS
2	21097	COMMUNITY BASED	BUG	Katwa	7	CHAIRMAN DAINHAT	22003	CBPHCS	375126 ✓	CBPHCS

Signature of the Assistant/Accountant

Signature of the Administrator

Signature of Joint Signatory

Printed By : DIPANKAR CHOWDHURY

Printed On : 19/08/2019 3:09 PM

Page 1 of 1

Calcutta PAO-III  
Reference Details

For

Xfer -To Operator List For Personal Ledger Account/Local Fund Account/Provident Fund Account/Other Deposit Account

Operator Code : 19

Head of Account : 00-8448-00-120-00-013-0-23-00

Operator Name : DIRECTOR, SUDA

Reference Number : 2019080002106

Net Amount : 809991

Reference Date : 19/08/2019

Status : Reference Generated

Sl. No.	Scheme Id	Scheme Description	Payee Treasury Code	Payee Treasury Name	Payee Operator Code	Payee Operator Name	Payee Scheme Id	Payee Scheme Description	Amount	Purpose
1	21097	COMMUNITY BASED	UDA	Islampur	7	Chairman, Islampur Municipality(LF)	22049	COMMUNITY BASED PRIMARY HEALTH CARE SERVICE	483304	CBPHCS
2	21097	COMMUNITY BASED	UDA	Islampur	23	Chairman, Dalkhola Municipality(LF)	22049	COMMUNITY BASED PRIMARY HEALTH CARE SERVICE	326687	CBPHCS

Signature of the Assistant/Accountant



Signature of the Administrator



Signature of Joint Signatory

Printed By : DIPANKAR CHOWDHURY

Printed On : 19/08/2019 3:11 PM

Page 1 of 1



## Calcutta PAO-III

e-Advice For Personal Ledger Account/Local Fund Account/Provident Fund Account/Other Deposit Account

(For Transfer from one Operator to another Operator)

Operator Code : 19

Operator Designation : DIRECTOR, SUDA

Head of Account : 00-8448-00-120-00-013-0-23-00

Local Advice Id : 113

Memo No. : SUDA-87/2006(PT.-III)/16/9704

Local Advice Date : 20/08/2019

Memo Date : 20/08/2019

For use of the Operator

For use of  
Treasury/PAO

Reference No.	Details of Payee Operator		Details of Recipient Operator							Amount(Rs.)	Purpose	Approved	Objected
	Scheme Id of Operator	Scheme Description of Operator	Payee Treasury code	Payee Treasury Name	Operator Code of Payee	Designation of Payee Operator	Scheme Id of Payee Operator	Scheme Description of Payee Operator	Head of Account of the Payee Operator				
2019080002107	21097	COMMUNITY BASED PRIMARY HEATH CARE	MUC	Jangipur	10	DHULYAN MUNICIPALIT	22245	CBPHCS	00-8448-00-102-00-001-0-07-00	360891	CBPHCS		
2019080002107	21097	COMMUNITY BASED PRIMARY HEATH CARE	MUC	Jangipur	9	JANGIPUR MUNICIPALIT	22245	CBPHCS	00-8448-00-102-00-001-0-07-00	415411	CBPHCS		
2019080002108	21097	COMMUNITY BASED PRIMARY HEATH CARE	JAA	Jaipalguri-I	57	Chairman, Dhuggun	22134	CBPHCS	00-8448-00-102-00-001-0-07-00	359414	CBPHCS		
2019080002109	21097	COMMUNITY BASED PRIMARY HEATH CARE	SPC	Diamond Harbour	12	DIAMOND HARBOUR	22267	CBPHCS	00-8448-00-102-00-001-0-07-00	395903	CBPHCS		
2019080002110	21097	COMMUNITY BASED PRIMARY HEATH CARE	COC	Dinhata	5	Chairman Dinhata	22239	CBPHCS	00-8448-00-102-00-001-0-07-00	470804	CBPHCS		
2019080002111	21097	COMMUNITY BASED PRIMARY HEATH CARE	BRA	Birbhum-I	24	CHAIRMAN DUBRAJPUR	22050	CBPHCS	00-8448-00-102-00-001-0-07-00	470804	CBPHCS		
2019080002111	21097	COMMUNITY BASED PRIMARY HEATH CARE	BRA	Birbhum-I	22	CHAIRMAN SURI	22050	CBPHCS	00-8448-00-102-00-001-0-07-00	362059	CBPHCS		
2019080002111	21097	COMMUNITY BASED PRIMARY HEATH CARE	BRA	Birbhum-I	26	CHAIRMAN SAINTHIA	22050	CBPHCS	00-8448-00-102-00-001-0-07-00	363164	CBPHCS		

Pay Rs. 3208150 Rupees(in words) Thirty Two Lakh Eight Thousand One Hundred Fifty only as transfer.

Assignment/Accountant

Signature of PL/LF/PF/OD Operator

Signature of Joint Signatory

Printed By: DEBARATI DATTA GUPTA

It is certified that the payment advice has been generated and fund received during the

Page 1 of 1

Financial year 2019-20

Finance No. 358 (Sudm) / HF/P/PO / P HP / HF 13-13/1/2018

Dated 11-07-2019

Director

State Urban Development Agency

Calcutta PAO-III  
Reference Details

For

Xfer -To Operator List For Personal Ledger Account/Local Fund Account/Provident Fund Account/Other Deposit Account

Operator Code : 19

Head of Account : 00-8448-00-120-00-013-0-23-00

Operator Name : DIRECTOR, SUDA

Reference Number : 20190800002107

Net Amount :

776302

Reference Date : 19/08/2019

Status : Reference Generated

Sl. No.	Scheme Id	Scheme Description	Payee Treasury Code	Payee Treasury Name	Payee Operator Code	Payee Operator Name	Payee Scheme Id	Payee Scheme Description	Amount	Purpose
1	21097	COMMUNITY BASED	MUC	Jangipur	9	JANGIPUR MUNICIPALITY	22245	CBPHCS	415411	CBPHCS
2	21097	COMMUNITY BASED	MUC	Jangipur	10	DHULIYAN MUNICIPALITY	22245	CBPHCS	360891	CBPHCS

Signature of the Assistant/Accountant



Printed By : DIPANKAR CHOWDHURY

Signature of the Administrator

Printed On : 19/08/2019 3:17 PM

Signature of Joint Signatory

Director



State Urban Development Agency

Calcutta PAO-III  
Reference Details

For

Xfer -To Operator List For Personal Ledger Account/Local Fund Account/Provident Fund Account/Other Deposit Account

Operator Code : 19

Head of Account : 00-8448-00-120-00-013-0-23-00

Operator Name : DIRECTOR, SUDA

Reference Number : 2019080002108

Net Amount : 369414

Reference Date : 19/08/2019

Status : Reference Generated

Sl. No.	Scheme Id	Scheme Description	Payee Treasury Code	Payee Treasury Name	Payee Operator Code	Payee Operator Name	Payee Scheme Id	Payee Scheme Description	Amount	Purpose
1	21097	COMMUNITY BASED	JAA	Jalpaiguri-1	57	Chairman, Dhupguri Municipality.	22134	CBPHCS	369414	CBPHCS



Signature of the Assistant/Accountant

Printed By : DIPANKAR CHOWDHURY

Signature of the Administrator

Printed On : 19/08/2019 3:20 PM

  
Director  
State Urban Development Corporation

Signature of Joint Signatory

Calcutta PAO-III  
Reference Details

For

Xfer - To Operator List For Personal Ledger Account/Local Fund Account/Provident Fund Account/Other Deposit Account

Operator Code : 19

Head of Account : 00-8448-00-120-00-013-0-23-00

Operator Name : DIRECTOR, SUDA

Reference Number : 20190800002109

Net Amount : 395603

Reference Date : 19/08/2019

Status : Reference Generated

Sl. No.	Scheme Id	Scheme Description	Payee Treasury Code	Payee Treasury Name	Payee Operator Code	Payee Operator Name	Payee Scheme Id	Payee Scheme Description	Amount	Purpose
1	21097	COMMUNITY BASED	SPC	Diamond Harbour	12	DIAMOND HARBOUR	22267	CBPHCS	395603	CBPHCS

Signature of the Assistant/Accountant



Printed By : DIPANKAR CHOWDHURY

Signature of the Administrator

Printed On : 19/08/2019 3:21 PM

Signature of Joint Signatory



Director

State Urban Development Corporation

Calcutta PAO-III  
Reference Details

For

Xier -To Operator List For Personal Ledger Account/Local Fund Account/Provident Fund Account/Other Deposit Account

Operator Code : 19

Head of Account : 00-8448-00-120-00-013-0-23-00

Operator Name : DIRECTOR, SUDA

Reference Number : 2019080002110

Net Amount :

470804

Reference Date : 19/08/2019

Status : Reference Generated

Sl. No.	Scheme Id	Scheme Description	Payee Treasury Code	Payee Treasury Name	Payee Operator Code	Payee Operator Name	Payee Scheme Id	Payee Scheme Description	Amount	Purpose
1	21097	COMMUNITY BASED	COC	Dinhata	5	Chairman Dinhata Municipality.	22239	CBPHCS	470804	CBPHCS

Signature of the Assistant/Accountant



Printed By : DIPANKAR CHOWDHURY

Signature of the Administrator

Printed On : 19/08/2019 3:25 PM

Signature of Joint Signatory

Page 1 of 1

  
Director  
Urban Development Agency

Calcutta PAO-III  
Reference Details

For

Xfer -To Operator List For Personal Ledger Account/Local Fund Account/Provident Fund Account/Other Deposit Account

Operator Code : 19

Head of Account : 00-8448-00-120-00-013-0-23-00

Operator Name : DIRECTOR, SUDA

Reference Number : 2019080002111

Net Amount : 1196027

Reference Date : 19/08/2019

Status : Reference Generated

Sl. No.	Scheme Id	Scheme Description	Payee Treasury Code	Payee Treasury Name	Payee Operator Code	Payee Operator Name	Payee Scheme Id	Payee Scheme Description	Amount	Purpose
1	21097	COMMUNITY BASED	BRA	Birbhūm-I	24	CHAIRMAN DUBRAJPUR	22050	CBPHCS	470804	CBPHCS
2	21097	COMMUNITY BASED	BRA	Birbhūm-I	26	CHAIRMAN SAINTHIA	22050	CBPHCS	363164	CBPHCS
3	21097	COMMUNITY BASED	BRA	Birbhūm-I	22	CHAIRMAN SURI MUNICIPALITY(LF)	22050	CBPHCS	362059	CBPHCS

Signature of the Assistant/Accountant

Signature of the Administrator

Signature of Joint Signatory

Printed By : DIPANKAR CHOWDHURY

Printed On : 19/08/2019 3:28 PM

Operator Code : 19

Operator Designation : DIRECTOR, SUDA

Head of Account : 00-8448-00-120-00-013-0-23-00

Local Advice Id : 114

Memo No. : SUDA-67/2006(PT.-III)/16/9705

Local Advice Date : 20/08/2019

Memo Date : 20/08/2019

For use of the Operator												For use of Treasury/PAO	
Reference No.	Details of Payee Operator		Details of Recipient Operator							Amount(Rs.)	Purpose	Approved	Objected
	Scheme Id of Operator	Scheme Description of Operator	Payee Treasury code	Payee Treasury Name	Operator Code of Payee	Designation of Payee Operator	Scheme Id of Payee Operator	Scheme Description of Payee Operator	Head of Account of the Payee Operator				
2019080002112	21097	COMMUNITY BASED PRIMARY HEATH CARE	PMD	Egra	3	CHAIRMAN EGRA	22196	CBPHCS	00-8448-00-102-00-001-0-07-00	466566	CBPHCS		
2019080002113	21097	COMMUNITY BASED PRIMARY HEATH CARE	DDC	Gengarampu	5	CHAIRMAN, GANGARAMP	22036	CBPHCH	00-8448-00-102-00-001-0-07-00	525116	CBPHCS		
2019080002114	21097	COMMUNITY BASED PRIMARY HEATH CARE	BUA	Burdwan-I	18	CHAIRMAN, G USHKARA	22362	CBPHCS(2018-19)	00-8448-00-102-00-001-0-07-00	355039	CBPHCS		
2019080002114	21097	COMMUNITY BASED PRIMARY HEATH CARE	BUA	Burdwan-I	19	CHAIRMAN, MEMARI	22362	CBPHCS(2018-19)	00-8448-00-102-00-001-0-07-00	150330	CBPHCS		
2019080002116	21097	COMMUNITY BASED PRIMARY HEATH CARE	MID	Haldia	20	CHAIR PERSON	22013	CBPHCS	00-8448-00-102-00-001-0-07-00	753482	CBPHCS		
2019080002118	21097	COMMUNITY BASED PRIMARY HEATH CARE	COE	Mekhliganj	3	CHAIRMAN, HALDIBARI	22224	CBPHCS	00-8448-00-102-00-001-0-07-00	412307	CBPHCS		
2019080002118	21097	COMMUNITY BASED PRIMARY HEATH CARE	COE	Mekhliganj	2	CHAIRMAN, MEKHLIGANJ	22224	CBPHCS	00-8448-00-102-00-001-0-07-00	221521	CBPHCS		

Pay Rs. 2924383 Rupees(in words) Twenty Nine Lakh Twenty Four Thousand Three Hundred Eighty Three only as transfer.

Assistant/Accountant

Signature of PULF/PFI/OD Operator

Signature of Joint Signatory

Printed By: DEBARATI DATTA GUPTA

It is certified that the payment advice has been generated out of fund received during the

Page 1 of 1

Financial year 19...-20...vide Allotment No. 358 (Sanctn)/HT/P/PAJ/PHP/HFW-13/1/2018

Dated... 20-08-2019

Director  
State Urban Development Agency

Calcutta PAO-III  
Reference Details

For

Xfer -To Operator List For Personal Ledger Account/Local Fund Account/Provident Fund Account/Other Deposit Account

Operator Code : 19

Head of Account : 00-8448-00-120-00-013-0-23-00

Operator Name : DIRECTOR, SUDA

Reference Number : 2019080002112

Net Amount : 486586

Reference Date : 19/08/2019

Status : Reference Generated

Sl. No.	Scheme Id	Scheme Description	Payee Treasury Code	Payee Treasury Name	Payee Operator Code	Payee Operator Name	Payee Scheme Id	Payee Scheme Description	Amount	Purpose
1	21097	COMMUNITY BASED	PMD	Egra	3	CHAIRMAN EGRA MUNICIPALITY	22196	CBPHCS	486586 ✓	CBPHCS

Signature of the Assistant/Accountant



Signature of the Administrator



Signature of Joint Signatory

Printed By : DIPANKAR CHOWDHURY

Printed On : 19/08/2019 3:34 PM

Director  
State Urban Development Agency

Page 1 of 1



Calcutta PAO-III  
Reference Details

For  
Xier -To Operator List For Personal Ledger Account/Local Fund Account/Provident Fund Account/Other Deposit Account

Operator Code : 19

Operator Name : DIRECTOR, SUDA

Reference Number : 2019080002113

Reference Date : 19/08/2019

Status : Reference Generated

Head of Account : 00-8448-00-120-00-013-0-23-00

Net Amount : 525118

Sl. No.	Scheme Id	Scheme Description	Payee Treasury Code	Payee Treasury Name	Payee Operator Code	Payee Operator Name	Payee Scheme Id	Payee Scheme Description	Amount	Purpose
1	21097	COMMUNITY BASED	DDC	Gangarampur	5	CHAIRMAN, GANGARAMPUR	22036	CBPHCH	525118 ✓	CBPHCS

Signature of the Assistant/Accountant

Printed By : DIPANKAR CHOWDHURY

Signature of the Administrator

Printed On : 19/08/2019 3:38 PM

Signature of Joint Signatory

Director  
State Urban Development Agency

Calcutta PAO-III  
Reference Details

For

Xfer - To Operator List For Personal Ledger Account/Local Fund Account/Provident Fund Account/Other Deposit Account

Operator Code : 19

Head of Account : 00-8448-00-120-00-013-0-23-00

Operator Name : DIRECTOR, SUDA

Reference Number : 2019080002114

Net Amount :

515369

Reference Date : 19/08/2019

Status : Reference Generated

Sl. No.	Scheme Id	Scheme Description	Payee Treasury Code	Payee Treasury Name	Payee Operator Code	Payee Operator Name	Payee Scheme Id	Payee Scheme Description	Amount	Purpose
1	21097	COMMUNITY BASED	BUA	Burdwan-I	19	CHAIRMAN, MEMARI	22362	CBPHCS(2018-19)	150330	CBPHCS
2	21097	COMMUNITY BASED	BUA	Burdwan-I	18	CHAIRMAN, GUSHK ARA	22362	CBPHCS(2018-19)	365039	CBPHCS

Signature of the Assistant/Accountant



Printed By : DIPANKAR CHOWDHURY

Signature of the Administrator

Printed On : 19/08/2019 3:40 PM

Signature of Joint Signatory



Director

State (Human) Development Agency

Calcutta PAO-III  
Reference Details

For

Xier -To Operator List For Personal Ledger Account/Local Fund Account/Provident Fund Account/Other Deposit Account

Operator Code : 19

Head of Account : 00-8448-00-120-00-013-0-23-00

Operator Name : DIRECTOR, SUDA

Net Amount : 763482

Reference Number : 2019080002116

Reference Date : 19/08/2019

Status : Reference Generated

Sl. No.	Scheme Id	Scheme Description	Payee Treasury Code	Payee Treasury Name	Payee Operator Code	Payee Operator Name	Payee Scheme Id	Payee Scheme Description	Amount	Purpose
1	21097	COMMUNITY BASED	MID	Halidia	20	CHAIR PERSON HALDIA	22013	CBPHCS	763482	CBPHCS

Signature of the Assistant/Accountant



Signature of the Administrator



Printed By : DIPANKAR CHOWDHURY

Printed On : 19/08/2019 3:44 PM

Signature of Joint Signatory

Director  
Calcutta PAO-III

Calcutta PAO-III  
Reference Details

For

Xfer - To Operator List For Personal Ledger Account/Local Fund Account/Provident Fund Account/Other Deposit Account

Operator Code : 19

Head of Account : 00-8448-00-120-00-013-0-23-00

Operator Name : DIRECTOR, SUDA

Reference Number : 2019080002118

Net Amount :

633828

Reference Date : 19/08/2019

Status : Reference Generated

Sl. No.	Scheme Id	Scheme Description	Payee Treasury Code	Payee Treasury Name	Payee Operator Code	Payee Operator Name	Payee Scheme Id	Payee Scheme Description	Amount	Purpose
1	21097	COMMUNITY BASED	COE	Mekhliganj	2	CHAIRMAN, MEKHLIGANJ	22224	CBPHCS	221521	CBPHCS
2	21097	COMMUNITY BASED	COE	Mekhliganj	3	CHAIRMAN, HALDIBARI	22224	CBPHCS	412307	CBPHCS

Signature of the Assistant/Accountant

Printed By : DIPANKAR CHOWDHURY

Signature of the Administrator

Printed On : 19/08/2019 3:55 PM

Signature of Joint Signatory

Page 1 of 1

Operator Code : 19

Operator Designation : DIRECTOR, SUDA

Head of Account : 00-8448-00-120-00-013-0-23-00

Local Advice Id : 115

Memo No. : SUDA-67/2006(PT.-III)/16/9706

Local Advice Date : 20/08/2019

Memo Date : 20/08/2019

For use of the Operator											For use of Treasury/PAO		
Reference No.	Details of Payee Operator		Details of Recipient Operator							Amount(Rs.)	Purpose	Approved	Objected
	Scheme Id of Operator	Scheme Description of Operator	Payee Treasury code	Payee Treasury Name	Operator Code of Payee	Designation of Payee Operator	Scheme Id of Payee Operator	Scheme Description of Payee Operator	Head of Account of the Payee Operator				
2019080002119	21097	COMMUNITY BASED PRIMARY HEATH CARE	SPD	Barulpur	7	CHAIRMAN, J OYNAGAR	22161	CBPHCS	00-8448-00-102-00-001-0-07-00	461766	CBPHCS		
2019080002122	21097	COMMUNITY BASED PRIMARY HEATH CARE	PUC	Jhalda	1	CHAIRMAN, JHALDA	22031	CBPHCS	00-8448-00-102-00-001-0-07-00	436316	CBPHCS		
2019080002123	21097	COMMUNITY BASED PRIMARY HEATH CARE	MIE	Jhargram	9	CHAIRMAN, JHARGRAM	22106	CBPHCS	00-8448-00-102-00-001-0-07-00	186456	CBPHCS		
2019080002124	21097	COMMUNITY BASED PRIMARY HEATH CARE	MUE	Lalbagh	9	CHAIRMAN, JIAGANJ	22312	CBPHCS	00-8448-00-102-00-001-0-07-00	543607	CBPHCS		
2019080002124	21097	COMMUNITY BASED PRIMARY HEATH CARE	MUE	Lalbagh	7	CHAIRMAN, MURSHIDABA	22312	CBPHCS	00-8448-00-102-00-001-0-07-00	352384	CBPHCS		
2019080002125	21097	COMMUNITY BASED PRIMARY HEATH CARE	UDB	Raigunj-I	14	Chairman, Kallaganj	22207	CBPHCS	00-8448-00-102-00-001-0-07-00	483280	CBPHCS		

Pay Rs. 2504009 Rupees(in words) Twenty Five Lakh Four Thousand Nine only as transfer.

Assistant/Accountant

Signature of PULF/PF/OD Operator

Signature of Joint Signatory

Printed By: DEBARATI DATTA GUPTA

It is certified that the payment advice has been generated if funds received during the

Final No. 358(Sanction)/HF/P/PLS/PHF/HPO-13/1/2018  
Dated... 11-02-2019Director  
State Urban Development Agency

Calcutta PAO-III  
Reference Details

For

Xfer -To Operator List For Personal Ledger Account/Local Fund Account/Provident Fund Account/Other Deposit Account

Operator Code : 19

Head of Account : 00-8448-00-120-00-013-0-23-00

Operator Name : DIRECTOR, SUDA

Net Amount : 461766

Reference Number : 2019080002119

Reference Date : 19/08/2019

Status : Reference Generated

Sl. No.	Scheme Id	Scheme Description	Payee Treasury Code	Payee Treasury Name	Payee Operator Code	Payee Operator Name	Payee Scheme Id	Payee Scheme Description	Amount	Purpose
1	21097	COMMUNITY BASED	SPD	Barulpur	7	CHAIRMAN.JOYNA GAR	22181	CBPHCS	461766	CBPHCS

Signature of the Assistant/Accountant



Printed By : DIPANKAR CHOWDHURY

Signature of the Administrator

Printed On : 19/08/2019 4:01 PM

Signature of Joint Signatory



State Urban Development Agency

Calcutta PAO-III  
Reference Details

For

Xier -To Operator List For Personal Ledger Account/Local Fund Account/Provident Fund Account/Other Deposit Account

Operator Code : 19

Head of Account : 00-8448-00-120-00-013-0-23-00

Operator Name : DIRECTOR, SUDA

Reference Number : 2019080002122

Net Amount :

436316

Reference Date : 19/08/2019

Status : Reference Generated

Sl. No.	Scheme Id	Scheme Description	Payee Treasury Code	Payee Treasury Name	Payee Operator Code	Payee Operator Name	Payee Scheme Id	Payee Scheme Description	Amount	Pu
1	21097	COMMUNITY BASED	PUC	Jhalda	1	CHAIRMAN, JHALDA	22031	CBPHCS	436316	CB

Signature of the Assistant/Accountant



Printed By : DIPANKAR CHOWDHURY

Signature of the Administrator

Printed On : 19/08/2019 4:14 PM

Signature of Jc

Page

Calcutta PAO-III  
Reference Details

For

Xfer - To Operator List For Personal Ledger Account/Local Fund Account/Provident Fund Account/Other Deposit Account

Operator Code : 19

Head of Account : 00-8448-00-120-00-013-0-23-00

Operator Name : DIRECTOR, SUDA

Net Amount : 186456

Reference Number : 20190800002123

Reference Date : 19/08/2019

Status : Reference Generated

Sl. No.	Scheme Id	Scheme Description	Payee Treasury Code	Payee Treasury Name	Payee Operator Code	Payee Operator Name	Payee Scheme Id	Payee Scheme Description	Amount	Purpose
1	21097	COMMUNITY BASED	MIE	Jhargram	9	CHAIRMAN, JHARGRAM	22106	CBPHCS	186456 ✓	CBPHCS

Signature of the Assistant/Accountant



Printed By : DIPANKAR CHOWDHURY

Signature of the Administrator

Printed On : 19/08/2019 4:16 PM

Signature of Joint Signatory



Director  
Human Development Agency





# LASERJET PROFESSIONAL P1100 Printer Series

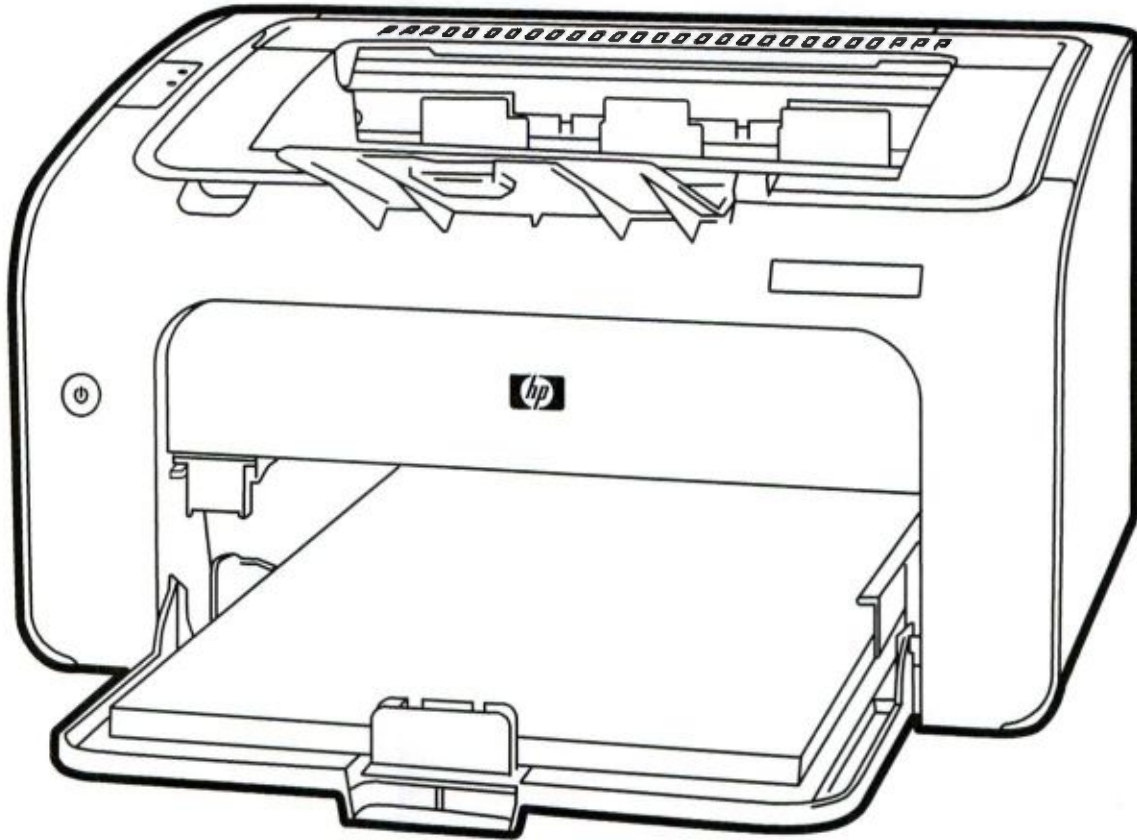

## Simple and Trustworthy

Effortless setup—no CD installation required—using HP Smart Install.<sup>1</sup> Print up to 19 ppm on multiple paper sizes and types—card stock, transparencies and more.

## Performance and Value

Get bold, crisp text and sharp images with HP FastRes 1200 and Original HP toner.

## Environmental Leadership

Reduce your impact on the environment with power-saving features like Instant-on Technology<sup>2</sup> and HP Auto-Off/Auto-On Technology.



Install<sup>1</sup>



up to  
19 PPM/18 PPM



Technology<sup>2</sup>



Technology

<sup>1</sup> For Windows only

<sup>2</sup> First page out in less than 8.5 seconds

Calcutta PAO-III  
Reference Details

For

Xfer - To Operator List For Personal Ledger Account/Local Fund Account/Provident Fund Account/Other Deposit Account

Operator Code : 19

Head of Account : 00-8448-00-120-00-013-0-23-00

Operator Name : DIRECTOR, SUDA

Reference Number : 20190800002124

Net Amount : 936191

Reference Date : 19/08/2019

Status : Reference Generated

Sl. No.	Scheme Id	Scheme Description	Payee Treasury Code	Payee Treasury Name	Payee Operator Code	Payee Operator Name	Payee Scheme Id	Payee Scheme Description	Amount	Purpose
1	21097	COMMUNITY BASED	MUE	Labagh	7	CHAIRMAN, MURSHIDABAD	22312	CBPHCS	392384	CBPHCS
2	21097	COMMUNITY BASED	MUE	Labagh	9	CHAIRMAN, JAGANNJ-	22312	CBPHCS	543807	CBPHCS

Signature of the Assistant/Accountant



Signature of the Administrator



Signature of Joint Signatory

Printed By : DIPANKAR CHOWDHURY

Printed On : 19/08/2019 4:18 PM

Page 1 of 1

Director  
Development Agency

Calcutta PAO-III  
Reference Details

For

Xfer - To Operator List For Personal Ledger Account/Local Fund Account/Provident Fund Account/Other Deposit Account

Operator Code : 19

Head of Account : 00-8448-00-120-00-013-0-23-00

Operator Name : DIRECTOR, SUDA

Reference Number : 2019080002125

Net Amount : 483280

Reference Date : 19/08/2019

Status : Reference Generated

Sl. No.	Scheme Id	Scheme Description	Payee Treasury Code	Payee Treasury Name	Payee Operator Code	Payee Operator Name	Payee Scheme Id	Payee Scheme Description	Amount	Purpose
1	21097	COMMUNITY BASED	UDB	Raigunj-I	14	Chairman, Kaliaganj Municipality, -LF A/C	22207	CBPHCS	483280	CBPHCS

Signature of the Assistant/Accountant

Printed By : DIPANKAR CHOWDHURY

Signature of the Administrator

Printed On : 19/08/2019 4:20 PM

Signature of Joint Signatory

Page 1 of 1

# LASERJET PROFESSIONAL P1100 Printer Series

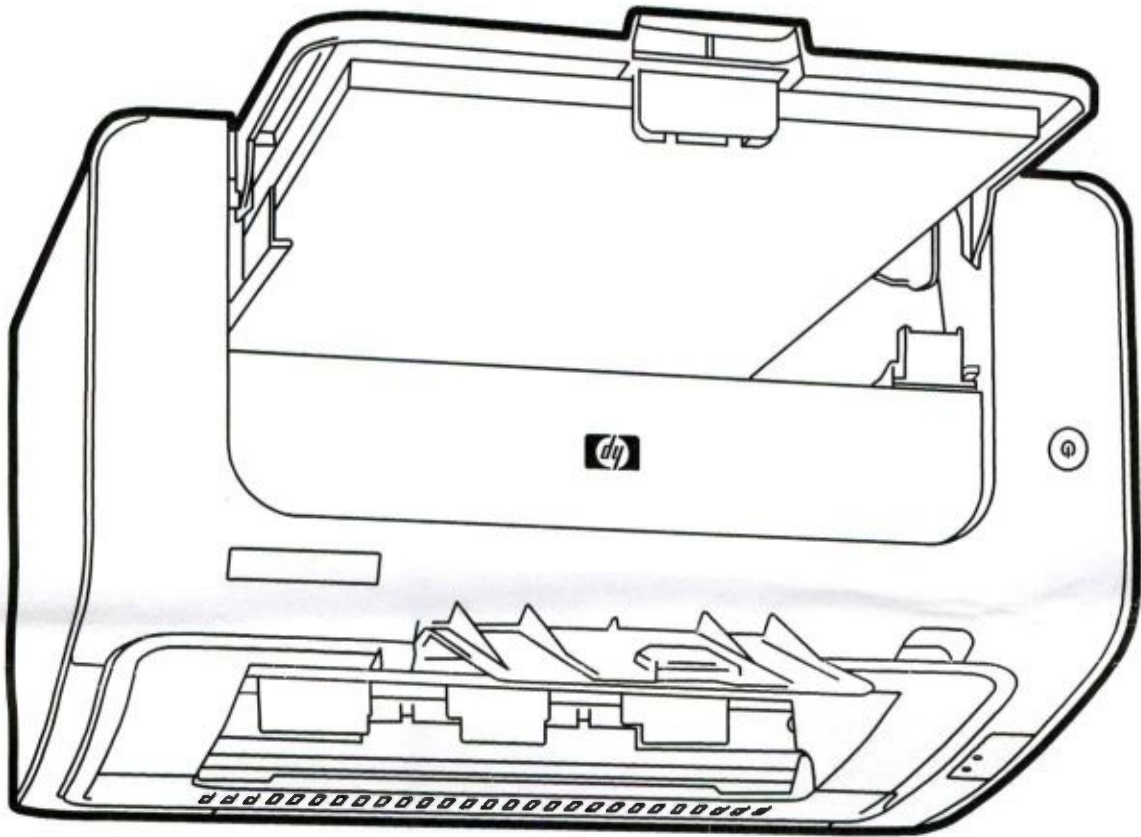

## Simple and Trustworthy

Effortless setup—no CD installation required—using HP Smart Install.<sup>1</sup> Print up to 19 ppm on multiple paper sizes and types—card stock, transparencies and more.

## Performance and Value

Get bold, crisp text and sharp images with HP FastRes 1200 and Original HP toner.

## Environmental Leadership

Reduce your impact on the environment with power-saving features like Instant-On Technology<sup>2</sup> and HP Auto-Off/Auto-On Technology.



Smart Install<sup>1</sup>

19 PPM/18 PPM



Print



Instant-On Technology<sup>2</sup>



Auto-Off/Auto-On Technology

<sup>1</sup> For Windows only  
<sup>2</sup> First page out in less than 8.5 seconds

Operator Code : 19

Operator Designation : DIRECTOR, SUDA

Head of Account : 00-8448-00-120-00-013-0-23-00

Local Advice Id : 116

Memo No. : SUDA-67/2006(PT.-III)/16/9707

Local Advice Date : 20/08/2019

Memo Date : 20/08/2019

For use of the Operator												For use of Treasury/PAO	
Reference No.	Details of Payee Operator			Details of Recipient Operator						Amount(Rs.)	Purpose	Approved	Objected
	Scheme Id of Operator	Scheme Description of Operator	Payee Treasury code	Payee Treasury Name	Operator Code of Payee	Designation of Payee Operator	Scheme Id of Payee Operator	Scheme Description of Payee Operator	Head of Account of the Payee Operator				
20190800002126	21097	COMMUNITY BASED PRIMARY HEATH CARE	DAC	Kalimpong	4	Chairman, Kalimpong	22140	CBPHCS	00-8448-00-102-00-001-0-07-00	338635	CBPHCS		
20190800002127	21097	COMMUNITY BASED PRIMARY HEATH CARE	BUF	Kalna	7	CHAIRMAN KALNA	21994	CBPHCS	00-8448-00-102-00-001-0-07-00	473399	CBPHCS		
20190800002128	21097	COMMUNITY BASED PRIMARY HEATH CARE	MUD	Kandi	11	CHAIRMAN, K ANDI	22535	CBPHCS	00-8448-00-102-00-001-0-07-00	270786	CBPHCS		
20190800002130	21097	COMMUNITY BASED PRIMARY HEATH CARE	NAA	KrishnaNaga r-I	3	Nabadwip Municipality	22149	CBPHCS( COMMUNITY	00-8448-00-102-00-001-0-07-00	720886	CBPHCS		
20190800002130	21097	COMMUNITY BASED PRIMARY HEATH CARE	NAA	KrishnaNaga r-I	13	Chairman, Kris hnagar	22149	CBPHCS( COMMUNITY	00-8448-00-102-00-001-0-07-00	627217	CBPHCS		
20190800002131	21097	COMMUNITY BASED PRIMARY HEATH CARE	DAB	Kurseong	11	Chairman, Kurseong	22527	CBPHCS(HR W)	00-8448-00-102-00-001-0-07-00	339536	CBPHCS		

Pay Rs. 2770459 Rupees(in words) Twenty Seven Lakh Seventy Thousand Four Hundred Fifty Nine only as transfer.



Assistant/Accountant

Signature of PL/LF/PF/OD Operator

Signature of Joint Signatory

Printed By: DEBARATI DATTA GUPTA

It is certified that the payment advice has been generated and fund received during the

Page 1 of 1

Finance No. 358 (Sanction) / HF / P / PRD / PHP / HF No-13 / 1 / 2018  
 Dated. 11-07-2019



State Urban Development Agency

Calcutta PAO-III  
Reference Details

For

Xier -To Operator List For Personal Ledger Account/Local Fund Account/Provident Fund Account/Other Deposit Account

Operator Code : 19

Head of Account : 00-8448-00-120-00-013-0-23-00

Operator Name : DIRECTOR, SUDA

Reference Number : 20190800002126

Net Amount : 338635

Reference Date : 19/08/2019

Status : Reference Generated

Sl. No.	Scheme Id	Scheme Description	Payee Treasury Code	Payee Treasury Name	Payee Operator Code	Payee Operator Name	Payee Scheme Id	Payee Scheme Description	Amount	Purpose
1	21097	COMMUNITY BASED	DAC	Kalimpong	4	Chairman, Kalimpong	22140	CBPHCS	338635 ✓	CBPHCS

Signature of the Assistant/Accountant



Printed By : DIPANKAR CHOWDHURY

Signature of the Administrator

Printed On : 19/08/2019 4:21 PM

Signature of Joint Signatory



Calcutta PAO-III  
Reference Details

For

Xier - To Operator List For Personal Ledger Account/Local Fund Account/Provident Fund Account/Other Deposit Account

Operator Code : 19

Head of Account : 00-8448-00-120-00-013-0-23-00

Operator Name : DIRECTOR, SUDA

Reference Number : 20190800002127

Net Amount :

473399

Reference Date : 19/08/2019

Status : Reference Generated

Sl. No.	Scheme Id	Scheme Description	Payee Treasury Code	Payee Treasury Name	Payee Operator Code	Payee Operator Name	Payee Scheme Id	Payee Scheme Description	Amount	Purpose
1	21097	COMMUNITY BASED	BUF	Kalna	7	CHAIRMAN KALNA MUNICIPALITY	21994	CBPHCS	473399	CBPHCS

Signature of the Assistant/Accountant

Signature of the Administrator

Signature of Joint Signatory

Printed By : DIPANKAR CHOWDHURY

Printed On : 19/08/2019 4:23 PM

Page 1 of 1

Director  
K.P.P.

Calcutta Urban Development Authority

Calcutta PAO-III  
Reference Details

For

Xfer - To Operator List For Personal Ledger Account/Local Fund Account/Provident Fund Account/Other Deposit Account

Operator Code : 19

Head of Account : 00-8448-00-120-00-013-0-23-00

Operator Name : DIRECTOR, SUDA

Reference Number : 2019080002128

Net Amount :

270786

Reference Date : 19/08/2019

Status : Reference Generated

Sl. No.	Scheme Id	Scheme Description	Payee Treasury Code	Payee Treasury Name	Payee Operator Code	Payee Operator Name	Payee Scheme Id	Payee Scheme Description	Amount	Purpose
1	21097	COMMUNITY BASED	MUD	Kandi	11	CHAIRMAN KANDI MUNICIPALITY(LF)	22535	CBPHCS	270786 ✓	CBPHCS

Signature of the Assistant/Accountant

Signature of the Administrator

Signature of Joint Signatory

Printed By : DIPANKAR CHOWDHURY

Printed On : 19/08/2019 4:25 PM

Page 1 of 1

*[Handwritten signature and stamp]*



Calcutta PAO-III  
Reference Details  
For

Xier -To Operator List For Personal Ledger Account/Local Fund Account/Provident Fund Account/Other Deposit Account

Operator Code : 19

Head of Account : 00-8448-00-120-00-013-0-23-00

Operator Name : DIRECTOR, SUDA

Reference Number : 20190800002130

Net Amount :

1348103

Reference Date : 19/08/2019

Status : Reference Generated

Sl. No.	Scheme Id	Scheme Description	Payee Treasury Code	Payee Treasury Name	Payee Operator Code	Payee Operator Name	Payee Scheme Id	Payee Scheme Description	Amount	Purpose
1	21097	COMMUNITY BASED	NAA	KrishnaNag ar-I	3	Nabadwip Municipality	22149	CBPHCS( COMMUNITY BASED PRIMARY HEALTH CARE	720886	CBPHCS
2	21097	COMMUNITY BASED	NAA	KrishnaNag ar-I	13	Chairman, Krishnaga	22149	CBPHCS( COMMUNITY BASED PRIMARY HEALTH CARE	627217	CBPHCS

Signature of the Assistant/Accountant

Signature of the Administrator

Signature of Joint Signatory

Printed By : DIPANKAR CHOWDHURY

Printed On : 19/08/2019 4:27 PM

Page 1 of 1

Calcutta PAO-III  
Reference Details

For

Xfer -To Operator List For Personal Ledger Account/Local Fund Account/Provident Fund Account/Other Deposit Account

Operator Code : 19

Head of Account : 00-8448-00-120-00-013-0-23-00

Operator Name : DIRECTOR, SUDA

Reference Number : 20190800002131

Net Amount : 339536

Reference Date : 19/08/2019

Status : Reference Generated

Sl. No.	Scheme Id	Scheme Description	Payee Treasury Code	Payee Treasury Name	Payee Operator Code	Payee Operator Name	Payee Scheme Id	Payee Scheme Description	Amount	Purpose
1	21097	COMMUNITY BASED	DAB	Kurseong	11	Chairman, Kurseong Municipality	22527	CBPHCS(HHW)	339536	CBPHCS

Signature of the Assistant/Accountant



Printed By : DIPANKAR CHOWDHURY

Signature of the Administrator

Printed On : 19/08/2019 4:29 PM

Signature of Joint Signatory



# LASERJET PROFESSIONAL P1100 Printer Series

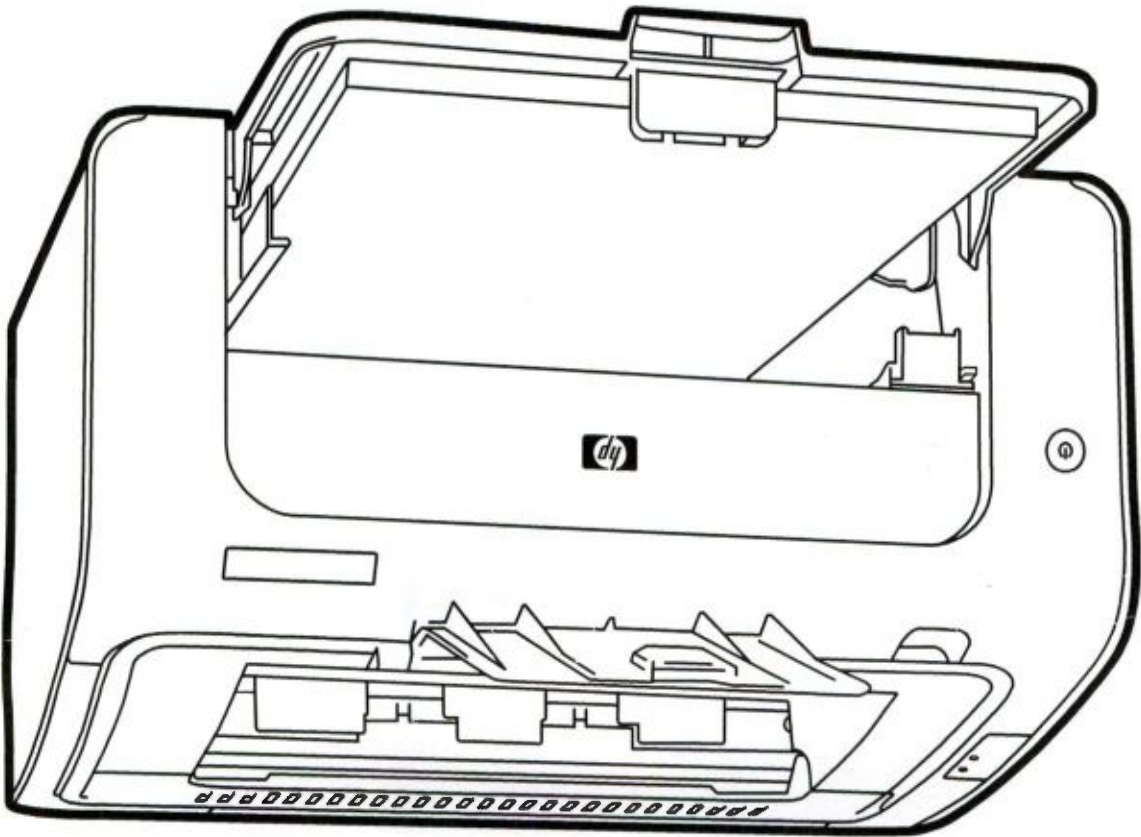

## Simple and Trustworthy

Effortless setup—no CD installation required—using HP Smart Install.<sup>1</sup> Print up to 19 ppm on multiple paper sizes and types—card stock, transparencies and more.

## Performance and Value

Get bold, crisp text and sharp images with HP FastRes 1200 and Original HP toner.

## Environmental Leadership

Reduce your impact on the environment with power-saving features like Instant-on Technology<sup>2</sup> and HP Auto-Off/Auto-On Technology.



<sup>1</sup> For Windows only  
<sup>2</sup> First page out in less than 8.5 seconds

Operator Code : 19

Operator Designation : DIRECTOR, SUDA

Head of Account : 00-8448-00-120-00-013-0-23-00

Local Advice Id : 117

Memo No. : SUDA-87/2006(PT.-III)/16/9708

Local Advice Date : 20/08/2019

Memo Date : 20/08/2019

For use of the Operator												For use of Treasury/PAO		
Reference No.	Details of Payee Operator			Details of Recipient Operator							Amount(Rs.)	Purpose	Approved	Objected
	Scheme Id of Operator	Scheme Description of Operator	Payee Treasury code	Payee Treasury Name	Operator Code of Payee	Designation of Payee Operator	Scheme Id of Payee Operator	Scheme Description of Payee Operator	Head of Account of the Payee Operator					
2019080002133	21097	COMMUNITY BASED PRIMARY HEATH CARE	JAD	Mal	4	CHAIRMAN, MAL	22214	CBPHCS	00-8448-00-102-00-001-0-07-00	443365	CBPHCS			
2019080002134	21097	COMMUNITY BASED PRIMARY HEATH CARE	COD	Mathabhanga	14	Chairman, Mathabhanga	22133	CBPHCS	00-8448-00-102-00-001-0-07-00	361888	CBPHCS			
2019080002136	21097	COMMUNITY BASED PRIMARY HEATH CARE	MIA	Midnapore	25	CHAIRMAN MIDNAPORE	22304	CBPHCS	00-8448-00-102-00-001-0-07-00	572771	CBPHCS			
2019080002138	21097	COMMUNITY BASED PRIMARY HEATH CARE	BRC	Rampurhat	11	CHAIRMAN, NALHATI	22086	CBPHCS	00-8448-00-102-00-001-0-07-00	423667	CBPHCS			
2019080002138	21097	COMMUNITY BASED PRIMARY HEATH CARE	BRC	Rampurhat	10	CHAIRMAN, RAMPURHAT	22086	CBPHCS	00-8448-00-102-00-001-0-07-00	377539	CBPHCS			
2019080002140	21097	COMMUNITY BASED PRIMARY HEATH CARE	MDB	Malda-II	3	CHAIRMAN, OLD MALDA	22176	CBPHCS	00-8448-00-102-00-001-0-07-00	413140	CBPHCS			

Pay Rs. 2612370 Rupees(in words) Twenty Six Lakh Twelve Thousand Three Hundred Seventy only as transfer.



Assistant/Accountant

Signature of PL/LF/PF/OD Operator

Signature of Joint Signatory

Printed By: DEBARATI DATTA GUPTA

It is certified that the payment advice has been generated out of fund received during the Page 1 of 1

Financial year 2019-20 vide Allotment  
 No. 358 (Jointly) / HIF/P/PLD/PHP/HRS-13/1/2018  
 Dated 11-07-2019  
 Director  
 State Urban Development Agency

Calcutta PAO-III  
Reference Details

For

Xfer -To Operator List For Personal Ledger Account/Local Fund Account/Provident Fund Account/Other Deposit Account

Operator Code : 19

Head of Account : 00-8448-00-120-00-013-0-23-00

Operator Name : DIRECTOR, SUDA

Reference Number : 20190800002133

Net Amount : 443365

Reference Date : 19/08/2019

Status : Reference Generated

Sl. No.	Scheme Id	Scheme Description	Payee Treasury Code	Payee Treasury Name	Payee Operator Code	Payee Operator Name	Payee Scheme Id	Payee Scheme Description	Amount	Purpose
1	21097	COMMUNITY BASED	JAD	Mal	4	CHAIRMAN, MAL MUNICIPALITY	22214	CBPHCS	443365 X	CBPHCS

Signature of the Assistant/Accountant

Signature of the Administrator

Printed By : DIPANKAR CHOWDHURY

Printed On : 19/08/2019 4:30 PM

Signature of Joint Signatory

Director

State Urban Development Corporation

Calcutta PAO-III  
Reference Details

For

Xier -To Operator List For Personal Ledger Account/Local Fund Account/Provident Fund Account/Other Deposit Account

Operator Code : 19

Head of Account : 00-8448-00-120-00-013-0-23-00

Operator Name : DIRECTOR, SUDA

Reference Number : 20190800002134

Net Amount : 381888

Reference Date : 19/08/2019

Status : Reference Generated

Sl. No.	Scheme Id	Scheme Description	Payee Treasury Code	Payee Treasury Name	Payee Operator Code	Payee Operator Name	Payee Scheme Id	Payee Scheme Description	Amount	Purpose
1	21097	COMMUNITY BASED	COD	Mathabhan ga	14	Chairman, Mathabhanga	22133	CBPHCS	381888	CBPHCS

Signature of the Assistant/Accountant

Printed By : DIPANKAR CHOWDHURY

Signature of the Administrator

Printed On : 19/08/2019 4:32 PM

Signature of Joint Signatory

Director

Calcutta Urban Development Agency

Calcutta PAO-III  
Reference Details

For

Xier -To Operator List For Personal Ledger Account/Local Fund Account/Provident Fund Account/Other Deposit Account

Operator Code : 19

Head of Account : 00-8448-00-120-00-013-0-23-00

Operator Name : DIRECTOR, SUDA

Reference Number : 2019080002136

Net Amount :

572771

Reference Date : 19/08/2019

Status : Reference Generated

Sl. No.	Scheme Id	Scheme Description	Payee Treasury Code	Payee Treasury Name	Payee Operator Code	Payee Operator Name	Payee Scheme Id	Payee Scheme Description	Amount	Purpose
1	21097	COMMUNITY BASED	MIA	Midnapore	25	CHAIRMAN MIDNAPORE	22304	CBPHCS	572771	CBPHCS

Signature of the Assistant/Accountant



Printed By : DIPANKAR CHOWDHURY

Signature of the Administrator

Printed On : 19/08/2019 4:34 PM

Signature of Joint Signatory



Page 1 of 1

Director  
Human Resource Development Agency

Calcutta PAO-III  
Reference Details

For  
Xfer -To Operator List For Personal Ledger Account/Local Fund Account/Provident Fund Account/Other Deposit Account

Operator Code : 19  
Operator Name : DIRECTOR, SUDA

Head of Account : 00-8448-00-120-00-013-0-23-00

Reference Number : 2019080002138

Net Amount :

801206

Reference Date : 19/08/2019

Status : Reference Generated

Sl. No.	Scheme Id	Scheme Description	Payee Treasury Code	Payee Treasury Name	Payee Operator Code	Payee Operator Name	Payee Scheme Id	Payee Scheme Description	Amount	Purpose
1	21097	COMMUNITY BASED	BRC	Rampurhat	10	CHAIRMAN, RAMPURHAT	22086	CBPHCS	377539	CBPHCS
2	21097	COMMUNITY BASED	BRC	Rampurhat	11	CHAIRMAN, NALHATI	22086	CBPHCS	423667	CBPHCS

Signature of the Assistant/Accountant

Signature of the Administrator

Signature of Joint Signatory

Printed By : DIPANKAR CHOWDHURY

Printed On : 19/08/2019 4:38 PM

Director

Director Development Agency



Calcutta PAO-III  
Reference Details

For

Xier -To Operator List For Personal Ledger Account/Local Fund Account/Provident Fund Account/Other Deposit Account

Operator Code : 19  
Operator Name : DIRECTOR, SUDA

Head of Account : 00-8448-00-120-00-013-0-23-00

Reference Number : 20190800002140

Net Amount :

413140

Reference Date : 19/08/2019

Status : Reference Generated

Sl. No.	Scheme Id	Scheme Description	Payee Treasury Code	Payee Treasury Name	Payee Operator Code	Payee Operator Name	Payee Scheme Id	Payee Scheme Description	Amount	Purpose
1	21097	COMMUNITY BASED	MDB	Malda-II	3	CHAIRMAN, OLD MALDA	22176	CBPHCS	413140	CBPHCS

Signature of the Assistant/Accountant



Signature of the Administrator

Printed By : DIPANKAR CHOWDHURY

Printed On : 19/08/2019 4:40 PM

Signature of Joint Signatory

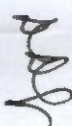

## Calcutta PAO-III

e-Advice For Personal Ledger Account/Local Fund Account/Provident Fund Account/Other Deposit Account

(For Transfer from one Operator to another Operator)

Operator Code : 19

Operator Designation : DIRECTOR, SUDA

Head of Account : 00-8448-00-120-00-013-0-23-00

Local Advice Id : 119

Memo No. : SUDA-67/2006(PT.-III)/16/9710

Local Advice Date : 20/08/2019

Memo Date : 20/08/2019

For use of the Operator												For use of Treasury/PAO	
Reference No.	Details of Payee Operator		Details of Recipient Operator							Amount(Rs.)	Purpose	Approved	Objected
	Scheme Id of Operator	Scheme Description of Operator	Payee Treasury code	Payee Treasury Name	Operator Code of Payee	Designation of Payee Operator	Scheme Id of Payee Operator	Scheme Description of Payee Operator	Head of Account of the Payee Operator				
2019080002143	21097	COMMUNITY BASED PRIMARY HEATH CARE	PUB	Raghunathpur	7	Chairman, Raghunathpur	22112	CBPHCS	00-8448-00-102-00-001-0-07-00	379161	CBPHCS		
2019080002145	21097	COMMUNITY BASED PRIMARY HEATH CARE	HGD	Chandemagore	7	Chairman, Tara keswar	22061	CBPHCS	00-8448-00-102-00-001-0-07-00	473908	CBPHCS		
2019080002146	21097	COMMUNITY BASED PRIMARY HEATH CARE	COF	Tufanganj	4	CHAIRMAN TUFANGANJ	22250	CBPHCS	00-8448-00-102-00-001-0-07-00	436786	CBPHCS		

Pay Rs. 1289835 Rupees(in words) Twelve Lakh Eighty Nine Thousand Eight Hundred Thirty Five only as transfer.



Assistant/Accountant

Signature of PL/LF/PF/OD Operator

Signature of Joint Signatory

Printed By: DEBARATI DATTA GUPTA

It is certified that the payment advice has been generated out of fund received during 2019-20

Page 1 of 1

Financial year 2019-20 vide Allotment

No. 358 (Sanction) / HF / P / PL / PH / HFW-B / 1 / 2018

Dated 11-08-2019



DIRECTOR

Sanitary Urban Development Agency

Calcutta PAO-III  
Reference Details

For

Xfer -To Operator List For Personal Ledger Account/Local Fund Account/Provident Fund Account/Other Deposit Account

Operator Code : 19

Head of Account : 00-8448-00-120-00-013-0-23-00

Operator Name : DIRECTOR, SUDA

Reference Number : 2019080002143

Net Amount : 379161

Reference Date : 19/08/2019

Status : Reference Generated

Sl. No.	Scheme Id	Scheme Description	Payee Treasury Code	Payee Treasury Name	Payee Operator Code	Payee Operator Name	Payee Scheme Id	Payee Scheme Description	Amount	Purpose
1	21097	COMMUNITY BASED	PUB	Raghunathpur	7	Chairman , Raghunathpur	22112	CBPHCS	379161	CBPHCS

Signature of the Assistant/Accountant

Signature of the Administrator

Signature of Joint Signatory

Printed By : DIPANKAR CHOWDHURY

Printed On : 19/08/2019 4:44 PM

Page 1 of 1

Calcutta PAO-III  
Reference Details

For

Xfer -To Operator List For Personal Ledger Account/Local Fund Account/Provident Fund Account/Other Deposit Account

Operator Code : 19

Head of Account : 00-8448-00-120-00-013-0-23-00

Operator Name : DIRECTOR, SUDA

Reference Number : 2019080002145

Net Amount :

473908

Reference Date : 19/08/2019

Status : Reference Generated

Sl. No.	Scheme Id	Scheme Description	Payee Treasury Code	Payee Treasury Name	Payee Operator Code	Payee Operator Name	Payee Scheme Id	Payee Scheme Description	Amount	Purpose
1	21097	COMMUNITY BASED	HGD	Chandernagore	7	Chairman, Tarakeswar	22081	CBPHCS	473908	CBPHCS

Signature of the Assistant/Accountant



Signature of the Administrator



Signature of Joint Signatory

Printed By : DIPANKAR CHOWDHURY

Printed On : 19/08/2019 4:46 PM

Director

Calcutta PAO-III  
Reference Details

For

Xier -To Operator List For Personal Ledger Account/Local Fund Account/Provident Fund Account/Other Deposit Account

Operator Code : 19

Head of Account : 00-8448-00-120-00-013-0-23-00

Operator Name : DIRECTOR, SUDA

Reference Number : 20190800002146

Net Amount :

436766

Reference Date : 19/08/2019

Status : Reference Generated

Sl. No.	Scheme Id	Scheme Description	Payee Treasury Code	Payee Treasury Name	Payee Operator Code	Payee Operator Name	Payee Scheme Id	Payee Scheme Description	Amount	Purpose
1	21097	COMMUNITY BASED	COF	Tufanganj	4	CHAIRMAN TUFANGANJ	22280	CBPHCS	436766	CBPHCS

Signature of the Assistant/Accountant

Printed By : DIPANKAR CHOWDHURY

Signature of the Administrator

Printed On : 19/08/2019 4:48 PM

Signature of Joint Signatory

Page 1 of 1

**Salary for CBPHCS ULBs for the month of July, Aug, Sept. 2019 and Ex Gratia for employees receiving salary more than Rs. 4000 pm**

Sl. No.	ULB	Actual entitlement of salary as per HR	List of employees entitled for ex gratia (Salary less than 30000 pm) who were in service on 31.3.2019 and rendered at least 6 months continuous service during the year 2018-19	No. of employees receiving salary more than Rs. 4000	Amount required for ex gratia @ Rs. 4000	Total amount to be released salary + ex gratia
1	Arambag	4,35,246.00	27	5	20,000.00	4,55,246.00
2	Ashokenagar Kalyangarh	5,49,807.00	50	5	20,000.00	5,69,807.00
3	Baduria	4,41,621.00	25	5	20,000.00	4,61,621.00
4	Bangaon	6,31,038.00	46	5	20,000.00	6,51,038.00
5	Bankura	5,05,404.00	46	6	24,000.00	5,29,404.00
6	Basirhat	5,54,496.00	49	6	24,000.00	5,78,496.00
7	Beldanga	3,64,563.00	21	4	16,000.00	3,80,563.00
8	Berhampur	5,95,752.00	56	5	20,000.00	6,15,752.00
9	Birnagar	3,64,554.00	21	4	16,000.00	3,80,554.00
10	Bishnupur	4,12,176.00	29	8	32,000.00	4,44,176.00
11	Bolpur	3,27,048.00	27	5	20,000.00	3,47,048.00
12	Chakdah	4,44,906.00	29	5	20,000.00	4,64,906.00
13	Chandrakona	3,15,573.00	19	4	16,000.00	3,31,573.00

**Salary for CBPHCS ULBs for the month of July, Aug, Sept. 2019 and Ex Gratia for employees receiving salary more than Rs. 4000 pm**

Sl. No.	ULB	Actual entitlement of salary as per HR	List of employees entitled for ex gratia (Salary less than 30000 pm) who were in service on 31.3.2019 and rendered at least 6 months continuous service during the year 2018-19	No. of employees receiving salary more than Rs. 4000	Amount required for ex gratia @ Rs. 4000	Total amount to be released salary + ex gratia
14	Contai	18,904.00	30	0	-	18,904.00
15	Cooch Behar	3,21,684.00	28	2	8,000.00	3,29,684.00
16	Coopers Camp	3,69,252.00	20	5	20,000.00	3,89,252.00
17	Dainhat	3,01,362.00	22	5	20,000.00	3,21,362.00
18	Dalkhola	2,56,923.00	21	4	16,000.00	2,72,923.00
19	Dhulian	2,75,076.00	26	4	16,000.00	2,91,076.00
20	Dhupguri	2,83,812.00	24	4	16,000.00	2,99,812.00
21	Diamond Harbour	3,09,126.00	25	5	20,000.00	3,29,126.00
22	Dinhata	3,91,452.00	24	4	16,000.00	4,07,452.00
23	Dubrajpur	3,91,452.00	24	4	16,000.00	4,07,452.00
24	Egra	4,06,572.00	24	5	20,000.00	4,26,572.00
25	Gangarampur	4,35,516.00	27	5	20,000.00	4,55,516.00
26	Ghatal	4,26,141.00	25	5	20,000.00	4,46,141.00
27	Gobardanga	4,18,182.00	25	4	16,000.00	4,34,182.00

**Salary for CBPHCS ULBs for the month of July, Aug, Sept. 2019 and Ex Gratia for employees receiving salary more than Rs. 4000 pm**

Sl. No.	ULB	Actual entitlement of salary as per HR	List of employees entitled for ex gratia (Salary less than 30000 pm) who were in service on 31.3.2019 and rendered at least 6 months continuous service during the year 2018-19	No. of employees receiving salary more than Rs. 4000	Amount required for ex gratia @ Rs. 4000	Total amount to be released salary + ex gratia
28	Gushkara	2,85,687.00	24	4	16,000.00	3,01,687.00
29	Habra	5,39,493.00	50	4	16,000.00	5,55,493.00
30	Haldia	5,87,940.00	48	2	8,000.00	5,95,940.00
31	Haldibari	3,51,918.00	18	4	16,000.00	3,67,918.00
32	Islampur	4,00,827.00	25	4	16,000.00	4,16,827.00
33	Jangipur	3,25,059.00	29	3	12,000.00	3,37,059.00
34	Jaynagar Mazilpur	3,88,002.00	20	5	20,000.00	4,08,002.00
35	Jhalda	3,68,802.00	20	5	20,000.00	3,88,802.00
36	Jhargram	1,00,854.00	26	4	16,000.00	1,16,854.00
37	Jiaganj Azimganj	4,53,330.00	27	6	24,000.00	4,77,330.00
38	Kaliaganj	4,00,803.00	25	4	16,000.00	4,16,803.00
39	Kalimpong	2,46,945.00	25	0	-	2,46,945.00
40	Kalna	3,73,098.00	30	6	24,000.00	3,97,098.00
41	Kandi	2,08,809.00	19	2	8,000.00	2,16,809.00



**Salary for CBPHCS ULBs for the month of July, Aug, Sept. 2019 and Ex Gratia for employees receiving salary more than Rs. 4000 pm**

Sl. No.	ULB	Actual entitlement of salary as per HR	List of employees entitled for ex gratia (Salary less than 30000 pm) who were in service on 31.3.2019 and rendered at least 6 months continuous service during the year 2018-19	No. of employees receiving salary more than Rs. 4000	Amount required for ex gratia @ Rs. 4000	Total amount to be released salary + ex gratia
42	Katwa	3,94,140.00	34	5	20,000.00	4,14,140.00
43	Kharar	3,55,968.00	17	5	20,000.00	3,75,968.00
44	Khirpai	2,93,595.00	15	3	12,000.00	3,05,595.00
45	Krishnagar	4,69,851.00	49	2	8,000.00	4,77,851.00
46	Kurseong	2,55,684.00	26	2	8,000.00	2,63,684.00
47	Mal	3,68,013.00	23	3	12,000.00	3,80,013.00
48	Mathabhanga	3,22,374.00	18	3	12,000.00	3,34,374.00
49	Medinipur	4,12,817.00	50	1	4,000.00	4,16,817.00
50	Mekhliganj	1,74,720.00	14	3	12,000.00	1,86,720.00
51	Memari	78,978.00	22	2	8,000.00	86,978.00
52	Mirik	2,90,319.00	13	4	16,000.00	3,06,319.00
53	Murshidabad	3,32,634.00	18	4	16,000.00	3,48,634.00

**Salary for CBPHCS ULBs for the month of July, Aug, Sept. 2019 and Ex Gratia for employees receiving salary more than Rs. 4000 pm**

Sl. No.	ULB	Actual entitlement of salary as per HR	List of employees entitled for ex gratia (Salary less than 30000 pm) who were in service on 31.3.2019 and rendered at least 6 months continuous service during the year 2018-19	No. of employees receiving salary more than Rs. 4000	Amount required for ex gratia @ Rs. 4000	Total amount to be released salary + ex gratia
54	Nabadwip	5,55,432.00	51	5	20,000.00	5,75,432.00
55	Nalhati	3,36,315.00	26	6	24,000.00	3,60,315.00
56	Old Malda	3,21,288.00	28	4	16,000.00	3,37,288.00
57	Panskura	4,18,182.00	25	4	16,000.00	4,34,182.00
58	Purulia	4,60,371.00	44	6	24,000.00	4,84,371.00
59	Raghunathpur	3,19,860.00	18	3	12,000.00	3,31,860.00
60	Ramjibanpur	3,59,877.00	19	5	20,000.00	3,79,877.00

**Salary for CBPHCS ULBs for the month of July, Aug, Sept. 2019 and Ex Gratia for employees receiving salary more than Rs. 4000 pm**

Sl. No.	ULB	Actual entitlement of salary as per HR	List of employees entitled for ex gratia (Salary less than 30000 pm) who were in service on 31.3.2019 and rendered at least 6 months continuous service during the year 2018-19	No. of employees receiving salary more than Rs. 4000	Amount required for ex gratia @ Rs. 4000	Total amount to be released salary + ex gratia
61	Rampurhat	2,95,062.00	25	4	16,000.00	3,11,062.00
62	Ranaghat	3,66,615.00	25	2	8,000.00	3,74,615.00
63	Sainthia	2,83,812.00	24	4	16,000.00	2,99,812.00
64	Santipur	5,82,318.00	56	3	12,000.00	5,94,318.00
65	Sonamukhi	2,93,487.00	23	5	20,000.00	3,13,487.00
66	Suri	2,82,045.00	25	2	8,000.00	2,90,045.00
67	Taherpur	2,70,987.00	21	5	20,000.00	2,90,987.00
68	Taki	4,19,871.00	24	5	20,000.00	4,39,871.00
69	Tamluk	4,63,341.00	31	4	16,000.00	4,79,341.00
70	Tarakeshwar	4,03,482.00	21	5	20,000.00	4,23,482.00
71	Tufanganj	3,69,252.00	20	5	20,000.00	3,89,252.00
<b>Total</b>		<b>2,61,29,895.00</b>	<b>1,981.00</b>	<b>290.00</b>	<b>11,60,000.00</b>	<b>2,72,89,895.00</b>

Rupees Two Crores Seventy Two Lakhs Eighty Nine Thousand Eight Hundred and Ninety Five Only

*[Handwritten Signature]*  
6/8/2019



Ex Gratia for employees of CBPHCS ULBs for the year 2019 receiving salary less than Rs. 4000 pm

Sl. No.	ULB	HHW @ Rs. 3125		FTS @ Rs. 3338		CERU @ Rs. 3250		GOA @ Rs. 3000		SWEEPERS @ Rs. 2750		AAM @ Rs. 3750		NIGHT GUARD @ Rs. 3000		Total
		No	(No. * 3125) Ex Gratia	No	(No. * 3338) Ex Gratia	No	(No. * 3250) Ex Gratia	No	(No. * 3000) Ex Gratia	No	(No. * 2750) Ex Gratia	No	(No. * 3750) Ex Gratia	No	(No. * 2750) Ex Gratia	
38	Kaliganj	17	53,125.00	4	13,352.00	0	-	0	-	0	-	0	-	0	-	66,477.00
39	Kalimpur	24	75,000.00	5	16,690.00	0	-	0	-	0	-	0	-	0	-	91,690.00
40	Kalna	17	53,125.00	2	6,676.00	1	3,250.00	1	3,000.00	1	2,750.00	2	7,500.00	0	-	76,301.00
41	Kandi	13	40,625.00	4	13,352.00	0	-	0	-	0	-	0	-	0	-	53,977.00
42	Karwa	24	75,000.00	5	16,690.00	0	-	0	-	0	-	0	-	0	-	91,690.00
43	Kharar	10	31,250.00	2	6,676.00	0	-	0	-	0	-	0	-	0	-	37,926.00
44	Khirpai	10	31,250.00	2	6,676.00	0	-	0	-	0	-	0	-	0	-	37,926.00
45	Krishnagar	34	1,06,250.00	7	23,366.00	0	-	1	3,000.00	1	2,750.00	3	11,250.00	1	2,750.00	1,49,366.00
46	Kurseong	20	62,500.00	4	13,352.00	0	-	0	-	0	-	0	-	0	-	75,852.00
47	Mai	16	50,000.00	4	13,352.00	0	-	0	-	0	-	0	-	0	-	63,352.00
48	Mathabhanga	12	37,500.00	3	10,014.00	0	-	0	-	0	-	0	-	0	-	47,514.00
49	Medinipur	34	1,06,250.00	8	26,704.00	1	3,250.00	1	3,000.00	1	2,750.00	3	11,250.00	1	2,750.00	1,55,984.00
50	Mehliganj	9	28,125.00	2	6,676.00	0	-	0	-	0	-	0	-	0	-	34,801.00
51	Memari	16	50,000.00	4	13,352.00	0	-	0	-	0	-	0	-	0	-	63,352.00
52	Mirik	7	21,875.00	2	6,676.00	0	-	0	-	0	-	0	-	0	-	28,551.00
53	Murshidabad	16	49,750.00	8	26,704.00	0	-	0	-	0	-	0	-	0	-	76,454.00
54	Nabadvip	38	1,18,750.00	8	26,704.00	0	-	0	-	0	-	0	-	0	-	1,45,454.00
55	Nalhati	16	50,000.00	4	13,352.00	0	-	0	-	0	-	0	-	0	-	63,352.00
56	Old Malda	20	62,500.00	4	13,352.00	0	-	0	-	0	-	0	-	0	-	75,852.00
57	Panskura	17	53,125.00	4	13,352.00	0	-	1	3,000.00	0	-	1	3,750.00	0	-	66,477.00
58	Purulia	29	90,625.00	6	20,028.00	0	-	0	-	0	-	0	-	0	-	1,20,653.00
59	Raghunathpur	13	40,625.00	2	6,676.00	0	-	0	-	0	-	0	-	0	-	47,301.00
60	Ramjibaspur	11	34,375.00	3	10,014.00	0	-	0	-	0	-	0	-	0	-	44,389.00
61	Ranpurhat	17	53,125.00	4	13,352.00	0	-	0	-	0	-	0	-	0	-	66,477.00
62	Ranghat	19	59,375.00	4	13,352.00	0	-	0	-	0	-	0	-	0	-	72,727.00
63	Sainthia	16	50,000.00	4	13,352.00	0	-	0	-	0	-	0	-	0	-	63,352.00
64	Santipur	44	1,37,500.00	9	30,442.00	0	-	0	-	0	-	0	-	0	-	1,67,942.00
65	Sonamukhi	15	46,875.00	3	10,014.00	0	-	0	-	0	-	0	-	0	-	56,889.00
66	Suri	18	56,250.00	3	10,014.00	0	-	1	3,000.00	1	2,750.00	0	-	0	-	72,014.00
67	Taketur	13	40,625.00	3	10,014.00	0	-	0	-	0	-	0	-	0	-	50,639.00
68	Taki	15	46,875.00	4	13,352.00	0	-	0	-	0	-	0	-	0	-	60,227.00
69	Tamluk	22	68,750.00	5	16,690.00	0	-	0	-	0	-	0	-	0	-	85,440.00
70	Tarakeswar	14	43,750.00	2	6,676.00	0	-	0	-	0	-	0	-	0	-	50,426.00
71	Tufanganj	12	37,500.00	3	10,014.00	0	-	0	-	0	-	0	-	0	-	47,514.00
	Total	1366	42,58,750.00	295	9,84,710.00	6	19,500.00	8	24,000.00	9	24,750.00	15	56,250.00	5	13,750.00	53,91,730.00

Total Rupees Fifty Three Lakhs Ninety One Thousand Seven Hundred and Ten Only.

Dr. 18/1/2019

Project : CBPHCS

Statement of fund status of ULBs (FY 2019-20) Name of the ULB \_\_\_\_\_ for the \_\_\_\_\_ quarter

Sl. No.	Head of Accounts	Opening Balance as on 01.04.2019			Fund received FY 2019-20		Expenditure Incurred	Balance left with ULB		SOE submitted till date		UC submitted till date
		Bank	Cash	Total	Date	Amount		Bank	Cash	Amount	Till date	
1	Honorarium											
2	Rent											
3	Contingency											
4	Drugs											

*Dr. S. S. S. S.*

## রাজ্য নগর উন্নয়ন সংস্থা

## STATE URBAN DEVELOPMENT AGENCY

“ইলগাস ভবন”, এইচ-সি ব্লক, সেক্টর-৩, বিধাননগর, কলকাতা-৭০০ ১০৬, পশ্চিমবঙ্গ  
 “ILGUS BHAVAN”, H-C Block, Sector - III, Bidhannagar, Kolkata - 700 106, West Bengal

ক্রমিক নং .....SUDA-67/2006(Pt.-III)/16/ <sup>4910</sup> (51)

তারিখ ..... 29.07.2019

**MEMORANDUM**

Funds are hereby released electronically in favour of Urban Local Bodies towards Honorarium / Salaries for the month of June, 2019 (including Salary of H.O by taking Dearness Allowance @ 242%) of F.Y 2019-20 as per details shown in the following page for implementation of Community Based Primary Health Care Services (CBPHCS) and HHW Scheme.

Statement of Expenditure (SOE) and Utilization (UC) may please be sent immediately after the cumulative funds on this component released in your favour is utilized.

Yours faithfully,

Encl. : As stated.

*Y. Hone*  
29/07/19  
Finance Officer, SUDA

Sl. No.	Name of ULB	Honorarium & Salaries	Payee Treasury code	Operator code of Payee	Scheme ID of the payee operator	Scheme description of payee operator
1	Arambag	150332	HGC	14	22119	CBPHCS
2	Asansol (Jamuria)	182945	BUD	1	22260	CBPHCS
3	Baduria	147207	NPE	4	22155	CBPHCS
4	Bangaon	207221	NPF	2	22289	CBPHCS
5	Bankura	172656	BAA	26	22192	CBPHCS
6	Basirhat	184832	NPE	3	22155	CBPHCS
7	Berhampur	218207	MUA	18	22184	CBPHCS
8	Birnagar	126681	NAD	21	22099	CBPHCS
9	Bolpur	110079	BRB	2	22479	CBPHCS
10	Chakdah	165645	NAC	15	22068	CBPHCS
11	Chandrakona	120431	MIC	9	22339	CBPHCS
12	Coopers Camp	128244	NAD	23	22099	CBPHCS
13	Dainhat	93454	BUG	7	22003	CBPHCS
14	Dalkhola	79391	UDA	23	22049	CBPHCS
15	Dhulian	101067	MUC	10	22245	CBPHCS
16	Dhuppuri	94604	JAA	57	22134	CBPHCS
17	Diamond Harbour	103042	SPC	12	22267	CBPHCS
18	Dinhata	135644	COC	5	22239	CBPHCS
19	Dubrajpur	135644	BRA	24	22050	CBPHCS
20	Gangarampur	101479	DDC	5	22036	CBPHCS
21	Ghatal	144082	MIC	6	22339	CBPHCS
22	Gobardanga	136269	NPA	10	22093	CBPHCS
23	Habra	188269	NPA	9	22093	CBPHCS
24	Haldia	208482	MID	20	22013	CBPHCS
25	Haldibari	76266	COE	3	22224	CBPHCS
26	Islampur	147207	UDA	7	22049	CBPHCS
27	Jangipur	106103	MUC	9	22245	CBPHCS
28	Jaynagar Mazilpur	134494	SPD	7	22181	CBPHCS
29	Jhalda	128244	PUC	1	22031	CBPHCS
30	Jhargram	141894	MIE	9	22106	CBPHCS
31	Jiaganj Azimganj	156270	MUE	9	22312	CBPHCS
32	Kaliaganj	106295	UDB	14	22207	CBPHCS
33	Kalna	135999	BUF	7	22994	CBPHCS
34	Katwa	72225	BUG	6	22003	CBPHCS
35	Kurseong	148144	DAB	11	22527	CBPHCS
36	Mal	144082	JAD	4	22214	CBPHCS
37	Mathabhanga	112618	COD	14	22133	CBPHCS
38	Medinipur	176830	MIA	14	22304	CBPHCS
39	Memari	125331	BUA	19	22362	CBPHCS
40	Mekhliganj	66678	COE	2	22224	CBPHCS
41	Murshidabad	75002	MUE	7	22312	CBPHCS
42	Nabadwip	194207	NAA	3	22149	CBPHCS
43	Nalhati	112105	BRC	11	22086	CBPHCS
44	Old Malda	107104	MDB	3	22176	CBPHCS
45	Panskura	147207	MIG	26	22069	CBPHCS
46	Purulia	135279	PUA	20	22377	CBPHCS
47	Raghunathpur	111780	PUB	7	22112	CBPHCS
48	Rampurhat	98282	BRC	10	22086	CBPHCS
49	Sonamukhi	97829	BAA	28	22192	CBPHCS
50	Tamluk	159607	MIG	36	22039	CBPHCS
51	Tufanganj	128244	COF	4	22280	CBPHCS

Dt. .. 29.07.2019

Memo No. .. SUDA-67/2006(Pt.-III)/16/ (51)/1

CC

1. The Mayor / Chairman / Administrator, ..... MC / Municipality

Finance Officer, SUDA



# GANGARAMPUR MUNICIPALITY

Gangarampur, Dakshin Dinajpur

Memo No-1458 /Health/GM/19-20

Date- 15.07.2019

To,

The Director (Health)  
State Urban Dev. Agency  
ILGUS Bhawan, Salt Lake,  
Kolkata- 700106

Sub- Submission of SOE of HHW fund under Gangarampur Municipality of June, 2019, with a request for release of further allotment.

Sir,

*In reference to the subject mentioned above the undersigned is to submit here with the above report along with all other relevant documents for favor of your kind information and taking necessary action.*

*You are requested to kindly make an urgent arrangement for release of fund for the CBPHCS of this Municipality.*

  
Chairman

Gangarampur Municipality  
Gangarampur, D/Dinajpur

  
Gangarampur Municipality  
Gangarampur, D/Dinajpur

**Gangarampur Municipality**  
**Status of Fund received & SOE submitted by**  
**the Gangarampur Municipality for HHW fund**

Name of the Month - June,2019

Financial Year	Opening Balance	Fund received from SUDA	Total fund available June,19	SOE sent up to the month of May,19.	SOE during the month of June,19.	Total SOE	Balance
2019-20	-166728.50 (18-19)	202958.00	36229.50	175613.00	150574.00	326187.00	-114344.50

*[Signature]*  
15/06/19

Chairman  
 Gangarampur Municipality  
 Gangarampur, D/Dianjpur  
 Gangarampur Municipality,  
 Gangarampur, D/Dianjpur

Monthly Summary Sheet on SOE of Gangarampur Municipality  
For the Month of June, 2019.

Sl. No	Item of Expenditure	Expenditure (Amount in Rs.)
<b>Non Recurring</b>		
1	Medical Equipment	
2	Furniture	
3	Construction (Not applicable for the present)	
	a) Sub-Centre	
	b) OPD cum maternity Home	
	c) OPD	
4	IEC & Materials	
5	Renovation Works	
6	Basic Line Survey	
7	Family Schedule, Training manual, HMIS format & HHW Kitbag	
8	Strengthening of existing Maternity Homes & Dispensaries ( Not applicable for the present)	
<b>Recurring</b>		
9	Honorarium	69602.00
10	Salaries	75570.00
11	Rent	
12	Training	
13	Drug	0.00
14	I.E.C	
15	Operating cost (Sundries, Printing, Postage & Telephone, TA/DA etc.)	5402.00
	<b>TOTAL</b>	<b>150574.00</b>

This is Certify that the amount as shown in the statement has been preferred earlier.

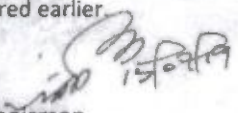
  
Chairman

Gangarampur Municipality  
Gangarampur, Dakshin Dinajpur

Gangarampur Municipality  
Gangarampus, D/Dinajpur

GANGARAMPUR MUNICIPALITY  
Gangarampur, D/Dinajpur  
Voucher Details Statement for the month of June, 2019.

Voucher No	Date	Item of expenditure	Nature of expenditure	Amount ( in Rs )
		Equipment		
		Furniture	Almirah , Table, Chair etc	
		Medicine		
		Training	Cost of training material	
			Trainers fee	
			Cost of Tiffin	
			Contingency /Operating Cost	
			Cost of cleaning charge of UHC No-1	500.00
			Cost of cleaning charge of UHC No-2	500.00
			Cost of cleaning charge of S.C No-3	500.00
			Cost of cleaning charge of S.C No-4	500.00
			Cost of Xerox bill	447.00
			Cost of Rickshaw fare	280.00
			Cost of Rickshaw fare	280.00
			Cost of Rickshaw fare	200.00
			Cost of Rickshaw fare	200.00
			Cost of tea & biscuits	320.00
			Cost of tea & biscuits	370.00
			Cost of tea & biscuits	390.00
			Cost of tea & biscuits	380.00
			Cost of tea & biscuits for Office use	35.00
			Total Rs -	5402.00
			Etc	
	01-10-18	Honorarium	Payments to HHW's & FTS. Honoharium for FTS & HHW (May,19 )	69602.00
			Total -	69602.00
		Salaries	Payment for M & S cell(Health Officer, Sanitary Inspector, Account Assistant, Computer Assistant, Health Assistant & Multipurpose Helper cum Store-keeper)	
			Salary for Health Officer (May,19)	35730.00
			P. Tax for Health Officer (May,19)	150.00
			Salary for Sanitary Inspector, Account Assistant, Computer Assistant, Health Assistant & Multipurpose Helper cum Storekeeper(May,19)	30690.00
			Total Rs	75570.00
			<b>TOTAL -</b>	<b>150574.00</b>

*(Signature)*  
Chairman

Gangarampur Municipality  
Gangarampur, D/Dinajpur

CHAIRMAN  
GANGARAMPUR MUNICIPALITY,  
GANGARAMPUR, D/DINAJPUR



GOVERNMENT OF WEST BENGAL  
Department of Health & Family Welfare  
PHP Branch

Swasthya Bhawan, GN-29, Sector-V, Salt Lake, Kolkata 700031

Tel:

Fax:

Memo No : 358(Sanction)/HF/P/P&B/PHP/HFW-13/1/2018

Date: 11/07/2019

Sanction Order for Grant-in-Aid

Demand No. : 24

Department Code : HF

Financial Year : 2019 - 2020

1. Sanctioning Authority: OFFICER ON SPECIAL DUTY & DEPUTY SECRETARY, PHP BRANCH
2. Name of the Grantee Institution: State Urban Development Agency
3. Address of the Grantee Institution: ILGUS Bhawan, HC Block, Sector-III, Bidhannagar, Kolkata-700091.
4. Category of Grantee Institution: Others
5. Amount Sanctioned: 60000000 (in words Rs. Six Crore Only. )
6. Name of the DDO: DIRECTOR, SUDA
7. Department Code: HF-OFFICER ON SPECIAL DUTY & DEPUTY SECRETARY, PHP BRANCH
8. Name of the Treasury/PAO: Pay & Accounts Officer-III, Calcutta PAO-III
9. Nature of Grant  
(a) Recurring or Non-recurring: Recurring  
(b) Capital or Revenue: Revenue
10. Condition of Grant  
Utilisation Certificate required: Yes
11. Category of Grant : Others
12. Purpose of Grant : To meet up the expenditure relating to Community Based primary Health Care Services (CBPHCS) and Honorary Health Worker(HHW)
13. An amount of Rs 60000000 is hereby allotted for this period in favour of the DIRECTOR, SUDA From the head of account 2210-06-800-00-002-31-02-V from the budget provision of the financial year,2019 - 2020 under Demand No.24 Department Code HF and payable to Grantee Institution or by A/c payee cheque/By-Transfer Credit / ECS.
14. Head of Account Code :2210-06-800-00-002-31-02-V
15. Name of the Scheme :Improvement of Urban Health Services
16. The amount will be drawn in T.R. from No.31 only.
17. The sanctioned amount will be payable to State Urban Development Agency by Transfer Credit to the Head of Account of the LF/PL/Deposit Account of the Grantee Institution or by A/C payee Cheque / ECS as applicable.
18. Remarks: AA & FS of an amount of Rs.6,00,00,000/- only is hereby allotted towards To meet up the expenditure relating to Community Based Primary Health Care Services (CBPHCS) and Honorary Health Worker (HHW) in this Financial Year 2019-20.  
The Sanctioned amount will be payable to the Grantee Institution by e-Pradan.
19. Total released amount is within the Budget Provision of the above mentioned head of account during 2019 - 2020
20. This order issues in exercise of the power delegated under Finance Department Memo. No. 1854-F.B. dated-26.03.2019with the concurrence of Finance Deptt. vide Gr. Financial Adviser Branch, H & FW Deptt. U.O. No. 86 Date 11/07/2019

OFFICER ON SPECIAL DUTY & DEPUTY SECRETARY  
OFFICER ON SPECIAL DUTY & DEPUTY SECRETARY, PHP BRANCH

**e-Advice For Personal Ledger Account/Local Fund Account/Provident Fund Account/Other Deposit Account  
(For Transfer from one Operator to another Operator )**

Operator Code : 19

Operator Designation : DIRECTOR, SUDA

Head of Account : 00-8448-00-120-00-013-0-23-00

Local Advice Id : 61

Memo No. : SUDA-87/2006(PT.-III)/16/4660

Local Advice Date : 15/07/2019

Memo Date : 15/07/2019

For use of the Operator

For use of  
Treasury/PAO

Reference No.	Details of Payee Operator		Details of Recipient Operator							Amount(Rs.)	Purpose	Approved	Objected
	Scheme Id of Operator	Scheme Description of Operator	Payee Treasury code	Payee Treasury Name	Operator Code of Payee	Designation of Payee Operator	Scheme Id of Payee Operator	Scheme Description of Payee Operator	Head of Account of the Payee Operator				
20190700001375	21097	COMMUNITY BASED PRIMARY HEATH CARE	HGC	Arambagh	14	CHAIRMANA RAMBAGH	22119	CBPHCS	00-8448-00-102-00-001-0-07-00	150332	CBPHCS		
20190700001378	21097	COMMUNITY BASED PRIMARY HEATH CARE	BUO	Asansol-II	1	Mayor, Asansol Municipal	22260	CBPHCS	00-8448-00-102-00-001-0-07-00	182945	CBPHCS		
20190700001377	21097	COMMUNITY BASED PRIMARY HEATH CARE	NPE	Basirhat	4	CHAIRMAN, BADURIA	22155	CBPHCS(SUD A)	00-8448-00-102-00-001-0-07-00	147207	CBPHCS		
20190700001377	21097	COMMUNITY BASED PRIMARY HEATH CARE	NPE	Basirhat	3	Chairman, Basirhat	22155	CBPHCS(SUD A)	00-8448-00-102-00-001-0-07-00	184832	CBPHCS		
20190700001380	21097	COMMUNITY BASED PRIMARY HEATH CARE	NPF	Bongaon	2	CHAIRMAN, BONGAON	22289	CBPHCS	00-8448-00-102-00-001-0-07-00	207221	CBPHCS		
20190700001381	21097	COMMUNITY BASED PRIMARY HEATH CARE	BAA	Bankura	28	CHAIRMAN, BANKURA	22182	COMMUNITY BASED	00-8448-00-102-00-001-0-07-00	172656	CBPHCS		
20190700001381	21097	COMMUNITY BASED PRIMARY HEATH CARE	BAA	Bankura	28	CHAIRMAN, SONAMUKHI	22182	COMMUNITY BASED	00-8448-00-102-00-001-0-07-00	97829	CBPHCS		

Pay Rs. 1143022 Rupees(in words) Eleven Lakh Forty Three Thousand Twenty Two only as transfer.



Assistant/Accountant

Signature of PL/LF/PF/OD Operator



Director

Signature of Joint Signatory

Printed By: DEBARATI DATTA GUPTA

State Urban Development Agency

Page 1 of 1

Calcutta PAO-III  
Reference Details

For

Xfer -To Operator List For Personal Ledger Account/Local Fund Account/Provident Fund Account/Other Deposit Account

Operator Code : 19

Head of Account : 00-8448-00-120-00-013-0-23-00

Operator Name : DIRECTOR, SUDA

Reference Number : 20190700001375

Net Amount : 150332

Reference Date : 15/07/2019

Status : Reference Generated

Sl. No.	Scheme Id	Scheme Description	Payee Treasury Code	Payee Treasury Name	Payee Operator Code	Payee Operator Name	Payee Scheme Id	Payee Scheme Description	Amount	Purpose
1	21097	COMMUNITY BASED	HGC	Arambagh	14	CHAIRMAN, ARAMB AGH	22119	CBPHCS	150332	CBPHCS

Signature of the Assistant/Accountant

Printed By : DIPANKAR CHOWDHURY

Signature of the Administrator

Printed On : 15/07/2019 12:42 PM

State Urban Development Agency

Director

Signature of Joint Signatory

Page 1 of 1

Calcutta PAO-III  
Reference Details

For

Xfer -To Operator List For Personal Ledger Account/Local Fund Account/Provident Fund Account/Other Deposit Account

Operator Code : 19

Head of Account : 00-8448-00-120-00-013-0-23-00

Operator Name : DIRECTOR, SUDA

Reference Number : 20190700001376

Net Amount : 182945

Reference Date : 15/07/2019

Status : Reference Generated

Sl. No.	Scheme Id	Scheme Description	Payee Treasury Code	Payee Treasury Name	Payee Operator Code	Payee Operator Name	Payee Scheme Id	Payee Scheme Description	Amount	Purpose
1	21097	COMMUNITY BASED	BUD	Asansol-II	1	Mayor,Asansol Municipal	22260	CBPHCS	182945	CBPHCS

Signature of the Assistant/Accountant

Signature of the Administrator

Director

Signature of Joint Signatory

Printed By : DIPANKAR CHOWDHURY

Printed On : 15/07/2019 12:43 PM

State Urban Development Agency

Page 1 of 1



Calcutta PAO-III  
Reference Details

For

Xfer -To Operator List For Personal Ledger Account/Local Fund Account/Provident Fund Account/Other Deposit Account

Operator Code : 19

Operator Name : DIRECTOR, SUDA

Head of Account : 00-8448-00-120-00-013-0-23-00

Reference Number : 20190700001377

Net Amount :

332039

Reference Date : 15/07/2019

Status : Reference Generated

Sl. No.	Scheme Id	Scheme Description	Payee Treasury Code	Payee Treasury Name	Payee Operator Code	Payee Operator Name	Payee Scheme Id	Payee Scheme Description	Amount	Purpose
1	21097	COMMUNITY BASED	NPE	Basirhat	3	Chairman, Basirhat Municipality	22155	CBPHCS(SUDA)	184832	CBPHCS
2	21097	COMMUNITY BASED	NPE	Basirhat	4	CHAIRMAN, BADURIA	22155	CBPHCS(SUDA)	147207	CBPHCS

Signature of the Assistant/Accountant



Printed By : DIPANKAR CHOWDHURY

Signature of the Administrator



Director

Printed On : 15/07/2019 12:45 PM

State Urban Development Agency

Signature of Joint Signatory

Calcutta PAO-III  
Reference Details

For

Xfer -To Operator List For Personal Ledger Account/Local Fund Account/Provident Fund Account/Other Deposit Account

Operator Code : 19

Head of Account : 00-8448-00-120-00-013-0-23-00

Operator Name : DIRECTOR, SUDA

Reference Number : 20190700001380

Net Amount : 207221

Reference Date : 15/07/2019

Status : Reference Generated

Sl. No.	Scheme Id	Scheme Description	Payee Treasury Code	Payee Treasury Name	Payee Operator Code	Payee Operator Name	Payee Scheme Id	Payee Scheme Description	Amount	Purpose
1	21097	COMMUNITY BASED	NPF	Bongaon	2	CHAIRMAN, BONGAON	22289	CBPHCS	207221	CBPHCS

Signature of the Assistant/Accountant



Printed By : DIPANKAR CHOWDHURY

Signature of the Administrator

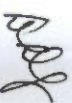

Printed On : 15/07/2019 12:47 PM

Signature of Joint Signatory

Page 1 of 1

Director  
State Urban Development Agency

Calcutta PAO-III  
Reference Details

For

Xier -To Operator List For Personal Ledger Account/Local Fund Account/Provident Fund Account/Other Deposit Account

Operator Code : 19

Head of Account : 00-8448-00-120-00-013-0-23-00

Operator Name : DIRECTOR, SUDA

Reference Number : 2019070000138-1

Net Amount : 270485

Reference Date : 15/07/2019

Status : Reference Generated

Sl. No.	Scheme Id	Scheme Description	Payee Treasury Code	Payee Treasury Name	Payee Operator Code	Payee Operator Name	Payee Scheme Id	Payee Scheme Description	Amount	Purpose
1	21097	COMMUNITY BASED	BAA	Bankura	28	CHAIRMAN, SONAMUKHI	22192	COMMUNITY BASED PRIMARY HEALTH CARE SERVICES	97829	CBPHCS
2	21097	COMMUNITY BASED	BAA	Bankura	26	CHAIRMAN, BANKURA	22192	COMMUNITY BASED PRIMARY HEALTH CARE SERVICES	172656	CBPHCS

Signature of the Assistant/Accountant

Printed By : DIPANKAR CHOWDHURY

Signature of the Administrator

Printed On : 15/07/2019 12:49 PM

Signature of Joint Signatory

Director  
State Urban Development Agency

## Calcutta PAO-III

e-Advice For Personal Ledger Account/Local Fund Account/Provident Fund Account/Other Deposit Account

(For Transfer from one Operator to another Operator)

Operator Code : 19

Operator Designation : DIRECTOR, SUDA

Head of Account : 00-8448-00-120-00-013-0-23-00

Local Advice Id : 62

Memo No. : SUDA-67/2006(PT.-III)/16/4661

Local Advice Date : 15/07/2019

Memo Date : 15/07/2019

For use of the Operator

For use of  
Treasury/PAO

Reference No.	Details of Payee Operator		Details of Recipient Operator							Amount(Rs.)	Purpose	Approved	Objected
	Scheme Id of Operator	Scheme Description of Operator	Payee Treasury code	Payee Treasury Name	Operator Code of Payee	Designation of Payee Operator	Scheme Id of Payee Operator	Scheme Description of Payee Operator	Head of Account of the Payee Operator				
20190700001382	21097	COMMUNITY BASED PRIMARY HEATH CARE	MUA	Berhampore-1	18	CHAIRMAN BERHAMPOR	22184	CBPHCS	00-8448-00-102-00-001-0-07-00	218207	CBPHCS		
20190700001383	21097	COMMUNITY BASED PRIMARY HEATH CARE	NAD	Ranaghat	21	Chairman, Birnagar	22069	CBPHCS	00-8448-00-102-00-001-0-07-00	128681	CBPHCS		
20190700001383	21097	COMMUNITY BASED PRIMARY HEATH CARE	NAD	Ranaghat	23	Chairman, Coopers Camp	22099	CBPHCS	00-8448-00-102-00-001-0-07-00	128244	CBPHCS		
20190700001384	21097	COMMUNITY BASED PRIMARY HEATH CARE	BRB	Bolpur	2	CHAIRMAN, BOLPUR	22479	CBPHCS(SUO A)	00-8448-00-102-00-001-0-07-00	110079	CBPHCS		
20190700001386	21097	COMMUNITY BASED PRIMARY HEATH CARE	NAC	Kalyani	15	CHAIRMAN, CHAKDAHIA	22088	CBPHCS	00-8448-00-102-00-001-0-07-00	165645	CBPHCS		
20190700001387	21097	COMMUNITY BASED PRIMARY HEATH CARE	MIC	Ghatal	9	Chairman, Chandrakona	22339	CBPHCS	00-8448-00-102-00-001-0-07-00	120431	CBPHCS		
20190700001387	21097	COMMUNITY BASED PRIMARY HEATH CARE	MIC	Ghatal	6	Chairman, Ghatal	22339	CBPHCS	00-8448-00-102-00-001-0-07-00	144082	CBPHCS		

Pay Rs. 1013369 Rupees(in words) Ten Lakh Thirteen Thousand Three Hundred Sixty Nine only as transfer.

  
Asst/Asnt/Accountant

Signature of PL/LF/PF/OD Operator

Signature of Joint Signatory

Printed By: DEBARATI DATTA GUPTA

  
**Director**  
State Urban Development Agency

Page 1 of 1

Calcutta PAO-III  
Reference Details

For

Xfer - To Operator List For Personal Ledger Account/Local Fund Account/Provident Fund Account/Other Deposit Account

Operator Code : 19

Operator Name : DIRECTOR, SUDA

Head of Account : 00-8448-00-120-00-013-0-23-00

Reference Number : 20190700001382

Reference Date : 15/07/2019

Net Amount :

218207

Status : Reference Generated

Sl. No.	Scheme Id	Scheme Description	Payee Treasury Code	Payee Treasury Name	Payee Operator Code	Payee Operator Name	Payee Scheme Id	Payee Scheme Description	Amount	Purpose
1	21097	COMMUNITY BASED	MUA	Berhampor e-I	18	CHAIRMAN BERHAMPORE	22184	CBPHCS	218207	CBPHCS

Signature of the Assistant/Accountant

Printed By : DIPANKAR CHOWDHURY

Signature of the Administrator

Printed On : 15/07/2019 12:51 PM

Signature of Joint Signatory

Director  
State Urban Development Agency

Calcutta PAO-III  
Reference Details

For

Xfer -To Operator List For Personal Ledger Account/Local Fund Account/Provident Fund Account/Other Deposit Account

Head of Account : 00-8448-00-120-00-013-0-23-00

Operator Code : 19

Operator Name : DIRECTOR, SUDA

Net Amount : 254925

Reference Number : 20190700001383

Reference Date : 15/07/2019

Status : Reference Generated

Sl. No.	Scheme Id	Scheme Description	Payee Treasury Code	Payee Treasury Name	Payee Operator Code	Payee Operator Name	Payee Scheme Id	Payee Scheme Description	Amount	Purpose
1	21097	COMMUNITY BASED	NAD	Ranaghat	23	Chairman, Coopers Camp Notified Area	22099	CBPHCS	128244	CBPHCS
2	21097	COMMUNITY BASED	NAD	Ranaghat	21	Chairman, Birnagar Municipality	22099	CBPHCS	126681	CBPHCS



Signature of the Assistant/Accountant

Printed By : DIPANKAR CHOWDHURY

Signature of the Administrator

Printed On : 15/07/2019 12:53 PM

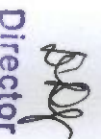

Director

State Urban Development Agency

Signature of Joint Signatory

Calcutta PAO-III  
Reference Details

For

Xfer - To Operator List For Personal Ledger Account/Local Fund Account/Provident Fund Account/Other Deposit Account

Operator Code : 19 Head of Account : 00-8448-00-120-00-013-0-23-00

Operator Name : DIRECTOR, SUDA

Reference Number : 20190700001384 Net Amount : 110079

Reference Date : 15/07/2019

Status : Reference Generated

Sl. No.	Scheme Id	Scheme Description	Payee Treasury Code	Payee Treasury Name	Payee Operator Code	Payee Operator Name	Payee Scheme Id	Payee Scheme Description	Amount	Purpose
1	21097	COMMUNITY BASED	BRB	Bolpur	2	CHAIRMAN, BOLPUR	22479	CBPHCS(SUDA)	110079	CBPHCS

Signature of the Assistant/Accountant



Printed By : DIPANKAR CHOWDHURY

Signature of the Administrator



Printed On : 15/07/2019 12:55 PM

Signature of Joint Signatory

Director

State Urban Development Agency

Calcutta PAO-III  
Reference Details

For  
Xfer - To Operator List For Personal Ledger Account/Local Fund Account/Provident Fund Account/Other Deposit Account

Operator Code : 19  
Operator Name : DIRECTOR, SUDA

Head of Account : 00-8448-00-120-00-013-0-23-00

Reference Number : 20190700001386

Net Amount : 165645

Reference Date : 15/07/2019

Status : Reference Generated

Sl. No.	Scheme Id	Scheme Description	Payee Treasury Code	Payee Treasury Name	Payee Operator Code	Payee Operator Name	Payee Scheme Id	Payee Scheme Description	Amount	Purpose
1	21097	COMMUNITY BASED	NAC	Kalyani	15	CHAIRMAN, CHAKDAHHA	22068	CBPHCS	165645	CBPHCS

Signature of the Assistant/Accountant

Printed By : DIPANKAR CHOWDHURY

Signature of the Administrator

Printed On : 15/07/2019 12:56 PM

Signature of Joint Signatory

  
Director  
State Urban Development Agency



Calcutta PAO-III  
Reference Details

For

Xfer -To Operator List For Personal Ledger Account/Local Fund Account/Provident Fund Account/Other Deposit Account

Operator Code : 19  
Operator Name : DIRECTOR, SUDA

Head of Account : 00-8448-00-120-00-013-0-23-00

Reference Number : 20190700001387

Net Amount : 264513

Reference Date : 15/07/2019

Status : Reference Generated

Sl. No.	Scheme Id	Scheme Description	Payee Treasury Code	Payee Treasury Name	Payee Operator Code	Payee Operator Name	Payee Scheme Id	Payee Scheme Description	Amount	Purpose
1	21097	COMMUNITY BASED	MIC	Ghatal	6	Chairman, Ghatal Municipality	22339	CBPHCS	144082	CBPHCS
2	21097	COMMUNITY BASED	MIC	Ghatal	9	Chairman, Chandrakona	22339	CBPHCS	120431	CBPHCS

Signature of the Assistant/Accountant



Signature of the Administrator



Signature of Joint Signatory

Printed By : DIPANKAR CHOWDHURY

Printed On : 15/07/2019 12:58 PM

Director  
State Urban Development Agency

Operator Code : 19

Operator Designation : DIRECTOR, SUDA

Head of Account : 00-8448-00-120-00-013-0-23-00

Local Advice Id : 63

Memo No. : SUDA-67/2006(PT.-II)/16/4662

Local Advice Date : 15/07/2019

Memo Date : 15/07/2019

For use of the Operator												For use of Treasury/PAO	
Reference No.	Details of Payee Operator		Details of Recipient Operator							Amount(Rs.)	Purpose	Approved	Objected
	Scheme Id of Operator	Scheme Description of Operator	Payee Treasury code	Payee Treasury Name	Operator Code of Payee	Designation of Payee Operator	Scheme Id of Payee Operator	Scheme Description of Payee Operator	Head of Account of the Payee Operator				
20190700001388	21097	COMMUNITY BASED PRIMARY HEATH CARE	BUG	Katwa	7	CHAIRMAN DAINHAT	22003	CBPHCS	00-8448-00-102-00-001-0-07-00	83454	CBPHCS		
20190700001388	21097	COMMUNITY BASED PRIMARY HEATH CARE	BUG	Katwa	8	CHAIRMAN KATWA	22003	CBPHCS	00-8448-00-102-00-001-0-07-00	72228	CBPHCS		
20190700001388	21097	COMMUNITY BASED PRIMARY HEATH CARE	UDA	Isiampur	23	Chairman, Dalkhola	22049	COMMUNITY BASED	00-8448-00-102-00-001-0-07-00	78391	CBPHCS		
20190700001388	21097	COMMUNITY BASED PRIMARY HEATH CARE	UDA	Isiampur	7	Chairman, Isiampur	22049	COMMUNITY BASED	00-8448-00-102-00-001-0-07-00	147207	CBPHCS		
20190700001390	21097	COMMUNITY BASED PRIMARY HEATH CARE	MUC	Jangipur	10	DHULIYAN MUNICIPALIT	22246	CBPHCS	00-8448-00-102-00-001-0-07-00	101087	CBPHCS		
20190700001390	21097	COMMUNITY BASED PRIMARY HEATH CARE	MUC	Jangipur	9	JANGIPUR MUNICIPALIT	22246	CBPHCS	00-8448-00-102-00-001-0-07-00	106103	CBPHCS		
20190700001394	21097	COMMUNITY BASED PRIMARY HEATH CARE	JAA	Jaipaguri-I	57	Chairman, Dhugguri	22134	CBPHCS	00-8448-00-102-00-001-0-07-00	94804	CBPHCS		
20190700001395	21097	COMMUNITY BASED PRIMARY HEATH CARE	SPC	Diamond Harbour	12	DIAMOND HARBOUR	22287	CBPHCS	00-8448-00-102-00-001-0-07-00	103042	CBPHCS		

Pay Rs. 797093 Rupees(in words) Seven Lakh Ninety Seven Thousand Ninety Three only as transfer.

Assistant/Accountant

Signature of PL/LF/PF/OD Operator

Signature of Joint Signatory

Printed By: DEBARATI DATTA GUPTA

  
**Director**  
 State Urban Development Agency

Page 1 of 1

Calcutta PAO-III  
Reference Details

For

Xier -To Operator List For Personal Ledger Account/Local Fund Account/Provident Fund Account/Other Deposit Account

Operator Code : 19

Operator Name : DIRECTOR, SUDA

Head of Account : 00-8448-00-120-00-013-0-23-00

Reference Number : 20190700001388

Net Amount :

Reference Date : 15/07/2019

165679

Status : Reference Generated

Sl. No.	Scheme Id	Scheme Description	Payee Treasury Code	Payee Treasury Name	Payee Operator Code	Payee Operator Name	Payee Scheme Id	Payee Scheme Description	Amount	Purpose
1	21097	COMMUNITY BASED	BUG	Katwa	6	CHAIRMAN KATWA MUNICIPALITY	22003	CBPHCS	72225	CBPHCS
2	21097	COMMUNITY BASED	BUG	Katwa	7	CHAIRMAN DAINHAT	22003	CBPHCS	93454	CBPHCS

Signature of the Assistant/Accountant



Printed By : DIPANKAR CHOWDHURY

Signature of the Administrator

Printed On : 15/07/2019 1:00 PM

Signature of Joint Signatory



Director

State Urban Development Agency

Calcutta PAO-III  
Reference Details

For

Xfer -To Operator List For Personal Ledger Account/Local Fund Account/Provident Fund Account/Other Deposit Account

Operator Code : 19

Operator Name : DIRECTOR, SUDA

Head of Account : 00-8448-00-120-00-013-0-23-00

Reference Number : 20190700001389

Net Amount :

Reference Date : 15/07/2019

226598

Status : Reference Generated

Sl. No.	Scheme Id	Scheme Description	Payee Treasury Code	Payee Treasury Name	Payee Operator Code	Payee Operator Name	Payee Scheme Id	Payee Scheme Description	Amount	Purpose
1	21097	COMMUNITY BASED	UDA	Islampur	7	Chairman, Islampur Municipality(LF)	22049	COMMUNITY BASED PRIMARY HEALTH CARE SERVICE	147207	CBPHCS
2	21097	COMMUNITY BASED	UDA	Islampur	23	Chairman, Dakhola Municipality(LF)	22049	COMMUNITY BASED PRIMARY HEALTH CARE SERVICE	79391	CBPHCS

Signature of the Assistant/Accountant

Printed By : DIPANKAR CHOWDHURY

Signature of the Administrator

Printed On : 15/07/2019 1:02 PM

Director

State Urban Development Agency

Signature of Joint Signatory

Page 1 of 1

Calcutta PAO-III  
Reference Details

For

Xfer -To Operator List For Personal Ledger Account/Local Fund Account/Provident Fund Account/Other Deposit Account

Operator Code : 19

Head of Account : 00-8448-00-120-00-013-0-23-00

Operator Name : DIRECTOR, SUDA

Reference Number : 20190700001390

Net Amount : 207170

Reference Date : 15/07/2019

Status : Reference Generated

Sl. No.	Scheme Id	Scheme Description	Payee Treasury Code	Payee Treasury Name	Payee Operator Code	Payee Operator Name	Payee Scheme Id	Payee Scheme Description	Amount	Purpose
1	21097	COMMUNITY BASED	MUC	Jangipur	9	JANGIPUR MUNICIPALITY	22245	CBPHCS	106103	CBPHCS
2	21097	COMMUNITY BASED	MUC	Jangipur	10	DHULIYAN MUNICIPALITY	22245	CBPHCS	101067	CBPHCS

Signature of the Assistant/Accountant



Signature of the Administrator



Director

Signature of Joint Signatory

Printed By : DIPANKAR CHOWDHURY

Printed On : 15/07/2019 1:06 PM

State Urban Development Agency

Page 1 of 1

Calcutta PAO-III  
Reference Details

For

Xfer -To Operator List For Personal Ledger Account/Local Fund Account/Provident Fund Account/Other Deposit Account

Operator Code : 19

Head of Account : 00-8448-00-120-00-013-0-23-00

Operator Name : DIRECTOR, SUDA

Reference Number : 20190700001394

Net Amount :

94604

Reference Date : 15/07/2019

Status : Reference Generated

Sl. No.	Scheme Id	Scheme Description	Payee Treasury Code	Payee Treasury Name	Payee Operator Code	Payee Operator Name	Payee Scheme Id	Payee Scheme Description	Amount	Purpose
1	21097	COMMUNITY BASED	JAA	Jalpaiguri-I	57	Chairman, Dhupguri Municipality.	22134	CBPHCS	94604	CBPHCS

Signature of the Assistant/Accountant



Printed By : DIPANKAR CHOWDHURY

Signature of the Administrator

Printed On : 15/07/2019 2:08 PM

Signature of Joint Signatory

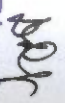
  
Director

State Urban Development Agency

Calcutta PAO-III  
Reference Details

For

Xier -To Operator List For Personal Ledger Account/Local Fund Account/Provident Fund Account/Other Deposit Account

Operator Code : 19

Operator Name : DIRECTOR, SUDA

Head of Account : 00-8448-00-120-00-013-0-23-00

Reference Number : 20190700001395

Reference Date : 15/07/2019

Net Amount :

103042

Status : Reference Generated

Sl. No.	Scheme Id	Scheme Description	Payee Treasury Code	Payee Treasury Name	Payee Operator Code	Payee Operator Name	Payee Scheme Id	Payee Scheme Description	Amount	Purpose
1	21097	COMMUNITY BASED	SPC	Diamond Harbour	12	DIAMOND HARBOUR	22267	CBPHCS	103042	CBPHCS

Signature of the Assistant/Accountant



Printed By : DIPANKAR CHOWDHURY

Signature of the Administrator

Printed On : 15/07/2019 2:09 PM



Director

Signature of Joint Signatory

State Urban Development Agency

Operator Code : 19

Operator Designation : DIRECTOR, SUDA

Head of Account : 00-8448-00-120-00-013-0-23-00

Local Advice Id : 64

Memo No. : SUDA-67/2006(PT.-III)/16/4663

Local Advice Date : 15/07/2019

Memo Date : 15/07/2019

For use of the Operator												For use of Treasury/PAO	
Details of Payee Operator			Details of Recipient Operator										
Reference No.	Scheme Id of Operator	Scheme Description of Operator	Payee Treasury code	Payee Treasury Name	Operator Code of Payee	Designation of Payee Operator	Scheme Id of Payee Operator	Scheme Description of Payee Operator	Head of Account of the Payee Operator	Amount(Rs.)	Purpose	Approved	Objected
20190700001396	21097	COMMUNITY BASED PRIMARY HEATH CARE	CDC	Dinhata	5	Chairman Dinhata	22238	CBPHCS	00-8448-00-102-00-001-0-07-00	135644	CBPHCS		
20190700001397	21097	COMMUNITY BASED PRIMARY HEATH CARE	BRA	Birbhum-I	24	CHAIRMAN DUBRAJPUR	22050	CBPHCS	00-8448-00-102-00-001-0-07-00	135644	CBPHCS		
20190700001398	21097	COMMUNITY BASED PRIMARY HEATH CARE	DDC	Gangarampur	5	CHAIRMAN, GANGARAMP	22036	CBPHCH	00-8448-00-102-00-001-0-07-00	101479	CBPHCS		
20190700001399	21097	COMMUNITY BASED PRIMARY HEATH CARE	NPA	Barasat-I	10	CHAIRMAN, GOBARDANG	22093	CBPHCS	00-8448-00-102-00-001-0-07-00	196269	CBPHCS		
20190700001399	21097	COMMUNITY BASED PRIMARY HEATH CARE	NPA	Barasat-I	9	CHAIRMAN, HABRA	22093	CBPHCS	00-8448-00-102-00-001-0-07-00	186269	CBPHCS		
20190700001400	21097	COMMUNITY BASED PRIMARY HEATH CARE	MID	Halda	20	CHAIR PERSON	22013	CBPHCS	00-8448-00-102-00-001-0-07-00	209482	CBPHCS		

Pay Rs. 905787 Rupees(in words) Nine Lakh Five Thousand Seven Hundred Eighty Seven only as transfer.



Assistant/Accountant

Signature of PULF/PF/OD Operator

Signature of Joint Signatory

Printed By: DEBARATI DATTA GUPTA

  
**Director**  
 State Urban Development Agency

Page 1 of 1



Calcutta PAO-III  
Reference Details

For

Xfer -To Operator List For Personal Ledger Account/Local Fund Account/Provident Fund Account/Other Deposit Account

Operator Code : 19  
Operator Name : DIRECTOR, SUDA

Head of Account : 00-8448-00-120-00-013-0-23-00

Reference Number : 20190700001396

Net Amount :

135644

Reference Date : 15/07/2019

Status : Reference Generated

Sl. No.	Scheme Id	Scheme Description	Payee Treasury Code	Payee Treasury Name	Payee Operator Code	Payee Operator Name	Payee Scheme Id	Payee Scheme Description	Amount	Purpose
1	21097	COMMUNITY BASED	COC	Dinhata	5	Chairman Dinhata Municipality.	22239	CBPHCS	135644	CBPHCS

Signature of the Assistant/Accountant

Printed By : DIPANKAR CHOWDHURY

Signature of the Administrator

Printed On : 15/07/2019 2:10 PM

Signature of Joint Signatory

Director  
State Urban Development Agency

Calcutta PAO-III  
Reference Details

Xfer -To Operator List For Personal Ledger Account/Local Fund Account/Provident Fund Account/Other Deposit Account  
For

Operator Code : 19

Operator Name : DIRECTOR, SUDA

Head of Account : 00-8448-00-120-00-013-0-23-00

Reference Number : 20190700001397

Reference Date : 15/07/2019

Net Amount :

135644

Status : Reference Generated

Sl. No.	Scheme Id	Scheme Description	Payee Treasury Code	Payee Treasury Name	Payee Operator Code	Payee Operator Name	Payee Scheme Id	Payee Scheme Description	Amount	Purpose
1	21097	COMMUNITY BASED	BRA	Birbhumi-I	24	CHAIRMAN DUBRAJPUR	22050	CBPHCS	135644	CBPHCS

Signature of the Assistant/Accountant

Printed By : DIPANKAR CHOWDHURY

Signature of the Administrator

Printed On : 15/07/2019 2:12 PM

Signature of Joint Signatory

Director

State Urban Development Agency

Calcutta PAO-III  
Reference Details

For

Xfer -To Operator List For Personal Ledger Account/Local Fund Account/Provident Fund Account/Other Deposit Account

Operator Code : 19 Head of Account : 00-8448-00-120-00-013-0-23-00

Operator Name : DIRECTOR, SUDA

Reference Number : 20190700001398

Reference Date : 15/07/2019

Net Amount :

101479

Status : Reference Generated

Sl. No.	Scheme Id	Scheme Description	Payee Treasury Code	Payee Treasury Name	Payee Operator Code	Payee Operator Name	Payee Scheme Id	Payee Scheme Description	Amount	Purpose
1	21097	COMMUNITY BASED	DDC	Gangarampur	5	CHAIRMAN, GANGARAMPUR	22036	CBPHCH	101479	CBPHCS

Signature of the Assistant/Accountant



Printed By : DIPANKAR CHOWDHURY

Signature of the Administrator

Printed On : 15/07/2019 2:14 PM

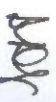

Director

State Urban Development Agency

Signature of Joint Signatory

For

Xfer -To Operator List For Personal Ledger Account/Local Fund Account/Provident Fund Account/Other Deposit Account

Operator Code : 19

Operator Name : DIRECTOR, SUDA

Head of Account : 00-8448-00-120-00-013-0-23-00

Reference Number : 20190700001399

Reference Date : 15/07/2019

Net Amount :

324538

Status : Reference Generated

Sl. No.	Scheme Id	Scheme Description	Payee Treasury Code	Payee Treasury Name	Payee Operator Code	Payee Operator Name	Payee Scheme Id	Payee Scheme Description	Amount	Purpose
1	21097	COMMUNITY BASED	NPA	Barasat-I	9	CHAIRMAN, HABRA	22093	CBPHCS	188269	CBPHCS
2	21097	COMMUNITY BASED	NPA	Barasat-I	10	CHAIRMAN, GOBARDANGA	22093	CBPHCS	136269	CBPHCS

Signature of the Assistant/Accountant

Printed By : DIPANKAR CHOWDHURY

Signature of the Administrator

Printed On : 15/07/2019 2:16 PM



Signature of Joint Signatory

Director  
State Urban Development Agency

Calcutta PAO-III  
Reference Details

For

Xier -To Operator List For Personal Ledger Account/Local Fund Account/Provident Fund Account/Other Deposit Account

Head of Account : 00-8448-00-120-00-013-0-23-00

Operator Code : 19

Operator Name : DIRECTOR, SUDA

Net Amount : 208482

Reference Number : 20190700001400

Reference Date : 15/07/2019

Reference Generated

Status :

Sl. No.	Scheme Id	Scheme Description	Payee Treasury Code	Payee Treasury Name	Payee Operator Code	Payee Operator Name	Payee Scheme Id	Payee Scheme Description	Amount	Purpose
1	21097	COMMUNITY BASED	MID	Haldia	20	CHAIR PERSON HALDIA	22013	CBPHCS	208482	CBPHCS

Signature of the Assistant/Accountant



Printed By : DIPANKAR CHOWDHURY

Signature of the Administrator

Printed On : 15/07/2019 2:17 PM



Director

State Urban Development Agency

Signature of Joint Signatory

## Calcutta PAO-III

e-Advice For Personal Ledger Account/Local Fund Account/Provident Fund Account/Other Deposit Account

(For Transfer from one Operator to another Operator )

Operator Code : 19

Operator Designation : DIRECTOR, SUDA

Head of Account : 00-8448-00-120-00-013-0-23-00

Local Advice Id : 65

Memo No. : SUDA-67/2008(PT.-III)/16/4664

Local Advice Date : 15/07/2019

Memo Date : 15/07/2019

For use of the Operator												For use of Treasury/PAO	
Details of Payee Operator			Details of Recipient Operator							Amount(Rs.)	Purpose	Approved	Objected
Reference No.	Scheme Id of Operator	Scheme Description of Operator	Payee Treasury code	Payee Treasury Name	Operator Code of Payee	Designation of Payee Operator	Scheme Id of Payee Operator	Scheme Description of Payee Operator	Head of Account of the Payee Operator				
20190700001401	21097	COMMUNITY BASED PRIMARY HEATH CARE	COE	Mekhliganj	3	CHAIRMAN, HALDIBARI	22224	CBPHCS	00-8448-00-102-00-001-0-07-00	76266	CBPHCS		
20190700001401	21097	COMMUNITY BASED PRIMARY HEATH CARE	COE	Mekhliganj	2	CHAIRMAN, MEKHLIGANJ	22224	CBPHCS	00-8448-00-102-00-001-0-07-00	66678	CBPHCS		
20190700001402	21097	COMMUNITY BASED PRIMARY HEATH CARE	SPD	Barulpur	7	CHAIRMAN, J OYNAGAR	22181	CBPHCS	00-8448-00-102-00-001-0-07-00	134494	CBPHCS		
20190700001403	21097	COMMUNITY BASED PRIMARY HEATH CARE	PUC	Jhalda	1	CHAIRMAN, JHALDA	22031	CBPHCS	00-8448-00-102-00-001-0-07-00	128244	CBPHCS		
20190700001404	21097	COMMUNITY BASED PRIMARY HEATH CARE	MIE	Jhargram	9	CHAIRMAN, JHARGRAM	22106	CBPHCS	00-8448-00-102-00-001-0-07-00	141894	CBPHCS		
20190700001405	21097	COMMUNITY BASED PRIMARY HEATH CARE	MUE	Lalbagh	9	CHAIRMAN, JAGANJ	22312	CBPHCS	00-8448-00-102-00-001-0-07-00	156270	CBPHCS		
20190700001405	21097	COMMUNITY BASED PRIMARY HEATH CARE	MUE	Lalbagh	7	CHAIRMAN, MURSHIDABA	22312	CBPHCS	00-8448-00-102-00-001-0-07-00	75002	CBPHCS		

Pay Rs. 778848 Rupees(in words) Seven Lakh Seventy Eight Thousand Eight Hundred Forty Eight only as transfer.

Assistant/Accountant

Signature of PL/LF/PF/OD Operator

Signature of Joint Signatory

Director

State Urban Development Agency

Printed By: DEBARATI DATTA GUPTA

Page 1 of 1

Calcutta PAO-III  
Reference Details

For

Xfer -To Operator List For Personal Ledger Account/Local Fund Account/Provident Fund Account/Other Deposit Account

Operator Code : 19

Head of Account : 00-8448-00-120-00-013-0-23-00

Operator Name : DIRECTOR, SUDA

Reference Number : 20190700001401

Net Amount : 142944

Reference Date : 15/07/2019

Status : Reference Generated

Sl. No.	Scheme Id	Scheme Description	Payee Treasury Code	Payee Treasury Name	Payee Operator Code	Payee Operator Name	Payee Scheme Id	Payee Scheme Description	Amount	Purpose
1	21097	COMMUNITY BASED	COE	Mekhliganj	2	CHAIRMAN, MEKHLIGANJ	22224	CBPHCS	66678	CBPHCS
2	21097	COMMUNITY BASED	COE	Mekhliganj	3	CHAIRMAN, HALDIBARI	22224	CBPHCS	76266	CBPHCS

Signature of the Assistant/Accountant

Signature of the Administrator

Signature of Joint Signatory

Printed By : DIPANKAR CHOWDHURY

Printed On : 15/07/2019 2:21 PM

Director  
State Urban Development Agency

Page 1 of 1

Calcutta PAO-III  
Reference Details

For

Xfer - To Operator List For Personal Ledger Account/Local Fund Account/Provident Fund Account/Other Deposit Account

Operator Code : 19

Operator Name : DIRECTOR, SUDA

Head of Account : 00-8448-00-120-00-013-0-23-00

Reference Number : 20190700001402

Net Amount :

134494

Reference Date : 15/07/2019

Status : Reference Generated

Sl. No.	Scheme Id	Scheme Description	Payee Treasury Code	Payee Treasury Name	Payee Operator Code	Payee Operator Name	Payee Scheme Id	Payee Scheme Description	Amount	Purpose
1	21097	COMMUNITY BASED	SPD	Baruipur	7	CHAIRMAN,JOYNA GAR	22181	CBPHCS	134494	CBPHCS

Signature of the Assistant/Accountant

Printed By : DIPANKAR CHOWDHURY

Signature of the Administrator

Printed On : 15/07/2019 2:24 PM

Signature of Joint Signatory

Director

State Urban Development Agency



Calcutta PAO-III  
Reference Details

For

Xfer -To Operator List For Personal Ledger Account/Local Fund Account/Provident Fund Account/Other Deposit Account

Operator Code : 19

Operator Name : DIRECTOR, SUDA

Head of Account : 00-8448-00-120-00-013-0-23-00

Reference Number : 20190700001403

Net Amount :

Reference Date : 15/07/2019

128244

Status : Reference Generated

Sl. No.	Scheme Id	Scheme Description	Payee Treasury Code	Payee Treasury Name	Payee Operator Code	Payee Operator Name	Payee Scheme Id	Payee Scheme Description	Amount	Purpose
1	21097	COMMUNITY BASED	PUC	Jhalda	1	CHAIRMAN, JHALDA	22031	CBPHCS	128244	CBPHCS

Signature of the Assistant/Accountant

Printed By : DIPANKAR CHOWDHURY

Signature of the Administrator

Printed On : 15/07/2019 2:25 PM

Signature of Joint Signatory

Director

State Urban Development Agency

Calcutta PAO-III  
Reference Details

For

Xfer - To Operator List For Personal Ledger Account/Local Fund Account/Provident Fund Account/Other Deposit Account

Operator Code : 19  
Operator Name : DIRECTOR, SUDA

Head of Account : 00-8448-00-120-00-013-0-23-00

Reference Number : 20190700001404

Net Amount :

141894

Reference Date : 15/07/2019

Status : Reference Generated

Sl. No.	Scheme Id	Scheme Description	Payee Treasury Code	Payee Treasury Name	Payee Operator Code	Payee Operator Name	Payee Scheme Id	Payee Scheme Description	Amount	Purpose
1	21097	COMMUNITY BASED	MIE	Jhargram	9	CHAIRMAN, JHARGRAM	22106	CBPHCS	141894	CBPHCS

Signature of the Assistant/Accountant



Signature of the Administrator



Signature of Joint Signatory

Printed By : DIPANKAR CHOWDHURY

Printed On : 15/07/2019 2:27 PM

Director  
State Urban Development Agency

Calcutta PAO-III  
Reference Details

For

Xfer - To Operator List For Personal Ledger Account/Local Fund Account/Provident Fund Account/Other Deposit Account

Operator Code : 19  
Operator Name : DIRECTOR, SUDA

Head of Account : 00-8448-00-120-00-013-0-23-00

Reference Number : 20190700001405

Net Amount :

231272

Reference Date : 15/07/2019

Status : Reference Generated

Sl. No.	Scheme Id	Scheme Description	Payee Treasury Code	Payee Treasury Name	Payee Operator Code	Payee Operator Name	Payee Scheme Id	Payee Scheme Description	Amount	Purpose
1	21097	COMMUNITY BASED	MUE	Lalbagh	7	CHAIRMAN, MURSHIDABAD	22312	CBPHCS	75002	CBPHCS
2	21097	COMMUNITY BASED	MUE	Lalbagh	9	CHAIRMAN, JIAGANJ-	22312	CBPHCS	156270	CBPHCS

Signature of the Assistant/Accountant



Signature of the Administrator



Signature of Joint Signatory

Printed By : DIPANKAR CHOWDHURY

Printed On : 15/07/2019 2:29 PM

Director  
State Urban Development Agency

## Calcutta PAO-III

e-Advice For Personal Ledger Account/Local Fund Account/Provident Fund Account/Other Deposit Account

(For Transfer from one Operator to another Operator)

Operator Code : 19

Operator Designation : DIRECTOR, SUDA

Head of Account : 00-8448-00-120-00-013-0-23-00

Local Advice Id : 66

Memo No. : SUDA-67/2006(PT.-III)/16/4665

Local Advice Date : 15/07/2019

Memo Date : 15/07/2019

For use of the Operator											For use of Treasury/PAO			
Details of Payee Operator			Details of Recipient Operator											
Reference No.	Scheme Id of Operator	Scheme Description of Operator	Payee Treasury code	Payee Treasury Name	Operator Code of Payee	Designation of Payee Operator	Scheme Id of Payee Operator	Scheme Description of Payee Operator	Head of Account of the Payee Operator	Amount(Rs.)	Purpose	Approved	Objected	
20190700001408	21097	COMMUNITY BASED PRIMARY HEATH CARE	UDS	Raigunj-I	14	Chairman, Kallagan	22207	CBPHCS	00-8448-00-102-00-001-0-07-00	106295	CBPHCS			
20190700001407	21097	COMMUNITY BASED PRIMARY HEATH CARE	BUF	Kalna	7	CHAIRMAN KALNA	21994	CBPHCS	00-8448-00-102-00-001-0-07-00	135999	CBPHCS			
20190700001408	21097	COMMUNITY BASED PRIMARY HEATH CARE	DAB	Kurseong	11	Chairman, Kurseong	22527	CBPHCS(HH W)	00-8448-00-102-00-001-0-07-00	148144	CBPHCS			
20190700001409	21097	COMMUNITY BASED PRIMARY HEATH CARE	JAD	Mal	4	CHAIRMAN MAL	22214	CBPHCS	00-8448-00-102-00-001-0-07-00	144082	CBPHCS			
20190700001410	21097	COMMUNITY BASED PRIMARY HEATH CARE	COD	Mathebhanga	14	Chairman, Mathebhanga	22133	CBPHCS	00-8448-00-102-00-001-0-07-00	112618	CBPHCS			

Pay Rs. 647138 Rupees(in words) Six Lakh Forty Seven Thousand One Hundred Thirty Eight only as transfer.



Assistant/Accountant

Signature of PL/LF/PF/OD Operator

Signature of Joint Signatory

Printed By: DEBARATI DATTA GUPTA



**Director**  
State Urban Development Agency

Page 1 of 1

Calcutta PAO-III  
Reference Details

For

Xfer -To Operator List For Personal Ledger Account/Local Fund Account/Provident Fund Account/Other Deposit Account

Operator Code : 19

Head of Account : 00-8448-00-120-00-013-0-23-00

Operator Name : DIRECTOR, SUDA

Reference Number : 20190700001406

Net Amount : 106295

Reference Date : 15/07/2019

Status : Reference Generated

Sl. No.	Scheme Id	Scheme Description	Payee Treasury Code	Payee Treasury Name	Payee Operator Code	Payee Operator Name	Payee Scheme Id	Payee Scheme Description	Amount	Purpose
1	21097	COMMUNITY BASED	UDB	Raigunj-I	14	Chairman, Kaliaganj Municipality, -LF A/C	22207	CBPHCS	106295	CBPHCS

Signature of the Assistant/Accountant



Printed By : DIPANKAR CHOWDHURY

Signature of the Administrator

Printed On : 15/07/2019 2:31 PM

Signature of Joint Signatory



Director

State Urban Development Agency

Calcutta PAO-III  
Reference Details

For

Xier - To Operator List For Personal Ledger Account/Local Fund Account/Provident Fund Account/Other Deposit Account

Operator Code : 19  
Operator Name : DIRECTOR, SUDA

Head of Account : 00-8448-00-120-00-013-0-23-00

Reference Number : 20190700001407

Net Amount :

135999

Reference Date : 15/07/2019

Status : Reference Generated

Sl. No.	Scheme Id	Scheme Description	Payee Treasury Code	Payee Treasury Name	Payee Operator Code	Payee Operator Name	Payee Scheme Id	Payee Scheme Description	Amount	Purpose
1	21097	COMMUNITY BASED	BUF	Kalna	7	CHAIRMAN KALNA MUNICIPALITY	21994	CBPHCS	135999	CBPHCS

Signature of the Assistant/Accountant

Printed By : DIPANKAR CHOWDHURY

Signature of the Administrator

Printed On : 15/07/2019 2:33 PM

Signature of Joint Signatory

Director  
State Urban Development Agency

Calcutta PAO-III  
Reference Details

For  
Xfer - To Operator List For Personal Ledger Account/Local Fund Account/Provident Fund Account/Other Deposit Account

Operator Code : 19  
Operator Name : DIRECTOR, SUDA

Head of Account : 00-8448-00-120-00-013-0-23-00

Reference Number : 20190700001408

Net Amount :

148144

Reference Date : 15/07/2019

Status : Reference Generated

Sl. No.	Scheme Id	Scheme Description	Payee Treasury Code	Payee Treasury Name	Payee Operator Code	Payee Operator Name	Payee Scheme Id	Payee Scheme Description	Amount	Purpose
1	21097	COMMUNITY BASED	DAB	Kurseong	11	Chairman, Kurseong Municipality	22527	CBPHCS(HHW)	148144	CBPHCS

Signature of the Assistant/Accountant



Printed By : DIPANKAR CHOWDHURY

Signature of the Administrator

Printed On : 15/07/2019 2:34 PM

Signature of Joint Signatory



Director

State Urban Development Agency

Calcutta PAO-III  
Reference Details

For

Xfer -To Operator List For Personal Ledger Account/Local Fund Account/Provident Fund Account/Other Deposit Account

Operator Code : 19

Operator Name : DIRECTOR, SUDA

Head of Account : 00-8448-00-120-00-013-0-23-00

Reference Number : 20190700001409

Net Amount :

Reference Date : 15/07/2019

144082

Status : Reference Generated

Sl. No.	Scheme Id	Scheme Description	Payee Treasury Code	Payee Treasury Name	Payee Operator Code	Payee Operator Name	Payee Scheme Id	Payee Scheme Description	Amount	Purpose
1	21097	COMMUNITY BASED	JAD	Mal	4	CHAIRMAN, MAL MUNICIPALITY	22214	CBPHCS	144082	CBPHCS

Signature of the Assistant/Accountant

Printed By : DIPANKAR CHOWDHURY

Signature of the Administrator

Printed On : 15/07/2019 2:35 PM

Signature of Joint Signatory

Director  
State Urban Development Agency



Calcutta PAO-III  
Reference Details

For  
Xier -To Operator List For Personal Ledger Account/Local Fund Account/Provident Fund Account/Other Deposit Account

Operator Code : 19  
Operator Name : DIRECTOR, SUDA  
Reference Number : 20190700001410  
Reference Date : 15/07/2019  
Status : Reference Generated

Head of Account : 00-8448-00-120-00-013-0-23-00  
Net Amount : 112618

Sl. No.	Scheme Id	Scheme Description	Payee Treasury Code	Payee Treasury Name	Payee Operator Code	Payee Operator Name	Payee Scheme Id	Payee Scheme Description	Amount	Purpose
1	21097	COMMUNITY BASED	COD	Mathabhanga	14	Chairman, Mathabhanga	22133	CBPHCS	112618	CBPHCS

Signature of the Assistant/Accountant

Printed By : DIPANKAR CHOWDHURY

Signature of the Administrator

Printed On : 15/07/2019 2:36 PM

Signature of Joint Signatory

Director  
State Urban Development Agency

e-Advice For Personal Ledger Account/Local Fund Account/Provident Fund Account/Other Deposit Account  
(For Transfer from one Operator to another Operator)

Operator Code : 19

Operator Designation : DIRECTOR, SUDA

Head of Account : 00-8448-00-120-00-013-0-23-00

Local Advice Id : 67

Memo No. : SUDA-67/2006(PT.-III)/16/4666

Local Advice Date : 15/07/2019

Memo Date : 15/07/2019

## For use of the Operator

For use of  
Treasury/PAC

Reference No.	Details of Payee Operator		Details of Recipient Operator							Amount(Rs.)	Purpose	Approved	Objected
	Scheme Id of Operator	Scheme Description of Operator	Payee Treasury code	Payee Treasury Name	Operator Code of Payee	Designation of Payee Operator	Scheme Id of Payee Operator	Scheme Description of Payee Operator	Head of Account of the Payee Operator				
20190700001411	21097	COMMUNITY BASED PRIMARY HEATH CARE	MIA	Midnapore	25	CHAIRMAN MIDNAPORE	22304	CBPHCS	00-8448-00-102-00-001-0-07-00	176630	CBPHCS		
20190700001412	21097	COMMUNITY BASED PRIMARY HEATH CARE	BUA	Burdwan-I	19	CHAIRMAN, MEMARI	22362	CBPHCS(2018-19)	00-8448-00-102-00-001-0-07-00	126331	CBPHCS		
20190700001413	21097	COMMUNITY BASED PRIMARY HEATH CARE	NAA	KrishnaNagar-I	3	Nabadwip Municipality	22149	CBPHCS  COMMUNITY	00-8448-00-102-00-001-0-07-00	194207	CBPHCS		
20190700001414	21097	COMMUNITY BASED PRIMARY HEATH CARE	BRC	Rampurhat	11	CHAIRMAN, NALHATI	22086	CBPHCS	00-8448-00-102-00-001-0-07-00	112105	CBPHCS		
20190700001414	21097	COMMUNITY BASED PRIMARY HEATH CARE	BRC	Rampurhat	10	CHAIRMAN, RAMPURHAT	22086	CBPHCS	00-8448-00-102-00-001-0-07-00	98262	CBPHCS		
20190700001415	21097	COMMUNITY BASED PRIMARY HEATH CARE	MDB	Malda-II	3	CHAIRMAN, OLD MALDA	22176	CBPHCS	00-8448-00-102-00-001-0-07-00	107104	CBPHCS		

Pay Rs. 813859 Rupees(in words) Eight Lakh Thirteen Thousand Eight Hundred Fifty Nine only as transfer.

  
Assistant/Accountant

Signature of PL/LF/PF/OD Operator

  
Signature of Joint Signatory

Printed By: DEBARATI DATTA GUPTA

**Director**  
**State Urban Development Agency**

Page 1 of 1

Calcutta PAO-III  
Reference Details

For

Xier -To Operator List For Personal Ledger Account/Local Fund Account/Provident Fund Account/Other Deposit Account

Operator Code : 19

Operator Name : DIRECTOR, SUDA

Head of Account : 00-8448-00-120-00-013-0-23-00

Reference Number : 20190700001411

Net Amount :

176830

Reference Date : 15/07/2019

Status : Reference Generated

Sl. No.	Scheme Id	Scheme Description	Payee Treasury Code	Payee Treasury Name	Payee Operator Code	Payee Operator Name	Payee Scheme Id	Payee Scheme Description	Amount	Purpose
1	21097	COMMUNITY BASED	MIA	Midnapore	25	CHAIRMAN MIDNAPORE	22304	CBPHCS	176830	CBPHCS

Signature of the Assistant/Accountant



Printed By : DIPANKAR CHOWDHURY

Signature of the Administrator

Printed On : 15/07/2019 2:44 PM

Signature of Joint Signatory



Director

State Urban Development Agency

Calcutta PAO-III  
Reference Details

For

Xfer -To Operator List For Personal Ledger Account/Local Fund Account/Provident Fund Account/Other Deposit Account

Operator Code : 19

Operator Name : DIRECTOR, SUDA

Head of Account : 00-8448-00-120-00-013-0-23-00

Reference Number : 20190700001412

Net Amount :

125331

Reference Date : 15/07/2019

Status : Reference Generated

Sl. No.	Scheme Id	Scheme Description	Payee Treasury Code	Payee Treasury Name	Payee Operator Code	Payee Operator Name	Payee Scheme Id	Payee Scheme Description	Amount	Purpose
1	21097	COMMUNITY BASED	BUA	Burdwan-I	19	CHAIRMAN, MEMARI	22362	CBPHCS(2018-19)	125331	CBPHCS

Signature of the Assistant/Accountant

Printed By : DIPANKAR CHOWDHURY

Signature of the Administrator

Printed On : 15/07/2019 2:46 PM

Signature of Joint Signatory

Page 1 of 1

Director  
State Urban Development Agency

Calcutta PAO-III  
Reference Details

For

Xfer - To Operator List For Personal Ledger Account/Local Fund Account/Provident Fund Account/Other Deposit Account

Operator Code : 19

Head of Account : 00-8448-00-120-00-013-0-23-00

Operator Name : DIRECTOR, SUDA

Reference Number : 20190700001413

Net Amount :

194207

Reference Date : 15/07/2019

Status : Reference Generated

Sl. No.	Scheme Id	Scheme Description	Payee Treasury Code	Payee Treasury Name	Payee Operator Code	Payee Operator Name	Payee Scheme Id	Payee Scheme Description	Amount	Purpose
1	21097	COMMUNITY BASED	NAA	KrishnaNagar-I	3	Nabadwip Municipality	22149	CBPHCS( COMMUNITY BASED PRIMARY HEALTH CARE	194207	CBPHCS

Signature of the Assistant/Accountant

Printed By : DIPANKAR CHOWDHURY

Signature of the Administrator

Printed On : 15/07/2019 2:47 PM

Signature of Joint Signatory

Director  
State Urban Development Agency

Calcutta PAO-III  
Reference Details

For

Xfer -To Operator List For Personal Ledger Account/Local Fund Account/Provident Fund Account/Other Deposit Account

Operator Code : 19

Operator Name : DIRECTOR, SUDA

Head of Account : 00-8448-00-120-00-013-0-23-00

Reference Number : 20190700001414

Reference Date : 15/07/2019

Net Amount :

210387

Status : Reference Generated

Sl. No.	Scheme Id	Scheme Description	Payee Treasury Code	Payee Treasury Name	Payee Operator Code	Payee Operator Name	Payee Scheme Id	Payee Scheme Description	Amount	Purpose
1	21097	COMMUNITY BASED	BRC	Rampurhat	10	CHAIRMAN, RAMPURHAT	22086	CBPHCS	98282	CBPHCS
2	21097	COMMUNITY BASED	BRC	Rampurhat	11	CHAIRMAN, NALHATI	22086	CBPHCS	112105	CBPHCS

Signature of the Assistant/Accountant

Printed By : DIPANKAR CHOWDHURY

Signature of the Administrator

Printed On : 15/07/2019 2:49 PM

Signature of Joint Signatory

  
Director

State Urban Development Agency

Calcutta PAO-III  
Reference Details

For

Xfer - To Operator List For Personal Ledger Account/Local Fund Account/Provident Fund Account/Other Deposit Account

Operator Code : 19

Operator Name : DIRECTOR, SUDA

Head of Account : 00-8448-00-120-00-013-0-23-00

Reference Number : 20190700001415

Reference Date : 15/07/2019

Net Amount :

107104

Status : Reference Generated

Sl. No.	Scheme Id	Scheme Description	Payee Treasury Code	Payee Treasury Name	Payee Operator Code	Payee Operator Name	Payee Scheme Id	Payee Scheme Description	Amount	Purpose
1	21097	COMMUNITY BASED	MDB	Malda-II	3	CHAIRMAN, OLD MALDA	22176	CBPHCS	107104	CBPHCS

Signature of the Assistant/Accountant

Printed By : DIPANKAR CHOWDHURY

Signature of the Administrator

Printed On : 15/07/2019 2:51 PM

Signature of Joint Signatory

Page 1 of 1

Director  
State Urban Development Agency

Operator Code : 19

Operator Designation : DIRECTOR, SUDA

Head of Account : 00-8448-00-120-00-013-0-23-00

Local Advice Id : 68

Memo No. : SUDA-67/2006(PT-III)/16/4667

Local Advice Date : 15/07/2019

Memo Date : 15/07/2019

For use of the Operator												For use of Treasury/PAO	
Details of Payee Operator			Details of Recipient Operator										
Reference No.	Scheme Id of Operator	Scheme Description of Operator	Payee Treasury code	Payee Treasury Name	Operator Code of Payee	Designation of Payee Operator	Scheme Id of Payee Operator	Scheme Description of Payee Operator	Head of Account of the Payee Operator	Amount(Rs.)	Purpose	Approved	Objected
20190700001416	21097	COMMUNITY BASED PRIMARY HEATH CARE	MIG	Tamiluk	26	Panskura Municipality	22069	CBPHCS	00-8448-00-102-00-001-0-07-00	147207	CBPHCS		
20190700001416	21097	COMMUNITY BASED PRIMARY HEATH CARE	MIG	Tamiluk	36	Chairman, Tamiluk	22069	CBPHCS	00-8448-00-102-00-001-0-07-00	159607	CBPHCS		
20190700001417	21097	COMMUNITY BASED PRIMARY HEATH CARE	PJA	Purulia	20	CHAIRMAN PURULIA	22377	CBPHCS	00-8448-00-102-00-001-0-07-00	135279	CBPHCS		
20190700001418	21097	COMMUNITY BASED PRIMARY HEATH CARE	PUB	Raghunathpur	7	Chairman, Raghunathpur	22112	CBPHCS	00-8448-00-102-00-001-0-07-00	111780	CBPHCS		
20190700001419	21097	COMMUNITY BASED PRIMARY HEATH CARE	COF	Tufanganj	4	CHAIRMAN TUFANGANJ	22280	CBPHCS	00-8448-00-102-00-001-0-07-00	128244	CBPHCS		

Pay Rs. 682117 Rupees(in words) Six Lakh Eighty Two Thousand One Hundred Seventeen only as transfer.

Assistant/Accountant

Signature of PULF/PF/OD Operator

Director

Signature of Joint Signatory

Printed By: DEBARATI DATTA GUPTA

State Urban Development Agency

Page 1 of 1



Calcutta PAO-III  
Reference Details

Xier -To Operator List For Personal Ledger Account/Local Fund Account/Provident Fund Account/Other Deposit Account  
For

Operator Code : 19

Operator Name : DIRECTOR, SUDA

Head of Account : 00-8448-00-120-00-013-0-23-00

Reference Number : 20190700001416

Net Amount :

306814

Reference Date : 15/07/2019

Status : Reference Generated

Sl. No.	Scheme Id	Scheme Description	Payee Treasury Code	Payee Treasury Name	Payee Operator Code	Payee Operator Name	Payee Scheme Id	Payee Scheme Description	Amount	Purpose
1	21097	COMMUNITY BASED	MIG	Tamiluk	36	Chairman, Tamiluk Municipality/	22069	CBPHCS	159607	CBPHCS
2	21097	COMMUNITY BASED	MIG	Tamiluk	26	Panskura Municipality (8448)	22069	CBPHCS	147207	CBPHCS

Signature of the Assistant/Accountant

Printed By : DIPANKAR CHOWDHURY

Signature of the Administrator

Printed On : 15/07/2019 2:52 PM

Signature of Joint Signatory

Director  
State Urban Development Agency

Calcutta PAO-III  
Reference Details

For

Xfer -To Operator List For Personal Ledger Account/Local Fund Account/Provident Fund Account/Other Deposit Account

Operator Code : 19 Head of Account : 00-8448-00-120-00-013-0-23-00

Operator Name : DIRECTOR, SUDA

Reference Number : 20190700001417

Reference Date : 15/07/2019

Net Amount :

135279

Status : Reference Generated

Sl. No.	Scheme Id	Scheme Description	Payee Treasury Code	Payee Treasury Name	Payee Operator Code	Payee Operator Name	Payee Scheme Id	Payee Scheme Description	Amount	Purpose
1	21097	COMMUNITY BASED	PUA	Purulia	20	CHAIRMAN PURULLA	22377	CBPHCS	135279	CBPHCS

Signature of the Assistant/Accountant

Printed By : DIPANKAR CHOWDHURY

Signature of the Administrator

Printed On : 15/07/2019 2:54 PM

Signature of Joint Signatory

Director  
State Urban Development Agency

Calcutta PAO-III  
Reference Details

For

Xfer - To Operator List For Personal Ledger Account/Local Fund Account/Provident Fund Account/Other Deposit Account

Operator Code : 19

Head of Account : 00-8448-00-120-00-013-0-23-00

Operator Name : DIRECTOR, SUDA

Reference Number : 20190700001418

Net Amount : 111780

Reference Date : 15/07/2019

Status : Reference Generated

Sl. No.	Scheme Id	Scheme Description	Payee Treasury Code	Payee Treasury Name	Payee Operator Code	Payee Operator Name	Payee Scheme Id	Payee Scheme Description	Amount	Purpose
1	21097	COMMUNITY BASED	PUB	Raghunathpur	7	Chairman, Raghunathpur	22112	CBPHCS	111780	CBPHCS

Signature of the Assistant/Accountant



Printed By : DIPANKAR CHOWDHURY

Signature of the Administrator

Printed On : 15/07/2019 2:55 PM

Signature of Joint Signatory



Director

State Urban Development Agency

Calcutta PAO-III  
Reference Details

For

Xier -To Operator List For Personal Ledger Account/Local Fund Account/Provident Fund Account/Other Deposit Account

Operator Code : 19

Head of Account : 00-8448-00-120-00-013-0-23-00

Operator Name : DIRECTOR, SUDA

Reference Number : 20190700001419

Net Amount : 128244

Reference Date : 15/07/2019

Status : Reference Generated

Sl. No.	Scheme Id	Scheme Description	Payee Treasury Code	Payee Treasury Name	Payee Operator Code	Payee Operator Name	Payee Scheme Id	Payee Scheme Description	Amount	Purpose
1	21097	COMMUNITY BASED	COF	Tufanganj	4	CHAIRMAN TUFANGANJ	22280	CBPHCS	128244	CBPHCS

Signature of the Assistant/Accountant



Printed By : DIPANKAR CHOWDHURY

Signature of the Administrator

Printed On : 15/07/2019 2:56 PM

Signature of Joint Signatory



Director

State Urban Development Agency

## CBPHCS - As on till date

Sl. No.	ULB	Balance in hand by ULB			SOE Submitted upto the Month of
		Drug	Non-Drug	Total	
1	Arambag	-410246	74457	-335789	June, 2019
2	Ashokenagar Kalyangarh	1637098	571152	2208250	December, 2018
3	Baduria	54429	86422	140851	May, 2019
4	Bangaon	569030	343094	912124	March, 2019
5	Basirhat	1655062	-1166262	488800	March, 2019
6	Beldanga	256678	1133285	1389963	October, 2018
7	Birnagar	-342123	705102	362979	April, 2019
8	Chakdah	126282	254427	380709	April, 2019
9	Chandrakona	20249	178828	199077	May, 2019
10	Contai	261169	1776038	2037207	August, 2018
11	Coopers Camp	8065	87475	95540	May, 2019
12	Dainhat	3031	-79290	-76259	May, 2019
13	Dalkhola	-104282	668963	564681	April, 2019
14	Dhulian	371863	646555	1018418	February, 2019
15	Dhupguri	193944	-83856	110088	May, 2019
16	Diamondharbour	117333	-32813	84520	May, 2019
17	Dinhata	-68509	167051	98542	May, 2019
18	Dubrajpur	223607	155723	379330	May, 2019
19	Egra	700620	251103	951723	October, 2018
20	Gangarampur	996149	-959919	36230	April, 2019
21	Ghatal	-150557	374395	223838	March, 2019
22	Gobardanga	177149	176020	353169	April, 2019
23	Gushkara	325054	765831	1090885	October, 2018
24	Habra	509922	-302944	206978	May, 2019
25	Haldia	-258810	549446	290636	February, 2019
26	Haldibari	636815	-469471	167344	March, 2019
27	Islampur	585927	-259615	326312	May, 2019
28	Jamuraia	649667	1092984	1742651	March, 2019
29	Jaynagar Mazilpur	92078	261962	354040	March, 2019
30	Jhalda	5579	315032	320611	April, 2019
31	Jhargram	-19628	374508	354880	May, 2019
32	Jiaganj Azimganj	-47516	336144	288628	March, 2019
33	Kaliaganj	787594	-201532	586062	April, 2019
34	Kalimpong	684571	11967	696538	October, 2018
35	Kandi	756279	-54673	701606	April, 2019
36	Katwa	388386	58168	446554	March, 2019
37	Kharar	53462	512313	565775	December, 2018
38	Khirpai	161210	352187	513397	March, 2019
39	Kulti	0	371408	371408	
40	Kurseong	319360	739516	1058876	May, 2019
41	Mal	625647	-251962	373685	April, 2019
42	Mathabhanga	652207	-115972	536235	May, 2019
43	Mekhliganj	322000	105318	427318	May, 2019
44	Memari	995726	340505	1336231	April, 2019
45	Mirik	403235	899576	1302811	July, 2018
46	Murshidabad	374724	-370311	4413	April, 2019
47	Nabadwip	2303290	-739485	1563805	April, 2019
48	Nalhati	232458	257420	489878	March, 2019
49	Old Malda	601728	182003	783731	April, 2019
50	Panskura	424697	-161658	263039	May, 2019
51	Raghunathpur	-70682	-96199	-166881	March, 2019
52	Ramjibanpur	221200	825837	1047037	November, 2018
53	Rampurhat	1027214	-509124	518090	May, 2019
54	Ranaghat	-764296	1682961	918665	December, 2018
55	Raniganj	734682	1327161	2061843	October, 2018
56	Sainthia	1043644	227770	1271414	December, 2018
57	Santipur	1428318	2713708	4142026	November, 2017
58	Sonamukhi	393727	-273608	120119	May, 2019
59	Taherpur	189425	818622	1008047	November, 2018
60	Taki	320714	779609	1100323	December, 2018
61	Tamluk	328588	476333	804921	March, 2019
62	Tarakeshwar	148948	532796	681744	December, 2018
63	Tufanganj	549514	-199367	350147	March, 2019
<b>Total =&gt;</b>		<b>24412699</b>	<b>18233114</b>	<b>42645813</b>	

SIPA-67/2017 (P.T.T.)  
 CBPHCS  
 Enclosed  
 papers.

**HHW Scheme - As on till date**

Sl. No.	ULB	Balance in hand by ULB			SOE Submitted upto the Month of
		Drug	Non-Drug	Total	
1	Berhampore	215367	663869	<b>879236</b>	March., 2019
2	Bankura	62439	-114987	<b>-52548</b>	June, 2019
3	Bishnupur	84652	898915	<b>983567</b>	November, 2018
4	Bolpur	298814	182735	<b>481549</b>	April, 2019
5	Jangipur	202592	133400	<b>335992</b>	March., 2019
6	Kalna	421471	-62222	<b>359249</b>	April, 2019
7	Cooch Behar	527319	1074871	<b>1602190</b>	July, 2018
8	Krishnagar	381307	1080249	<b>1461556</b>	November, 2018
9	Medinipur	199388	109323	<b>308711</b>	April, 2019
10	Purulia	612362	-367513	<b>244849</b>	May, 2019
11	Suri	367783	3565	<b>371348</b>	May, 2019
<b>Total=&gt;</b>		<b>3373494</b>	<b>3602205</b>	<b>6975699</b>	

**ULB-wise Sanctioned & Existing  
Manpower under CBPHCS and HHW**

Sl. No.	ULBs	Programme	Manpower at Field Level																
			HHW		FTS		PTMO		ANM		Clerk		GDA		Night		Sweeper		
			S	E	S	E	S	E	S	E	S	E	S	E	S	E	S	E	
1	Arambag	CBPHCS	18	18	4	4													
2	Ashokenagar	CBPHCS	37	37	8	8													
3	Baduria	CBPHCS	17	17	4	4													
4	Bangaon	CBPHCS	34	33	7	7													
5	Bankura	HHW Scheme	28	28	6	6	3	3	3	3	1	1	1	1	1	0	1	1	1
6	Basirhat	CBPHCS	38	35	8	8													
7	Beldanga	CBPHCS	14	14	3	2													
8	Berhampur	HHW Scheme	40	40	8	8	3	2	3	3	1	0	1	1	1	0	1	1	0
9	Biragar	CBPHCS	14	14	3	3													
10	Bishnupur	HHW Scheme	19	14	3	3	2	2	2	2	1	1	1	1	1	1	1	1	1
11	Bolpur	HHW Scheme	18	17	3	3	2	2	2	0	1	1	1	1	1	0	1	1	0
12	Chakdah	CBPHCS	20	20	4	4													
13	Chandrakona	CBPHCS	12	12	3	3													
14	Contai	CBPHCS	26	26	5	5													
15	Cooch Behar	HHW Scheme	20	19	4	4	2	0	2	1	1	1	1	1	1	1	1	1	1
16	Coopers Camp	CBPHCS	12	12	3	3													
17	Dainhat	CBPHCS	14	14	3	3													
18	Dalkhola	CBPHCS	14	12	3	3													
19	Dhulian	CBPHCS	19	17	4	4													
20	Dhupguri	CBPHCS	16	16	4	4													
21	Diamond Harbour	CBPHCS	16	16	4	4													
22	Dinhat	CBPHCS	16	16	4	4													
23	Dubrajpur	CBPHCS	16	16	4	4													
24	Egra	CBPHCS	14	14	3	3													
25	Gangarampur	CBPHCS	18	18	4	4													
26	Ghatal	CBPHCS	17	16	4	4													
27	Gobardanga	CBPHCS	17	16	4	4													
28	Gushkara	CBPHCS	16	16	4	4													
29	Habra	CBPHCS	40	39	8	8													
30	Haldia	CBPHCS	45	44	9	9													

Sl. No.	ULBs	Programme	Manpower at Field Level																
			HHW		FTS		PTMO		ANM		Clerk		GDA		Night		Sweeper		
			S	E	S	E	S	E	S	E	S	E	S	E	S	E	S	E	
31	Haldibari	CBPHCS	11	11	3	3													
32	Islampur	CBPHCS	17	17	4	4													
33	Asansol (Jamuria)	CBPHCS	29	29	6	6													
34	Jangpur	HHW Scheme	20	18	4	4	2	0	2	1	1	1	1	1	1	1	1	1	1
35	Jaynagar Mazilpur	CBPHCS	14	14	3	3													
36	Jhalda	CBPHCS	12	12	3	3													
37	Jhargram	CBPHCS	18	18	4	4													
38	Jiaganj Azimganj	CBPHCS	17	17	4	4													
39	Kalaganj	CBPHCS	17	17	4	4													
40	Kalimpong	CBPHCS	23	21	5	4													
41	Kalna	HHW Scheme	18	18	3	3	2	1	2	2	1	1	1	1	1	0	1	1	1
42	Kandi	CBPHCS	17	13	4	4													
43	Katwa	CBPHCS	24	23	5	5													
44	Kharar	CBPHCS	10	10	2	2													
45	Khirpai	CBPHCS	10	10	2	2													
46	Krishnagar	HHW Scheme	35	35	7	7	3	0	3	3	1	1	1	1	1	1	1	1	1
47	Asansol (Kulti)	CBPHCS	76		13														
48	Kurseong	CBPHCS	20	20	4	4													
49	Mal	CBPHCS	16	16	4	4													
50	Mathabhanga	CBPHCS	12	12	3	3													
51	Medinipur	HHW Scheme	38	36	8	8	3	0	3	3	1	1	1	1	1	1	1	1	1
52	Mekhiganj	CBPHCS	9	9	2	2													
53	Memari	CBPHCS	16	15	4	4													
54	Mirik	CBPHCS	9	8	2	2													
55	Murshidabad	CBPHCS	16	14	4	0													
56	Nabadwip	CBPHCS	38	38	8	8													
57	Nalhati	CBPHCS	16	16	4	4													
58	Old Malda	CBPHCS	20	20	4	4													
59	Panskura	CBPHCS	17	17	4	4													
60	Purulia	HHW Scheme	29	26	6	6	3	0	3	2	1	1	1	1	1	0	1	1	1



Sl. No.	ULBs	Programme	Manpower at Field Level																	
			HHW		FTS		PTMO		ANM		Clerk		GDA		Night		Sweeper			
			S	E	S	E	S	E	S	E	S	E	S	E	S	E	S	E		
61	Raghunathpur	CBPHCS	13	13	2	2														
62	Ranjibanpur	CBPHCS	11	11	3	3														
63	Rampurhat	CBPHCS	17	17	4	4														
64	Ranaghat	CBPHCS	19	18	4	4														
65	Asansol (Raniganj)	CBPHCS	36	35	7	6														
66	Sainthia	CBPHCS	16	16	4	4														
67	Santipur	CBPHCS	46	46	9	7														
68	Sonamukhi	CBPHCS	15	15	3	3														
69	Suri	HHW Scheme	18	17	3	3	2	0	2	0	1	1	1	1	1	0	1	1		
70	Taherpur	CBPHCS	13	10	3	3														
71	Taki	CBPHCS	16	16	4	4														
72	Tamluk	CBPHCS	22	22	5	5														
73	Tarakshwar	CBPHCS	15	15	3	2														
74	Tufanganj	CBPHCS	12	12	3	3														
<b>Total =&gt;</b>			<b>1538</b>	<b>1419</b>	<b>328</b>	<b>306</b>	<b>27</b>	<b>10</b>	<b>27</b>	<b>20</b>	<b>11</b>	<b>9</b>	<b>11</b>	<b>11</b>	<b>11</b>	<b>5</b>	<b>11</b>	<b>9</b>		

S = Sanctioned  
E = Existing

**ULB-wise Sanctioned & Existing  
Manpower under CBPHCS and HHW**

Sl. No.	ULBs	Programme	Manpower at ULB Level for Management & Supervisors																	
			HO 41040		AHO 11563		MO 9063		PHN 7188		SI 8438		Comp. Asst			Accs. Asst				
			S	E	S	E	S	E	S	E	S	E	S	E	S	E	S	E		
1	Arambag	CBPHCS	1	1			1	0			1	1	1	1			1	1		
2	Ashokenagar	CBPHCS	1	1			2	2			1	1	1	1			1	1		
3	Baduria	CBPHCS	1	1			1				1	1	1	1			1	1		
4	Bangaon	CBPHCS	1	1			2				1	1	1	1			1	1	1	
5	Bankura	HHW Scheme	1	0			0	0			1	1	0	0			1	1		
6	Basirhat	CBPHCS	1	0			2	1			1	1	1	0			1	1		
7	Beldanga	CBPHCS	1	1							1	1	1	1			1	1	1	
8	Berhampur	HHW Scheme	1	0			1	0			1	1	0	0			1	1		
9	Biragar	CBPHCS	1	1							1	1	1	1			1	1	1	
10	Bishnupur	HHW Scheme	1	0			0	0			1	1	0	0			1	1	1	
11	Bolpur	HHW Scheme	1	0			1	0			1	1	0	0			1	1	1	
12	Chakdah	CBPHCS	1	1			1	1			1	1	1	1			1	1	1	
13	Chandrakona	CBPHCS	1	1			1	1			1	1	0	1			1	1	1	
14	Contai	CBPHCS	1	1			1	1			0	0					1	0	0	
15	Cooch Behar	HHW Scheme	1	0			0	0			1	1	1	1			1	1	1	
16	Coopers Camp	CBPHCS	1	1							1	1	1	1			1	1	1	
17	Dainhat	CBPHCS	1	0							1	1	1	1			1	1	1	
18	Dalkhola	CBPHCS	1	0							1	1	1	1			1	1	1	
19	Dhulian	CBPHCS	1	0			1	0			1	0	1	1			1	1	1	
20	Dhupguri	CBPHCS	1	0							1	1	1	1			1	1	1	
21	Diamond Harbour	CBPHCS	1	0							1	1	1	1			1	1	1	
22	Dinhata	CBPHCS	1	1							1	1	0	1			1	1	1	
23	Dubrajpur	CBPHCS	1	1							1	1	1	1			1	1	1	
24	Egra	CBPHCS	1	1							1	1	1	1			1	1	1	
25	Gangarampur	CBPHCS	1	0			1				1	1	1	1			1	1	1	
26	Ghatal	CBPHCS	1	1			1	0			1	1	1	1			1	1	1	
27	Gobardanga	CBPHCS	1	1			1				1	1	1	1			1	1	1	
28	Gushkara	CBPHCS	1	0							1	1	1	0			1	1	1	
29	Habra	CBPHCS	1	0			2	0			1	1	1	1			1	1	1	
30	Haldia	CBPHCS	1	0			2	1			1	1	1	1			1	1	1	

Sl. No.	ULBs	Programme	Manpower at ULB Level for Management & Supervis																	
			HO		AHO		MO		PHN		SI		Comp. Asst		Accts. Asst					
			S	E	S	E	S	E	S	E	S	E	S	E	S	E				
31	Haldibari	CBPHCS	1	0																
32	Islampur	CBPHCS	1	1																
33	Asansol (Jamuria)	CBPHCS	1	1		2														
34	Jangipur	HHW Scheme	1	0		0		1		1		0				1				1
35	Jaynagar Mazilpur	CBPHCS	1	1																
36	Jhalda	CBPHCS	1	1																
37	Jhargram	CBPHCS	1	1																
38	Jiaganj Azimganj	CBPHCS	1	1																
39	Kaliaganj	CBPHCS	1	0																
40	Kalimpong	CBPHCS	1	0																
41	Kalna	HHW Scheme	1	0		1		1		1		0				1				1
42	Kandi	CBPHCS	1	0																
43	Katwa	CBPHCS	1	0																
44	Kharar	CBPHCS	1	0																
45	Khirpai	CBPHCS	1	0																
46	Krishnagar	HHW Scheme	1	0																
47	Asansol (Kulti)	CBPHCS	1	0		4														
48	Kurseong	CBPHCS	1	1																
49	Mal	CBPHCS	1	1																
50	Mathabhanga	CBPHCS	1	1																
51	Medinipur	HHW Scheme	1	0				1		1		0				1				1
52	Mekhliganj	CBPHCS	1	0																
53	Memari	CBPHCS	1	1																
54	Mirik	CBPHCS	1	1																
55	Murshidabad	CBPHCS	1	0																
56	Nabadwip	CBPHCS	1	0		2														
57	Nalhati	CBPHCS	1	0																
58	Old Malda	CBPHCS	1	0																
59	Panskura	CBPHCS	1	1																
60	Purulia	HHW Scheme	1	0																

Sl. No.	ULBs	Programme	Manpower at ULB Level for Management & Supervis																	
			HO		AHO		MO		PHN		SI		Comp. Asst		Accts. Asst					
			S	E	S	E	S	E	S	E	S	E	S	E	S	E				
61	Raghunathpur	CBPHCS	1	1						1	0	1	0			1	1			
62	Ranjibanpur	CBPHCS	1	1						1	1	1	1			1	1			
63	Rampurhat	CBPHCS	1	0			1	0		1	1	1	1			1	1			
64	Ranaghat	CBPHCS	1	1			1	1		1	1	1	0			1	0			
65	Asansol (Raniganj)	CBPHCS	1	0			2	1		1	1	1	1			1	1			
66	Sainthia	CBPHCS	1	0						1	0	1	1			1	1			
67	Santipur	CBPHCS	1	0			2			1	0	1	1			1	1			
68	Sonamukhi	CBPHCS	1	0				1		1	1	1	0			1	1			
69	Suri	HHW Scheme	1	0			0	0	1	0	0	0		1	0			1	1	
70	Taherpur	CBPHCS	1	1						1	1	1	1			1	1			
71	Taki	CBPHCS	1	1						1	1	1	1			1	1			
72	Tamluk	CBPHCS	1	1			1	1		1	1	1	0			1	1			
73	Tarakeshwar	CBPHCS	1	1						1	1	1	1			1	1			
74	Tufanganj	CBPHCS	1	1						1	1	1	1			1	1			
	<b>Total=&gt;</b>		<b>74</b>	<b>35</b>	<b>4</b>	<b>2</b>	<b>43</b>	<b>13</b>	<b>11</b>	<b>10</b>	<b>63</b>	<b>46</b>	<b>63</b>	<b>49</b>	<b>11</b>	<b>8</b>	<b>63</b>	<b>58</b>	<b>11</b>	<b>10</b>

S = Sanctioned  
E = Existing

**ULB-wise Sanctioned & Existing  
Manpower under CBPHCS and HHW**

Sl. No.	ULBs	Programme	ion						Existing Total Manpower		
			Clerk			Health Asst.		CDO		GDA 3000	
			S	E	S	E	S	E			
1	Aranbag	CBPHCS	1	1			1	1			28
2	Ashokenagar	CBPHCS	1	1			1	1			53
3	Baduria	CBPHCS	1	1			1	1			27
4	Bangaon	CBPHCS	1	1			1	1			46
5	Bankura	HHW Scheme			1		0	0	1	1	47
6	Basirhat	CBPHCS	1	1			1	1			49
7	Beldanga	CBPHCS	1	1			1	1			21
8	Berhampur	HHW Scheme			1		0	0	1	1	59
9	Birnagar	CBPHCS	1	1			1	0			22
10	Bishnupur	HHW Scheme			1		0	0	1	1	29
11	Bolpur	HHW Scheme			1		0	0	1	1	28
12	Chakdah	CBPHCS	1	1			1	1			31
13	Chandrakona	CBPHCS	1	1			1	0			20
14	Contai	CBPHCS	1	1			1	1			36
15	Cooch Behar	HHW Scheme			1		0	0	1	1	30
16	Coopers Camp	CBPHCS	1	1			1	1			21
17	Dainhat	CBPHCS	1	1			1	1			22
18	Dalkhola	CBPHCS	1	1			1	1			19
19	Dhulian	CBPHCS	1	1			1	1			26
20	Dhupguri	CBPHCS	1	1			1	1			24
21	Diamond Harbour	CBPHCS	1	1			1	1			25
22	Dinhat	CBPHCS	1	1			1	1			25
23	Dubrajpur	CBPHCS	1	1			1	1			25
24	Egra	CBPHCS	1	1			1	1			23
25	Gangarampur	CBPHCS	1	1			1	1			26
26	Ghatal	CBPHCS	1	1			1	1			26
27	Gobardanga	CBPHCS	1	1			1	0			25
28	Gushkara	CBPHCS	1	1			1	1			24
29	Habra	CBPHCS	1	1			1	1			52
30	Haldia	CBPHCS	1	1			1	0			58

Sl. No.	ULBs	Programme	ion												Existing Total Manpower
			Clerk						Health Asst.		CDO		GDA		
			S	E	S	E	S	E	S	E	S	E			
31	Haldibari	CBPHCS	1	1			1	1						18	
32	Islampur	CBPHCS	1	1			1	1						27	
33	Asansol (Jamuria)	CBPHCS	1	1			1	1						40	
34	Jangipur	HHW Scheme			1		0	0	1	0	1			30	
35	Jaynagar Mazilpur	CBPHCS	1	1			1	1						23	
36	Jhalda	CBPHCS	1	1			1	1						21	
37	Jhargram	CBPHCS	1	1			1	1						27	
38	Jiaganj Azimganj	CBPHCS	1	1			1	1						28	
39	Kaliaganj	CBPHCS	1	1			1	1						26	
40	Kalimpong	CBPHCS	1	0			1	0						26	
41	Kalna	HHW Scheme			1		0	0	1	1	1			32	
42	Kandi	CBPHCS	1	1			1	1						20	
43	Katwa	CBPHCS	1	1			1	1						33	
44	Kharar	CBPHCS	1	1			1	1						17	
45	Khirpai	CBPHCS	1	1			1	0						16	
46	Krishnagar	HHW Scheme			1		0	0	1	0	1			52	
47	Asansol (Kulti)	CBPHCS	1				1							0	
48	Kurseong	CBPHCS	1	1			1	1						29	
49	Mal	CBPHCS	1	1			1	1						26	
50	Mathabhanga	CBPHCS	1	1			1	1						19	
51	Medinipur	HHW Scheme			1		0	0	1	0	1			53	
52	Mekhliganj	CBPHCS	1	1			1	0						15	
53	Memari	CBPHCS	1	1			1	1						23	
54	Mirik	CBPHCS	1	1			1	1						15	
55	Murshidabad	CBPHCS	1	1			1	1						18	
56	Nabadwip	CBPHCS	1	1			1	1						52	
57	Nalhati	CBPHCS	1	1			1	1						26	
58	Old Malda	CBPHCS	1	1			1	1						28	
59	Panskura	CBPHCS	1	1			1	1						27	
60	Purulia	HHW Scheme			1		0	0	1	0	1			39	

Sl. No.	ULBs	Programme	Clerk		Health Asst.		CDO		GDA		Existing Total Manpower		
			S	E	S	E	S	E	S	E			
61	Raghunathpur	CBPHCS	1	1		1	1				19		
62	Ranjibanpur	CBPHCS	1	1		1	1				20		
63	Rampurhat	CBPHCS	1	1		1	0				25		
64	Ranaghat	CBPHCS	1	0		1	0				25		
65	Asansol (Raniganj)	CBPHCS	1	1		1	1				47		
66	Sainthia	CBPHCS	1	1		1	1				24		
67	Santipur	CBPHCS	1	1		1	1				57		
68	Sonamukhi	CBPHCS	1	1		1	1				23		
69	Suri	HHW Scheme			1	0	0	1	1	1	25		
70	Taherpur	CBPHCS	1	1		1	1				19		
71	Taki	CBPHCS	1	1		1	1				26		
72	Tamluk	CBPHCS	1	0		1	1				32		
73	Tarakeshwar	CBPHCS	1	1		1	1				23		
74	Tufanganj	CBPHCS	1	1		1	1				21		
	<b>Total =&gt;</b>		<b>63</b>	<b>59</b>	<b>11</b>	<b>0</b>	<b>63</b>	<b>53</b>	<b>11</b>	<b>7</b>	<b>11</b>	<b>0</b>	<b>2139</b>

S = Sanctioned  
E = Existing

## STATE URBAN DEVELOPMENT AGENCY

“ইলগাস ভবন”, এইচ-সি ব্লক, সেক্টর-৩, বিধাননগর, কলকাতা-৭০০ ১০৬, পশ্চিমবঙ্গ  
“ILGUS BHAVAN”, H-C Block, Sector - III, Bidhannagar, Kolkata - 700 106, West Bengal

ক্রমিক নং ..... SUDA-67/2006(Pt.-III)/16/11(72)

তারিখ ..... 07.06.2019.....

**MEMORANDUM**

Funds are hereby released electronically in favour of Urban Local Bodies towards Honorarium / Salaries April and May, 2019 (including Salary of H.O by taking Dearness Allowance @ 242%) of F.Y 2018-19 as per details shown in the following page for implementation of Community Based Primary Health Care Services (CBPHCS) and HHW Scheme.

Statement of Expenditure (SOE) and Utilization (UC) may please be sent immediately after the cumulative funds on this component released in your favour is utilized.

Enclo. : As stated.

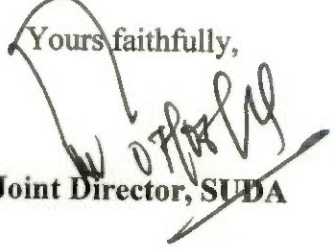
Yours faithfully,  
  
Joint Director, SUDA



Sl. No.	Name of ULB	Honorarium & Salaries	Payee Treasury code	Operator code of Payee	Scheme ID of the payee operator	Scheme description of payee operator
1	Arambag	300664	HGC	14	22119	CBPHCS
2	Asansol (Jamuria)	365890	BUD	1	22260	CBPHCS
	Asansol (Raniganj)	356312	BUD	1	22260	CBPHCS
3	Ashokenagar Kalyangarh	482370	NPA	11	22093	CBPHCS
4	Baduria	294414	NPE	4	22155	CBPHCS
5	Bangaon	414442	NPF	2	22289	CBPHCS
6	Bankura	345312	BAA	26	22192	CBPHCS
7	Basirhat	369664	NPE	3	22155	CBPHCS
8	Beldanga	246686	MUA	20	22184	CBPHCS
9	Berhampur	436414	MUA	18	22184	CBPHCS
10	Birnagar	253362	NAD	21	22099	CBPHCS
11	Bishnupur	227908	BAB	10	22024	CBPHCS
12	Bolpur	220158	BRB	2	22479	CBPHCS
13	Chakdah	331290	NAC	15	22068	CBPHCS
14	Chandrakona	240862	MIC	9	22339	CBPHCS
15	Contai	342964	MIB	2	22387	CBPHCS
16	Coopers Camp	256488	NAD	23	22099	CBPHCS
17	Cooch Behar	214456	COA	12	22525	CBPHCS
18	Dainhat	186908	BUG	7	22003	CBPHCS
19	Dalkhola	158782	UDA	23	22049	CBPHCS
20	Dhulian	202134	MUC	10	22245	CBPHCS
21	Dhupguri	189208	JAA	57	22134	CBPHCS
22	Diamond Harbour	206084	SPC	12	22267	CBPHCS
23	Dinhata	271288	COC	5	22239	CBPHCS
24	Dubrajpur	271288	BRA	24	22050	CBPHCS
25	Egra	268988	PMD	3	22196	CBPHCS
26	Gangarampur	202958	DDC	5	22036	CBPHCS
27	Ghatal	288164	MIC	6	22339	CBPHCS
28	Gobardanga	272538	NPA	10	22093	CBPHCS
29	Gushkara	190458	BUA	18	22362	CBPHCS
30	Habra	376538	NPA	9	22093	CBPHCS
31	Haldia	416964	MID	20	22013	CBPHCS
32	Haldibari	152532	COE	3	22224	CBPHCS
33	Islampur	294414	UDA	7	22049	CBPHCS
34	Jangipur	212206	MUC	9	22245	CBPHCS
35	Jaynagar Mazilpur	268988	SPD	7	22181	CBPHCS
36	Jhalda	256488	PUC	1	22031	CBPHCS
37	Jhargram	283788	MIE	9	22106	CBPHCS
38	Jiaganj Azimganj	312540	MUE	9	22312	CBPHCS
39	Kalimpong	268988	DAC	4	22140	CBPHCS
40	Kaliaganj	212206	UDB	14	22207	CBPHCS
41	Kalna	256488	BUF	7	22994	CBPHCS
42	Kandi	283788	MUD	11	22535	CBPHCS
43	Katwa	312540	BUG	6	22003	CBPHCS
44	Kharar	212206	MIC	7	22339	CBPHCS
45	Khirpai	268988	MIC	8	22339	CBPHCS
46	Krishnagar	256488	NAA	13	22149	CBPHCS
47	Kurseong	296288	DAB	11	22527	CBPHCS
48	Mal	288164	JAD	4	22214	CBPHCS
49	Mathabhanga	225236	COD	14	22133	CBPHCS
50	Medinipur	353660	MIA	14	22304	CBPHCS

Sl. No.	Name of ULB	Honorarium & Salaries	Payee Treasury code	Operator code of Payee	Scheme ID of the payee operator	Scheme description of payee operator
51	Memari	250662	BUA	19	22362	CBPHCS
52	Mekhliganj	133356	COE	2	22224	CBPHCS
53	Mirik	207936	DAF	1	22454	CBPHCS
54	Murshidabad	150004	MUE	7	22312	CBPHCS
55	Nabadwip	388414	NAA	3	22149	CBPHCS
56	Nalhati	224210	BRC	11	22086	CBPHCS
57	Old Malda	214208	MDB	3	22176	CBPHCS
58	Panskura	294414	MIG	26	22069	CBPHCS
59	Purulia	270558	PUA	20	22377	CBPHCS
60	Raghunathpur	223560	PUB	7	22112	CBPHCS
61	Rampurhat	196780	BRC	10	22086	CBPHCS
62	Ramjibanpur	250238	MIC	10	22339	CBPHCS
63	Ranaghat	256286	NAD	19	22099	CBPHCS
64	Santipur	396736	NAD	20	22099	CBPHCS
65	Sonamukhi	195658	BAA	28	22192	CBPHCS
66	Sainthia	189208	BRA	26	22050	CBPHCS
67	Suri	181780	BRA	22	22050	CBPHCS
68	Taherpur	243988	NAD	22	22099	CBPHCS
69	Taki	288164	NPE	5	22155	CBPHCS
70	Tamluk	319214	MIG	36	22039	CBPHCS
71	Tarakeswar	268562	HGD	7	22081	CBPHCS
72	Tufanganj	256488	COF	4	22280	CBPHCS

Memo No. .. SUDA-67/2006(Pt.-III)/16/11(72)/1(2)

Dt. .. 07.06.2019

CC

1. The Mayor / Chairman, ..... MC / Municipality
2. The CPHO (Offg.), SUDA

sd/-  
Joint Director, SUDA

Operator Code : 19

Operator Designation : DIRECTOR, SUDA

Head of Account : 00-8448-00-120-00-013-0-23-00

Local Advice Id : 19

Memo No. : SUDA-67/2006(PT-3)/16/3692

Local Advice Date : 31/05/2019

Memo Date : 31/05/2019

For use of the Operator												For use of Treasury/PAO	
Reference No.	Details of Payee Operator			Details of Recipient Operator						Amount(Rs.)	Purpose	Approved	Objected
	Scheme Id of Operator	Scheme Description of Operator	Payee Treasury code	Payee Treasury Name	Operator Code of Payee	Designation of Payee Operator	Scheme Id of Payee Operator	Scheme Description of Payee Operator	Head of Account of the Payee Operator				
20190500000752	21097	COMMUNITY BASED PRIMARY HEATH CARE	HGC	Arambagh	14	CHAIRMAN, A RAMBAGH	22119	CBPHCS	00-8448-00-102-00-001-0-07-00	300664	CBPHCS		
20190500000754	21097	COMMUNITY BASED PRIMARY HEATH CARE	BUD	Asansol-II	1	Mayor, Asansol Municipal	22260	CBPHCS	00-8448-00-102-00-001-0-07-00	722202	CBPHCS		
20190500000755	21097	COMMUNITY BASED PRIMARY HEATH CARE	NPA	Barasat-I	9	CHAIRMAN, HABRA	22093	CBPHCS	00-8448-00-102-00-001-0-07-00	376536	CBPHCS		
20190500000755	21097	COMMUNITY BASED PRIMARY HEATH CARE	NPA	Barasat-I	11	CHAIRMAN, ASHOKNAGA	22093	CBPHCS	00-8448-00-102-00-001-0-07-00	482370	CBPHCS		
20190500000755	21097	COMMUNITY BASED PRIMARY HEATH CARE	NPA	Barasat-I	10	CHAIRMAN, GOBARDANG	22093	CBPHCS	00-8448-00-102-00-001-0-07-00	272536	CBPHCS		
20190500000756	21097	COMMUNITY BASED PRIMARY HEATH CARE	NPE	Basirhat	4	CHAIRMAN, BADURIA	22155	CBPHCS(SUD A)	00-8448-00-102-00-001-0-07-00	294414	CBPHCS		
20190500000756	21097	COMMUNITY BASED PRIMARY HEATH CARE	NPE	Basirhat	3	Chairman, Basirhat	22155	CBPHCS(SUD A)	00-8448-00-102-00-001-0-07-00	369884	CBPHCS		
20190500000756	21097	COMMUNITY BASED PRIMARY HEATH CARE	NPE	Basirhat	5	CHAIRMAN, TAKI	22155	CBPHCS(SUD A)	00-8448-00-102-00-001-0-07-00	289164	CBPHCS		
20190500000759	21097	COMMUNITY BASED PRIMARY HEATH CARE	NPF	Bongaon	2	CHAIRMAN, BONGAON	22289	CBPHCS	00-8448-00-102-00-001-0-07-00	414442	CBPHCS		

Pay Rs. 3520996 Rupees(in words) Thirty Five Lakh Twenty Thousand Nine Hundred Ninety Six only as transfer.

Assistant Accountant

Signature of PL/LF/PF/OD Operator

Signature of Joint Signatory

Printed By: DEBARATI DATTA GUPTA

Director  
State Urban Development Agency

Page 1 of 1

PAO-III  
Reference Details

Xfer - To Operator List For Personal Ledger Account/Local Fund Account/Provident Fund Account/Other Deposit Account

Operator Code : 19  
Operator Name : DIRECTOR, SUDA

Head of Account : 00-8448-00-120-00-013-0-23-00

Reference Number : 20190500000752

Net Amount : 300664

Reference Date : 30/05/2019

Status : Reference Generated

Sl. No.	Scheme Id	Scheme Description	Payee Treasury Code	Payee Treasury Name	Payee Operator Code	Payee Operator Name	Payee Scheme Id	Payee Scheme Description	Amount	Purpose
1	21097	COMMUNITY BASED	HGC	Arambagh	14	CHAIRMAN,ARAMB AGH	22119	CBPHCS	300664	CBPHCS

Signature of the Assistant/Accountant



Printed By : DIPANKAR CHOWDHURY

Signature of the Administrator



Printed On : 30/05/2019 3:11 PM

Signature of Joint Signatory

Director

Human Development Agency

PAO-III  
Reference Details  
For

Xfer -To Operator List For Personal Ledger Account/Local Fund Account/Provident Fund Account/Other Deposit Account

Operator Code : 19  
Operator Name : DIRECTOR, SUDA

Head of Account : 00-8448-00-120-00-013-0-23-00

Reference Number : 2019050000754

Net Amount : 722202

Reference Date : 30/05/2019

Status : Reference Generated

Sl. No.	Scheme Id	Scheme Description	Payee Treasury Code	Payee Treasury Name	Payee Operator Code	Payee Operator Name	Payee Scheme Id	Payee Scheme Description	Amount	Purpose
1	21097	COMMUNITY BASED	BUD	Asansol-II	1	Mayor,Asansol Municipal	22260	CBPHCS	722202	CBPHCS

Signature of the Assistant/Accountant

Signature of the Administrator

Signature of Joint Signatory

Printed By : DIPANKAR CHOWDHURY

Printed On : 30/05/2019 3:12 PM

Page 1 of 1

*[Signature]*  
Director  
Suda Urban Development Association

PAO-III  
Reference Details

Xfer -To Operator List For Personal Ledger Account/Local Fund Account/Provident Fund Account/Other Deposit Account

Operator Code : 19  
Operator Name : DIRECTOR, SUDA

Head of Account : 00-8448-00-120-00-013-0-23-00

Reference Number : 20190500000755

Net Amount : 1131446

Reference Date : 30/05/2019

Status : Reference Generated

Sl. No.	Scheme Id	Scheme Description	Payee Treasury Code	Payee Treasury Name	Payee Operator Code	Payee Operator Name	Payee Scheme Id	Payee Scheme Description	Amount	Purpose
1	21097	COMMUNITY BASED	NPA	Barasat-I	11	CHAIRMAN, ASHOKNAGAR.	22093	CBPHCS	482370 /	CBPHCS
2	21097	COMMUNITY BASED	NPA	Barasat-I	10	CHAIRMAN, GOBARDANGA	22093	CBPHCS	272538 /	CBPHCS
3	21097	COMMUNITY BASED	NPA	Barasat-I	9	CHAIRMAN, HABRA	22093	CBPHCS	376538 /	CBPHCS

Signature of the Assistant/Accountant



Signature of the Administrator



Signature of Joint Signatory

Printed By : DIPANKAR CHOWDHURY

Printed On : 30/05/2019 3:16 PM

Director

State Urban Development Agency

Page 1 of 1

PAO-III  
Reference Details

Xier -To Operator List For Personal Ledger Account/Local Fund Account/Provident Fund Account/Other Deposit Account

Operator Code : 19  
Operator Name : DIRECTOR, SUDA

Head of Account : 00-8448-00-120-00-013-0-23-00

Reference Number : 20190500000756

Net Amount : 952242

Reference Date : 30/05/2019

Status : Reference Generated

Sl. No.	Scheme Id	Scheme Description	Payee Treasury Code	Payee Treasury Name	Payee Operator Code	Payee Operator Name	Payee Scheme Id	Payee Scheme Description	Amount	Purpose
1	21097	COMMUNITY BASED	NPE	Basirhat	4	CHAIRMAN, BADURIA	22155	CBPHCS(SUDA)	294414 ✓	CBPHCS
2	21097	COMMUNITY BASED	NPE	Basirhat	5	CHAIRMAN, TAKI MUNICIPALITY	22155	CBPHCS(SUDA)	288164 ✓	CBPHCS
3	21097	COMMUNITY BASED	NPE	Basirhat	3	Chairman, Basirhat Municipality	22155	CBPHCS(SUDA)	369664 ✓	CBPHCS

Signature of the Assistant/Accountant



Signature of the Administrator



Signature of Joint Signatory

Printed By : DIPANKAR CHOWDHURY

Printed On : 30/05/2019 3:22 PM

Page 1 of 1

PAO-III  
Reference Details

For  
Xfer -To Operator List For Personal Ledger Account/Local Fund Account/Provident Fund Account/Other Deposit Account

Operator Code : 19

Head of Account : 00-8448-00-120-00-013-0-23-00

Operator Name : DIRECTOR, SUDA

Reference Number : 20190500000759

Net Amount :

414442

Reference Date : 30/05/2019

Status : Reference Generated

Sl. No.	Scheme Id	Scheme Description	Payee Treasury Code	Payee Treasury Name	Payee Operator Code	Payee Operator Name	Payee Scheme Id	Payee Scheme Description	Amount	Purpose
1	21097	COMMUNITY BASED	NPF	Bongaon	2	CHAIRMAN, BONGAON	22289	CBPHCS	414442 /	CBPHCS

Signature of the Assistant/Accountant



Signature of the Administrator



Signature of Joint Signatory

Printed By : DIPANKAR CHOWDHURY

Printed On : 30/05/2019 3:25 PM

Director

Santa Ihsan Development Agency



Operator Code : 19

Operator Designation : DIRECTOR, SUDA

Head of Account : 00-8448-00-120-00-013-0-23-00

Local Advice Id : 20

Memo No. : SUDA-67/2008(PT-3)/16/3693

Local Advice Date : 31/05/2019

Memo Date : 31/05/2019

For use of the Operator											For use of Treasury/PAO		
Reference No.	Details of Payee Operator		Details of Recipient Operator							Amount(Rs.)	Purpose	Approved	Objected
	Scheme Id of Operator	Scheme Description of Operator	Payee Treasury code	Payee Treasury Name	Operator Code of Payee	Designation of Payee Operator	Scheme Id of Payee Operator	Scheme Description of Payee Operator	Head of Account of the Payee Operator				
20190500000761	21097	COMMUNITY BASED PRIMARY HEATH CARE	BAA	Bankura	28	CHAIRMAN, BANKURA	22182	COMMUNITY BASED	00-8448-00-102-00-001-0-07-00	345312	CBPHCS		
20190500000761	21097	COMMUNITY BASED PRIMARY HEATH CARE	BAA	Bankura	28	CHAIRMAN, SONAMUKHI	22182	COMMUNITY BASED	00-8448-00-102-00-001-0-07-00	196658	CBPHCS		
20190500000762	21097	COMMUNITY BASED PRIMARY HEATH CARE	MUA	Berhampore	20	CHAIRMAN BELDANGA	22184	CBPHCS	00-8448-00-102-00-001-0-07-00	246686	CBPHCS		
20190500000762	21097	COMMUNITY BASED PRIMARY HEATH CARE	MUA	Berhampore	18	CHAIRMAN BERTHAMPOR	22184	CBPHCS	00-8448-00-102-00-001-0-07-00	436414	CBPHCS		
20190500000763	21097	COMMUNITY BASED PRIMARY HEATH CARE	NAD	Ranaghat	21	Chairman, Birnagar	22089	CBPHCS	00-8448-00-102-00-001-0-07-00	253362	CBPHCS		
20190500000763	21097	COMMUNITY BASED PRIMARY HEATH CARE	NAD	Ranaghat	19	Chairman, Ranaghat	22089	CBPHCS	00-8448-00-102-00-001-0-07-00	256296	CBPHCS		
20190500000763	21097	COMMUNITY BASED PRIMARY HEATH CARE	NAD	Ranaghat	23	Chairman, Coopers Camp	22089	CBPHCS	00-8448-00-102-00-001-0-07-00	256488	CBPHCS		
20190500000763	21097	COMMUNITY BASED PRIMARY HEATH CARE	NAD	Ranaghat	20	Chairman, Santipur	22089	CBPHCS	00-8448-00-102-00-001-0-07-00	396736	CBPHCS		
20190500000763	21097	COMMUNITY BASED PRIMARY HEATH CARE	NAD	Ranaghat	22	Chairman, Taherpur,	22089	CBPHCS	00-8448-00-102-00-001-0-07-00	243988	CBPHCS		
20190500000764	21097	COMMUNITY BASED PRIMARY HEATH CARE	BAB	Blehnpur	10	CHAIRMAN BISHNUPUR	22024	CBPHCS	00-8448-00-102-00-001-0-07-00	227908	CBPHCS		
20190500000765	21097	COMMUNITY BASED PRIMARY HEATH CARE	BRB	Bolpur	2	CHAIRMAN, BOLPUR	22479	CBPHCS(SUDA)	00-8448-00-102-00-001-0-07-00	220158	CBPHCS		

Pay Rs. 3078996 Rupees(in words) Thirty Lakh Seventy Eight Thousand Nine Hundred Ninety Six only as transfer.



Assistant/Accountant

Signature of PL/LF/PF/OD Operator



Signature of Joint Signatory

Printed By: DEBARATI DATTA GUPTA

State Urban Development Agency

Page 1 of 1

PAO-III  
Reference Details

Xfer - To Operator List For Personal Ledger Account/Local Fund Account/Provident Fund Account/Other Deposit Account

Operator Code : 19

Head of Account : 00-8448-00-120-00-013-0-23-00

Operator Name : DIRECTOR, SUDA

Reference Number : 20190500000761

Net Amount :

540970

Reference Date : 30/05/2019

Status : Reference Generated

Sl. No.	Scheme Id	Scheme Description	Payee Treasury Code	Payee Treasury Name	Payee Operator Code	Payee Operator Name	Payee Scheme Id	Payee Scheme Description	Amount	Purpose
1	21097	COMMUNITY BASED	BAA	Bankura	28	CHAIRMAN, SONAMUKHI	22192	COMMUNITY BASED PRIMARY HEALTH CARE SERVICES	195658 ✓	CBPHCS
2	21097	COMMUNITY BASED	BAA	Bankura	26	CHAIRMAN, BANKURA	22192	COMMUNITY BASED PRIMARY HEALTH CARE SERVICES	345312 ✓	CBPHCS

Signature of the Assistant/Accountant



Signature of the Administrator

Signature of Joint Signatory

Printed By : DIPANKAR CHOWDHURY

Printed On : 30/05/2019 3:38 PM



Director

State Urban Development Agency

PAO-III  
Reference Details

For

Xfer -To Operator List For Personal Ledger Account/Local Fund Account/Provident Fund Account/Other Deposit Account

Operator Code : 19

Head of Account : 00-8448-00-120-00-013-0-23-00

Operator Name : DIRECTOR, SUDA

Reference Number : 20190500000762

Net Amount :

683100

Reference Date : 30/05/2019

Status : Reference Generated

Sl. No.	Scheme Id	Scheme Description	Payee Treasury Code	Payee Treasury Name	Payee Operator Code	Payee Operator Name	Payee Scheme Id	Payee Scheme Description	Amount	Purpose
1	21097	COMMUNITY BASED	MUA	Berhampor e-I	18	CHAIRMAN BERHAMPORE	22184	CBPHCS	436414 /	CBPHCS
2	21097	COMMUNITY BASED	MUA	Berhampor e-I	20	CHAIRMAN BELDANGA	22184	CBPHCS	246686 /	CBPHCS

Signature of the Assistant/Accountant

Signature of the Administrator

Signature of Joint Signatory

Printed By : DIPANKAR CHOWDHURY

Printed On : 30/05/2019 3:40 PM

Page 1 of 1

State Urban Development Agency  
Director

PAO-III  
Reference Details

Xfer -To Operator List For Personal Ledger Account/Local Fund Account/Provident Fund Account/Other Deposit Account

Operator Code : 19  
Operator Name : DIRECTOR, SUDA

Head of Account : 00-8448-00-120-00-013-0-23-00

Reference Number : 20190500000763

Net Amount : 1406860

Reference Date : 30/05/2019

Status : Reference Generated

Sl. No.	Scheme Id	Scheme Description	Payee Treasury Code	Payee Treasury Name	Payee Operator Code	Payee Operator Name	Payee Scheme Id	Payee Scheme Description	Amount	Purpose
1	21097	COMMUNITY BASED	NAD	Ranaghat	21	Chairman, Birnagar Municipality	22099	CBPHCS	253362 /	CBPHCS
2	21097	COMMUNITY BASED	NAD	Ranaghat	19	Chairman, Ranaghat Municipality.	22099	CBPHCS	256286 /	CBPHCS
3	21097	COMMUNITY BASED	NAD	Ranaghat	23	Chairman, Coopers Camp Notified Area	22099	CBPHCS	256488 /	CBPHCS
4	21097	COMMUNITY BASED	NAD	Ranaghat	22	Chairman, Taherpur, Notified Area	22099	CBPHCS	243988 /	CBPHCS
5	21097	COMMUNITY BASED	NAD	Ranaghat	20	Chairman, Santipur Municipality	22099	CBPHCS	396736 /	CBPHCS

Signature of the Assistant/Accountant

Signature of the Administrator

Signature of Joint Signatory

Printed By : DIPANKAR CHOWDHURY

Printed On : 30/05/2019 3:44 PM

Director

Public Urban Development Agency

Page 1 of 1

PAO-III  
Reference Details

For  
Xfer - To Operator List For Personal Ledger Account/Local Fund Account/Provident Fund Account/Other Deposit Account

Head of Account : 00-8448-00-120-00-013-0-23-00

Operator Code : 19

Operator Name : DIRECTOR, SUDA

Net Amount :

227908

Reference Number : 20190500000764

Reference Date : 30/05/2019

Status : Reference Generated

Sl. No.	Scheme Id	Scheme Description	Payee Treasury Code	Payee Treasury Name	Payee Operator Code	Payee Operator Name	Payee Scheme Id	Payee Scheme Description	Amount	Purpose
1	21097	COMMUNITY BASED	BAB	Bishnupur	10	CHAIRMAN BISHNUPUR	22024	CBPHCS	227908 /	CBPHCS

Signature of the Assistant/Accountant

Printed By : DIPANKAR CHOWDHURY

Signature of the Administrator

Printed On : 30/05/2019 3:46 PM

Signature of Joint Signatory

PAO-III  
Reference Details

Xfer - To Operator List For Personal Ledger Account/Local Fund Account/Provident Fund Account/Other Deposit Account

Operator Code : 19

Head of Account : 00-8448-00-120-00-013-0-23-00

Operator Name : DIRECTOR, SUDA

Reference Number : 20190500000765

Net Amount : 220158

Reference Date : 30/05/2019

Status : Reference Generated

Sl. No.	Scheme Id	Scheme Description	Payee Treasury Code	Payee Treasury Name	Payee Operator Code	Payee Operator Name	Payee Scheme Id	Payee Scheme Description	Amount	Purpose
1	21097	COMMUNITY BASED	BRB	Bolpur	2	CHAIRMAN, BOLPUR	22479	CBPHCS(SUDA)	220158 /	CBPHCS

Signature of the Assistant/Accountant



Signature of the Administrator



Signature of Joint Signatory

Printed By : DIPANKAR CHOWDHURY

Printed On : 30/05/2019 3:47 PM

State Urban Development Agency  
Director

## PAO-III

## e-Advice For Personal Ledger Account/Local Fund Account/Provident Fund Account/Other Deposit Account

(For Transfer from one Operator to another Operator)

Operator Code : 19

Operator Designation : DIRECTOR, SUDA

Head of Account : 00-8448-00-120-00-013-0-23-00

Local Advice Id : 21

Memo No. : SUDA-87/2008(PT-3)/16/3694

Local Advice Date : 31/05/2019

Memo Date : 31/05/2019

## For use of the Operator

Reference No.	Details of Payee Operator		Details of Recipient Operator							Amount(Rs.)	Purpose	For use of Treasury/PAO	
	Scheme Id of Operator	Scheme Description of Operator	Payee Treasury code	Payee Treasury Name	Operator Code of Payee	Designation of Payee Operator	Scheme Id of Payee Operator	Scheme Description of Payee Operator	Head of Account of the Payee Operator			Approved	Objected
2019050000765	21097	COMMUNITY BASED PRIMARY HEATH CARE	NAC	Kalyani	15	CHAIRMAN, CHAKDAHA	22088	CBPHCS	00-8448-00-102-00-001-0-07-00	331290	CBPHCS		
2019050000767	21097	COMMUNITY BASED PRIMARY HEATH CARE	MIC	Ghatal	8	Chairman, Ghatal	22339	CBPHCS	00-8448-00-102-00-001-0-07-00	288164	CBPHCS		
2019050000767	21097	COMMUNITY BASED PRIMARY HEATH CARE	MIC	Ghatal	7	Chairman, Kharar	22339	CBPHCS	00-8448-00-102-00-001-0-07-00	212206	CBPHCS		
2019050000767	21097	COMMUNITY BASED PRIMARY HEATH CARE	MIC	Ghatal	9	Chairman, Chandrakona	22339	CBPHCS	00-8448-00-102-00-001-0-07-00	240862	CBPHCS		
2019050000767	21097	COMMUNITY BASED PRIMARY HEATH CARE	MIC	Ghatal	8	Chairman, Khirpai	22339	CBPHCS	00-8448-00-102-00-001-0-07-00	268988	CBPHCS		
2019050000767	21097	COMMUNITY BASED PRIMARY HEATH CARE	MIC	Ghatal	10	Chairman, Ramjibanpur	22339	CBPHCS	00-8448-00-102-00-001-0-07-00	250238	CBPHCS		
2019050000768	21097	COMMUNITY BASED PRIMARY HEATH CARE	MIB	Contal	2	CHAIRMAN CONTAL	22387	CBPHCS	00-8448-00-102-00-001-0-07-00	342964	CBPHCS		
2019050000769	21097	COMMUNITY BASED PRIMARY HEATH CARE	COA	Cooch Behar-I	12	Chairman, Cooch Behar	22525	CBPHCS	00-8448-00-102-00-001-0-07-00	214458	CBPHCS		
2019050000770	21097	COMMUNITY BASED PRIMARY HEATH CARE	BUG	Katwa	7	CHAIRMAN DAINHAT	22003	CBPHCS	00-8448-00-102-00-001-0-07-00	186908	CBPHCS		
2019050000770	21097	COMMUNITY BASED PRIMARY HEATH CARE	BUG	Katwa	6	CHAIRMAN KATWA	22003	CBPHCS	00-8448-00-102-00-001-0-07-00	312540	CBPHCS		

Pay Rs. 2648616 Rupees(in words) Twenty Six Lakh Forty Eight Thousand Six Hundred Sixteen only as transfer.



Assistant/Accountant

Signature of PULF/PF/OD Operator

Signature of Joint Signatory

Printed By: DEBARATI DATTA GUPTA



Director

State Urban Development Agency

Page 1 of 1

PAO-III  
Reference Details

Xfer -To Operator List For Personal Ledger Account/Local Fund Account/Provident Fund Account/Other Deposit Account

For

Operator Code : 19

Head of Account : 00-8448-00-120-00-013-0-23-00

Operator Name : DIRECTOR, SUDA

Reference Number : 2019050000766

Net Amount : 331290

Reference Date : 30/05/2019

Status : Reference Generated

Sl. No.	Scheme Id	Scheme Description	Payee Treasury Code	Payee Treasury Name	Payee Operator Code	Payee Operator Name	Payee Scheme Id	Payee Scheme Description	Amount	Purpose
1	21097	COMMUNITY BASED	NAC	Kalyani	15	CHAIRMAN, CHAKDAHHA	22068	CBPHCS	331290 /	CBPHCS

Signature of the Assistant/Accountant

Printed By : DIPANKAR CHOWDHURY

Signature of the Administrator

Printed On : 30/05/2019 3:48 PM

Signature of Joint Signatory

Page 1 of 1



PAO-III  
Reference Details  
For

Xfer -To Operator List For Personal Ledger Account/Local Fund Account/Provident Fund Account/Other Deposit Account

Operator Code : 19

Head of Account : 00-8448-00-120-00-013-0-23-00

Operator Name : DIRECTOR, SUDA

Reference Number : 2019050000767

Net Amount : 1260458

Reference Date : 30/05/2019

Status : Reference Generated

Sl. No.	Scheme Id	Scheme Description	Payee Treasury Code	Payee Treasury Name	Payee Operator Code	Payee Operator Name	Payee Scheme Id	Payee Scheme Description	Amount	Purpose
1	21097	COMMUNITY BASED	MIC	Ghatal	9	Chairman, Chandrakona	22339	CBPHCS	240862 ✓	CBPHCS
2	21097	COMMUNITY BASED	MIC	Ghatal	6	Chairman, Ghatal Municipality	22339	CBPHCS	288164 ✓	CBPHCS
3	21097	COMMUNITY BASED	MIC	Ghatal	10	Chairman, Ramjibanpur	22339	CBPHCS	250238 ✓	CBPHCS
4	21097	COMMUNITY BASED	MIC	Ghatal	8	Chairman, Khirpai Municipality	22339	CBPHCS	268988 ✓	CBPHCS
5	21097	COMMUNITY BASED	MIC	Ghatal	7	Chairman, Kharar Municipality	22339	CBPHCS	212206 ✓	CBPHCS

Signature of the Assistant/Accountant

Signature of the Administrator

Signature of Joint Signatory

Printed By : DIPANKAR CHOWDHURY

Printed On : 30/05/2019 3:51 PM

Page 1 of 1

Signature

1 of 1

Director  
State Urban Employment Agency

Operator Code : 19

Operator Designation : DIRECTOR, SUDA

Head of Account : 00-8448-00-120-00-013-0-23-00

Local Advice Id : 22

Memo No. : SUDA-67/2006(PT-3)/16/3695

Local Advice Date : 31/05/2019

Memo Date : 31/05/2019

## For use of the Operator

For use of  
Treasury/PAO

Reference No.	Details of Payee Operator		Details of Recipient Operator							Amount(Rs.)	Purpose	Approved	Objected
	Scheme Id of Operator	Scheme Description of Operator	Payee Treasury code	Payee Treasury Name	Operator Code of Payee	Designation of Payee Operator	Scheme Id of Payee Operator	Scheme Description of Payee Operator	Head of Account of the Payee Operator				
2019050000771	21097	COMMUNITY BASED PRIMARY HEATH CARE	UDA	Islampur	23	Chairman, Dalkhola	22049	COMMUNITY BASED	00-8448-00-102-00-001-0-07-00	158782	CBPHCS		
2019050000771	21097	COMMUNITY BASED PRIMARY HEATH CARE	UDA	Islampur	7	Chairman, Islampur	22049	COMMUNITY BASED	00-8448-00-102-00-001-0-07-00	294414	CBPHCS		
2019050000772	21097	COMMUNITY BASED PRIMARY HEATH CARE	MUC	Jangipur	10	DHULIYAN MUNICIPALIT	22245	CBPHCS	00-8448-00-102-00-001-0-07-00	202134	CBPHCS		
2019050000772	21097	COMMUNITY BASED PRIMARY HEATH CARE	MUC	Jangipur	9	JANGIPUR MUNICIPALIT	22245	CBPHCS	00-8448-00-102-00-001-0-07-00	212206	CBPHCS		
2019050000773	21097	COMMUNITY BASED PRIMARY HEATH CARE	JAM	Jaipalguri-I	57	Chairman, Dnugguri	22134	CBPHCS	00-8448-00-102-00-001-0-07-00	189208	CBPHCS		
2019050000774	21097	COMMUNITY BASED PRIMARY HEATH CARE	SPC	Diamond Harbour	12	DIAMOND HARBOUR	22267	CBPHCS	00-8448-00-102-00-001-0-07-00	206084	CBPHCS		
2019050000776	21097	COMMUNITY BASED PRIMARY HEATH CARE	COC	Dinhata	5	Chairman Dinhata	22239	CBPHCS	00-8448-00-102-00-001-0-07-00	271288	CBPHCS		

Pay Rs. 1534116 Rupees(in words) Fifteen Lakh Thirty Four Thousand One Hundred Sixteen only as transfer.



Assistant/Accountant

Signature of PL/LF/PF/OD Operator



Signature of Joint Signatory

Printed By: DEBARATI DATTA GUPTA



Page 1 of 1

PAO-III  
Reference Details  
For

Xfer -To Operator List For Personal Ledger Account/Local Fund Account/Provident Fund Account/Other Deposit Account

Operator Code : 19

Head of Account : 00-8448-00-120-00-013-0-23-00

Operator Name : DIRECTOR, SUDA

Reference Number : 2019050000767

Net Amount : 1260458

Reference Date : 30/05/2019

Status : Reference Generated

Sl. No.	Scheme Id	Scheme Description	Payee Treasury Code	Payee Treasury Name	Payee Operator Code	Payee Operator Name	Payee Scheme Id	Payee Scheme Description	Amount	Purpose
1	21097	COMMUNITY BASED	MIC	Ghatal	9	Chairman, Chandrakona	22339	CBPHCS	240862 ✓	CBPHCS
2	21097	COMMUNITY BASED	MIC	Ghatal	6	Chairman, Ghatal Municipality	22339	CBPHCS	288164 ✓	CBPHCS
3	21097	COMMUNITY BASED	MIC	Ghatal	10	Chairman, Ramjibanpur	22339	CBPHCS	250238 ✓	CBPHCS
4	21097	COMMUNITY BASED	MIC	Ghatal	8	Chairman, Khirpai Municipality	22339	CBPHCS	268988 ✓	CBPHCS
5	21097	COMMUNITY BASED	MIC	Ghatal	7	Chairman, Kharar Municipality	22339	CBPHCS	212206 ✓	CBPHCS

Signature of the Assistant/Accountant

Signature of the Administrator

Signature of Joint Signatory

Printed By : DIPANKAR CHOWDHURY

Printed On : 30/05/2019 3:51 PM

Page 1 of 1

  
Director  
State Urban Development Agency

PAO-III  
Reference Details

For

Xfer -To Operator List For Personal Ledger Account/Local Fund Account/Provident Fund Account/Other Deposit Account

Head of Account : 00-8448-00-120-00-013-0-23-00

Operator Code : 19  
Operator Name : DIRECTOR, SUDA  
Net Amount : 342964

Reference Number : 20190500000768

Reference Date : 30/05/2019

Status : Reference Generated

Sl. No.	Scheme Id	Scheme Description	Payee Treasury Code	Payee Treasury Name	Payee Operator Code	Payee Operator Name	Payee Scheme Id	Payee Scheme Description	Amount	Purpose
1	21097	COMMUNITY BASED	MIB	Contai	2	CHAIRMAN CONTAI	22387	CBPHCS	342964	CBPHCS

Signature of the Administrator

Signature of the Assistant/Accountant

Printed By : DIPANKAR CHOWDHURY

Printed On : 30/05/2019 3:53 PM

Signature of Joint Signatory

Page 1 of 1

*[Handwritten Signature]*  
Director  
State Urban Development Agency

PAO-III  
Reference Details

Xfer -To Operator List For Personal Ledger Account/Local Fund Account/Provident Fund Account/Other Deposit Account

Operator Code : 19  
Operator Name : DIRECTOR, SUDA

Head of Account : 00-8448-00-120-00-013-0-23-00

Reference Number : 20190500000769

Net Amount : 214456

Reference Date : 30/05/2019

Status : Reference Generated

Sl. No.	Scheme Id	Scheme Description	Payee Treasury Code	Payee Treasury Name	Payee Operator Code	Payee Operator Name	Payee Scheme Id	Payee Scheme Description	Amount	Purpose
1	21097	COMMUNITY BASED	COA	Cooch Behar-I	12	Chairman, Coochbeh ar	22525	CBPHCS.	214456	CBPHCS

Signature of the Assistant/Accountant

Signature of the Administrator

Signature of Joint Signatory

Printed By : DIPANKAR CHOWDHURY

Printed On : 30/05/2019 3:54 PM

Page 1 of 1

PAO-III  
Reference Details

Xier - To Operator List For Personal Ledger Account/Local Fund Account/Provident Fund Account/Other Deposit Account

Operator Code : 19

Operator Name : DIRECTOR, SUDA

Head of Account : 00-8448-00-120-00-013-0-23-00

Reference Number : 2019050000770

Net Amount :

499448

Reference Date : 30/05/2019

Status : Reference Generated

Sl. No.	Scheme Id	Scheme Description	Payee Treasury Code	Payee Treasury Name	Payee Operator Code	Payee Operator Name	Payee Scheme Id	Payee Scheme Description	Amount	Purpose
1	21097	COMMUNITY BASED	BUG	Katwa	6	CHAIRMAN KATWA MUNICIPALITY	22003	CBPHCS	312540	CBPHCS
2	21097	COMMUNITY BASED	BUG	Katwa	7	CHAIRMAN DAINHAT	22003	CBPHCS	186908	CBPHCS

Signature of the Assistant/Accountant



Signature of the Administrator



Signature of Joint Signatory

Printed By : DIPANKAR CHOWDHURY

Printed On : 30/05/2019 3:55 PM

State Urban Development Agency

Director

PAO-III  
Reference Details

For

Xfer -To Operator List For Personal Ledger Account/Local Fund Account/Provident Fund Account/Other Deposit Account

Operator Code : 19

Operator Name : DIRECTOR, SUDA

Head of Account : 00-8448-00-120-00-013-0-23-00

Net Amount :

453196

Reference Number : 20190500000771

Reference Date : 30/05/2019

Status : Reference Generated

Sl. No.	Scheme Id	Scheme Description	Payee Treasury Code	Payee Treasury Name	Payee Operator Code	Payee Operator Name	Payee Scheme Id	Payee Scheme Description	Amount	Purpose
1	21097	COMMUNITY BASED	UDA	Islampur	7	Chairman, Islampur Municipality(LF)	22049	COMMUNITY BASED PRIMARY HEALTH CARE SERVICE	294414	CBPHCS
2	21097	COMMUNITY BASED	UDA	Islampur	23	Chairman, Dalkhola Municipality(LF)	22049	COMMUNITY BASED PRIMARY HEALTH CARE SERVICE	158782	CBPHCS

Signature of the Assistant/Accountant

Printed By : DIPANKAR CHOWDHURY

Signature of the Administrator

Printed On : 30/05/2019 3:58 PM

Signature of Joint Signatory

Director

State Urban Development Agency

PAO-III  
Reference Details

For

Xier -To Operator List For Personal Ledger Account/Local Fund Account/Provident Fund Account/Other Deposit Account

Operator Code : 19

Operator Name : DIRECTOR, SUDA

Head of Account : 00-8448-00-120-00-013-0-23-00

Reference Number : 20190500000772

Net Amount :

414340

Reference Date : 30/05/2019

Status : Reference Generated

Sl. No.	Scheme Id	Scheme Description	Payee Treasury Code	Payee Treasury Name	Payee Operator Code	Payee Operator Name	Payee Scheme Id	Payee Scheme Description	Amount	Purpose
1	21097	COMMUNITY BASED	MUC	Jangipur	9	JANGIPUR MUNICIPALITY	22245	CBPHCS	212206	CBPHCS
2	21097	COMMUNITY BASED	MUC	Jangipur	10	DHULYAN MUNICIPALITY	22245	CBPHCS	202134	CBPHCS

Signature of the Assistant/Accountant



Printed By : DIPANKAR CHOWDHURY

Signature of the Administrator

Printed On : 30/05/2019 3:59 PM

Signature of Joint Signatory



Director

State Urban Development Agency



PAO-III  
Reference Details  
For

Xfer - To Operator List For Personal Ledger Account/Local Fund Account/Provident Fund Account/Other Deposit Account

Operator Code : 19  
Operator Name : DIRECTOR, SUDA

Head of Account : 00-8448-00-120-00-013-0-23-00

Reference Number : 20190500000773

Net Amount : 189208

Reference Date : 30/05/2019

Status : Reference Generated

Sl. No.	Scheme Id	Scheme Description	Payee Treasury Code	Payee Treasury Name	Payee Operator Code	Payee Operator Name	Payee Scheme Id	Payee Scheme Description	Amount	Purpose
1	21097	COMMUNITY BASED	JAA	Jalpaiguri-I	57	Chairman, Dhupguri Municipality.	22134	CBPHCS	189208	CBPHCS

Signature of the Assistant/Accountant

Signature of the Administrator

Signature of Joint Signatory

Printed By : DIPANKAR CHOWDHURY

Printed On : 30/05/2019 4:01 PM

Director  
State Urban Development Agency

PAO-III  
Reference Details  
For

Xfer -To Operator List For Personal Ledger Account/Local Fund Account/Provident Fund Account/Other Deposit Account

Operator Code : 19

Head of Account : 00-8448-00-120-00-013-0-23-00

Operator Name : DIRECTOR, SUDA

Reference Number : 20190500000774

Net Amount : 206084

Reference Date : 30/05/2019

Status : Reference Generated

Sl. No.	Scheme Id	Scheme Description	Payee Treasury Code	Payee Treasury Name	Payee Operator Code	Payee Operator Name	Payee Scheme Id	Payee Scheme Description	Amount	Purpose
1	21097	COMMUNITY BASED	SPC	Diamond Harbour	12	DIAMOND HARBOUR	22267	CBPHCS	206084	CBPHCS

Signature of the Assistant/Accountant

Printed By : DIPANKAR CHOWDHURY

Signature of the Administrator

Printed On : 30/05/2019 4:02 PM

Signature of Joint Signatory

Page 1 of 1

Director  
State Urban Development Agency

PAO-III  
Reference Details

For

Xfer - To Operator List For Personal Ledger Account/Local Fund Account/Provident Fund Account/Other Deposit Account

Operator Code : 19

Operator Name : DIRECTOR, SUDA

Head of Account : 00-8448-00-120-00-013-0-23-00

Reference Number : 20190500000776

Reference Date : 30/05/2019

Net Amount :

271288

Status : Reference Generated

Sl. No.	Scheme Id	Scheme Description	Payee Treasury Code	Payee Treasury Name	Payee Operator Code	Payee Operator Name	Payee Scheme Id	Payee Scheme Description	Amount	Purpose
1	21097	COMMUNITY BASED	COC	Dinhata	5	Chairman Dinhata Municipality.	22239	CBPHCS	271288	CBPHCS

Signature of the Assistant/Accountant

Printed By : DIPANKAR CHOWDHURY

Signature of the Administrator

Printed On : 30/05/2019 4:04 PM

Signature of Joint Signatory

Page 1 of 1

Date: 30/05/2019  
Director

e-Advice For Personal Ledger Account/Local Fund Account/Provident Fund Account/Other Deposit Account  
(For Transfer from one Operator to another Operator)

Operator Code : 29

Operator Designation : DIRECTOR, SUDA

Head of Account : 00-8448-00-120-00-013-0-23-00

Local Advice Id : 23

Memo No. : SUDA-67/2006(PT-3)/16/3696

Local Advice Date : 31/05/2019

Memo Date : 31/05/2019

For use of the Operator

For use of  
Treasury/PAO

Reference No.	Details of Payee Operator		Details of Recipient Operator							Amount(Rs.)	Purpose	Approved	Objected
	Scheme Id of Operator	Scheme Description of Operator	Payee Treasury code	Payee Treasury Name	Operator Code of Payee	Designation of Payee Operator	Scheme Id of Payee Operator	Scheme Description of Payee Operator	Head of Account of the Payee Operator				
2019050000777	21097	COMMUNITY BASED PRIMARY HEATH CARE	BRA	Birbhum-I	24	CHAIRMAN DUBRAJPUR	22050	CBPHCS	00-8448-00-102-00-001-0-07-00	271288	CBPHCS		
2019050000777	21097	COMMUNITY BASED PRIMARY HEATH CARE	BRA	Birbhum-I	26	CHAIRMAN SAINTHIA	22050	CBPHCS	00-8448-00-102-00-001-0-07-00	189208	CBPHCS		
2019050000777	21097	COMMUNITY BASED PRIMARY HEATH CARE	BRA	Birbhum-I	22	CHAIRMAN SURI	22050	CBPHCS	00-8448-00-102-00-001-0-07-00	181780	CBPHCS		
2019050000778	21097	COMMUNITY BASED PRIMARY HEATH CARE	PMD	Egra	3	CHAIRMAN EGRA	22196	CBPHCS	00-8448-00-102-00-001-0-07-00	268988	CBPHCS		
2019050000778	21097	COMMUNITY BASED PRIMARY HEATH CARE	DDC	Gangarampu	5	CHAIRMAN, GANGARAMP	22036	CBPHCH	00-8448-00-102-00-001-0-07-00	202958	CBPHCS		
2019050000780	21097	COMMUNITY BASED PRIMARY HEATH CARE	BUA	Burdwan-I	18	CHAIRMAN, G USHKARA	22362	CBPHCS(2018-19)	00-8448-00-102-00-001-0-07-00	190458	CBPHCS		
2019050000780	21097	COMMUNITY BASED PRIMARY HEATH CARE	BUA	Burdwan-I	19	CHAIRMAN, MEMARI	22362	CBPHCS(2018-19)	00-8448-00-102-00-001-0-07-00	250562	CBPHCS		
2019050000782	21097	COMMUNITY BASED PRIMARY HEATH CARE	MID	Haldia	20	CHAIR PERSON	22013	CBPHCS	00-8448-00-102-00-001-0-07-00	416964	CBPHCS		

Pay Rs. 1972306 Rupees(in words) Nineteen Lakh Seventy Two Thousand Three Hundred Six only as transfer.



Assistant/Accountant

Signature of PULF/PF/OD Operator



Signature of Joint Signatory

Printed By: DEBARATI DATTA GUPTA

Director  
Suda Urban Development Agency

Page 1 of 1

PAO-III  
Reference Details

For

Xfer -To Operator List For Personal Ledger Account/Local Fund Account/Provident Fund Account/Other Deposit Account

Operator Code : 19

Operator Name : DIRECTOR, SUDA

Head of Account : 00-8448-00-120-00-013-0-23-00

Reference Number : 20190500000777

Net Amount :

Reference Date : 30/05/2019

642276

Status : Reference Generated

Sl. No.	Scheme Id	Scheme Description	Payee Treasury Code	Payee Treasury Name	Payee Operator Code	Payee Operator Name	Payee Scheme Id	Payee Scheme Description	Amount	Purpose
1	21097	COMMUNITY BASED	BRA	Birbhum-I	24	CHAIRMAN DUBRAJPUR	22050	CBPHCS	271288	CBPHCS
2	21097	COMMUNITY BASED	BRA	Birbhum-I	22	CHAIRMAN SURI MUNICIPALITY(LF)	22050	CBPHCS	181780	CBPHCS
3	21097	COMMUNITY BASED	BRA	Birbhum-I	26	CHAIRMAN SAINTHIA	22050	CBPHCS	189208	CBPHCS

Signature of the Assistant/Accountant

Printed By : DIPANKAR CHOWDHURY

Signature of the Administrator

Printed On : 30/05/2019 4:06 PM



Director

Signature of Joint Signatory

State Urban Development Agency

PAO-III  
Reference Details

Xier -To Operator List For Personal Ledger Account/Local Fund Account/Provident Fund Account/Other Deposit Account

Operator Code : 19  
 Operator Name : DIRECTOR, SUDA  
 Reference Number : 20190500000778  
 Reference Date : 30/05/2019  
 Status : Reference Generated

Head of Account : 00-8448-00-120-00-013-0-23-00  
 Net Amount : 268988

Sl. No.	Scheme Id	Scheme Description	Payee Treasury Code	Payee Treasury Name	Payee Operator Code	Payee Operator Name	Payee Scheme Id	Payee Scheme Description	Amount	Purpose
1	21097	COMMUNITY BASED	PMD	Egra	3	CHAIRMAN EGRA MUNICIPALITY	22196	CBPHCS	268988	CBPHCS

Signature of the Assistant/Accountant

Printed By : DIPANKAR CHOWDHURY

Signature of the Administrator

Printed On : 30/05/2019 4:07 PM



Director

Uttar Development Agency

Signature of Joint Signatory

PAO-III  
Reference Details  
For

Xfer -To Operator List For Personal Ledger Account/Local Fund Account/Provident Fund Account/Other Deposit Account

Operator Code : 19

Head of Account : 00-8448-00-120-00-013-0-23-00

Operator Name : DIRECTOR, SUDA

Reference Number : 2019050000779

Net Amount : 202958

Reference Date : 30/05/2019

Status : Reference Generated

Sl. No.	Scheme Id	Scheme Description	Payee Treasury Code	Payee Treasury Name	Payee Operator Code	Payee Operator Name	Payee Scheme Id	Payee Scheme Description	Amount	Purpose
1	21097	COMMUNITY BASED	DDC	Gangarampur	5	CHAIRMAN, GANGARAMPUR	22036	CBPHCH	202958	CBPHCS

Signature of the Assistant/Accountant

Signature of the Administrator

Signature of Joint Signatory

Printed By : DIPANKAR CHOWDHURY

Printed On : 30/05/2019 4:08 PM

Director

Page 1 of 1

PAO-III  
Reference Details

For

Xfer - To Operator List For Personal Ledger Account/Local Fund Account/Provident Fund Account/Other Deposit Account

Operator Code : 19

Operator Name : DIRECTOR, SUDA

Head of Account : 00-8448-00-120-00-013-0-23-00

Reference Number : 2019050000780

Net Amount :

Reference Date : 30/05/2019

441120

Status : Reference Generated

Sl. No.	Scheme Id	Scheme Description	Payee Treasury Code	Payee Treasury Name	Payee Operator Code	Payee Operator Name	Payee Scheme Id	Payee Scheme Description	Amount	Purpose
1	21097	COMMUNITY BASED	BUA	Burdwan-I	19	CHAIRMAN, MEMARI	22362	CBPHCS(2018-19)	250662 ✓	CBPHCS
2	21097	COMMUNITY BASED	BUA	Burdwan-I	18	CHAIRMAN, GUSHK ARA	22362	CBPHCS(2018-19)	190458 ✓	CBPHCS

Signature of the Assistant/Accountant

Printed By : DIPANKAR CHOWDHURY

Signature of the Administrator

Printed On : 30/05/2019 4:10 PM

Director

Signature of Joint Signatory

2019 05 30 16:10:10



PAO-III  
Reference Details

For  
Xfer -To Operator List For Personal Ledger Account/Local Fund Account/Provident Fund Account/Other Deposit Account

Operator Code : 19

Head of Account : 00-8448-00-120-00-013-0-23-00

Operator Name : DIRECTOR, SUDA

Reference Number : 2019050000782

Net Amount : 416964

Reference Date : 30/05/2019

Status : Reference Generated

Sl. No.	Scheme Id	Scheme Description	Payee Treasury Code	Payee Treasury Name	Payee Operator Code	Payee Operator Name	Payee Scheme Id	Payee Scheme Description	Amount	Purpose
1	21097	COMMUNITY BASED	MID	Halidia	20	CHAIR PERSON HALDIA	22013	CBPHCS	416964	CBPHCS

Signature of the Assistant/Accountant



Signature of the Administrator

Signature of Joint Signatory

Printed By : DIPANKAR CHOWDHURY

Printed On : 30/05/2019 4:12 PM

Page 1 of 1

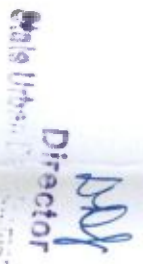
  
Director

## e-Advice For Personal Ledger Account/Local Fund Account/Provident Fund Account/Other Deposit Account

(For Transfer from one Operator to another Operator )

Operator Code : 19

Operator Designation : DIRECTOR, SUDA

Head of Account : 00-8448-00-120-00-013-0-23-00

Local Advice Id : 24

Memo No. : SUDA-67/2006(PT-3)/16/3697

Local Advice Date : 31/05/2019

Memo Date : 31/05/2019

For use of the Operator												For use of Treasury/PAO		
Reference No.	Details of Payee Operator			Details of Recipient Operator							Amount(Rs.)	Purpose	Approved	Objected
	Scheme Id of Operator	Scheme Description of Operator	Payee Treasury code	Payee Treasury Name	Operator Code of Payee	Designation of Payee Operator	Scheme Id of Payee Operator	Scheme Description of Payee Operator	Head of Account of the Payee Operator					
20190500000784	21097	COMMUNITY BASED PRIMARY HEATH CARE	COE	Mekhliganj	3	CHAIRMAN, HALDIBARI	22224	CBPHCS	00-8448-00-102-00-001-0-07-00	152532	CBPHCS			
20190500000784	21097	COMMUNITY BASED PRIMARY HEATH CARE	COE	Mekhliganj	2	CHAIRMAN, MEKHLIGANJ	22224	CBPHCS	00-8448-00-102-00-001-0-07-00	133356	CBPHCS			
20190500000785	21097	COMMUNITY BASED PRIMARY HEATH CARE	SPD	Barulpur	7	CHAIRMAN J OYNAGAR	22161	CBPHCS	00-8448-00-102-00-001-0-07-00	268988	CBPHCS			
20190500000786	21097	COMMUNITY BASED PRIMARY HEATH CARE	PUC	Jhalda	1	CHAIRMAN, JHALDA	22031	CBPHCS	00-8448-00-102-00-001-0-07-00	256486	CBPHCS			
20190500000787	21097	COMMUNITY BASED PRIMARY HEATH CARE	MIE	Jhargram	9	CHAIRMAN, JHARGRAM	22106	CBPHCS	00-8448-00-102-00-001-0-07-00	283788	CBPHCS			
20190500000788	21097	COMMUNITY BASED PRIMARY HEATH CARE	MUE	Lalbagh	9	CHAIRMAN, JAGANJ	22312	CBPHCS	00-8448-00-102-00-001-0-07-00	312540	CBPHCS			
20190500000788	21097	COMMUNITY BASED PRIMARY HEATH CARE	MUE	Lalbagh	7	CHAIRMAN, MURSHIDABA	22312	CBPHCS	00-8448-00-102-00-001-0-07-00	150004	CBPHCS			

Pay Rs. 1557696 Rupees(in words) Fifteen Lakh Fifty Seven Thousand Six Hundred Ninety Six only as transfer.



Assistant/Accountant

Signature of PULF/PFI/OD Operator



Signature of Joint Signatory

Printed By: DEBARATI DATTA GUPTA

Joint Head, Government of Assam

Page 1 of 1

PAO-III  
Reference Details  
For

Xfer - To Operator List For Personal Ledger Account/Local Fund Account/Provident Fund Account/Other Deposit Account

Operator Code : 19  
Operator Name : DIRECTOR, SUDA

Head of Account : 00-8448-00-120-00-013-0-23-00

Reference Number : 20190500000784

Net Amount : 285888

Reference Date : 30/05/2019

Status : Reference Generated

Sl. No.	Scheme Id	Scheme Description	Payee Treasury Code	Payee Treasury Name	Payee Operator Code	Payee Operator Name	Payee Scheme Id	Payee Scheme Description	Amount	Purpose
1	21097	COMMUNITY BASED	COE	Mekhliganj	2	CHAIRMAN, MEKHLIGANJ	22224	CBPHCS	133356 /	CBPHCS
2	21097	COMMUNITY BASED	COE	Mekhliganj	3	CHAIRMAN, HALDIBARI	22224	CBPHCS	152532 /	CBPHCS

Signature of the Assistant/Accountant

Signature of the Administrator

Signature of Joint Signatory

Printed By : DIPANKAR CHOWDHURY

Printed On : 30/05/2019 4:13 PM

Director  
State Urban Development Agency

Page 1 of 1

PAO-III  
Reference Details

Xfer - To Operator List For Personal Ledger Account/Local Fund Account/Provident Fund Account/Other Deposit Account

Operator Code : 19  
Operator Name : DIRECTOR, SUDA

Head of Account : 00-8448-00-120-00-013-0-23-00

Reference Number : 20190500000785

Net Amount : 268988

Reference Date : 30/05/2019

Status : Reference Generated

Sl. No.	Scheme Id	Scheme Description	Payee Treasury Code	Payee Treasury Name	Payee Operator Code	Payee Operator Name	Payee Scheme Id	Payee Scheme Description	Amount	Purpose
1	21097	COMMUNITY BASED	SPD	Baruipur	7	CHAIRMAN,JOYNA GAR	22181	CBPHCS	268988	CBPHCS

Signature of the Assistant/Accountant

Signature of the Administrator

Signature of Joint Signatory

Printed By : DIPANKAR CHOWDHURY

Printed On : 30/05/2019 4:15 PM

Director  
State Urban Development Agency

Page 1 of 1

PAO-III  
Reference Details

Xfer -To Operator List For Personal Ledger Account/Local Fund Account/Provident Fund Account/Other Deposit Account  
For

Operator Code : 19

Operator Name : DIRECTOR, SUDA

Reference Number : 20190500000786

Reference Date : 30/05/2019

Status : Reference Generated

Head of Account : 00-8448-00-120-00-013-0-23-00

Net Amount :

256488

Sl. No.	Scheme Id	Scheme Description	Payee Treasury Code	Payee Treasury Name	Payee Operator Code	Payee Operator Name	Payee Scheme Id	Payee Scheme Description	Amount	Purpose
1	21097	COMMUNITY BASED	PUC	Jhalda	1	CHAIRMAN, JHALDA	22031	CBPHCS	256488 ✓	CBPHCS

Signature of the Assistant/Accountant

Printed By : DIPANKAR CHOWDHURY

Signature of the Administrator

Printed On : 30/05/2019 4:16 PM

Signature of Joint Signatory

Director  
Joint Urban Development Agency

PAO-III  
Reference Details

For

Xfer -To Operator List For Personal Ledger Account/Local Fund Account/Provident Fund Account/Other Deposit Account

Operator Code : 19  
 Operator Name : DIRECTOR, SUDA  
 Head of Account : 00-8448-00-120-00-013-0-23-00  
 Reference Number : 20190500000787  
 Net Amount : 283788  
 Reference Date : 30/05/2019  
 Status : Reference Generated

Sl. No.	Scheme Id	Scheme Description	Payee Treasury Code	Payee Treasury Name	Payee Operator Code	Payee Operator Name	Payee Scheme Id	Payee Scheme Description	Amount	Purpose
1	21097	COMMUNITY BASED	MIE	Jhargram	9	CHAIRMAN, JHARGRAM	22106	CBPHCS	283788 /	CBPHCS

Signature of the Assistant/Accountant

Printed By : DIPANKAR CHOWDHURY

Signature of the Administrator

Printed On : 30/05/2019 4:17 PM

Signature of Joint Signatory

PAO-III  
Reference Details  
For

Xfer -To Operator List For Personal Ledger Account/Local Fund Account/Provident Fund Account/Other Deposit Account

Operator Code :

19

Head of Account : 00-8448-00-120-00-013-0-23-00

Operator Name :

DIRECTOR, SUDA

Reference Number :

2019050000788

Net Amount :

462544

Reference Date :

30/05/2019

Status :

Reference Generated

Sl. No.	Scheme Id	Scheme Description	Payee Treasury Code	Payee Treasury Name	Payee Operator Code	Payee Operator Name	Payee Scheme Id	Payee Scheme Description	Amount	Purpose
1	21097	COMMUNITY BASED	MUE	Lalbagh	7	CHAIRMAN, MURSHIDABAD	22312	CBPHCS	150004 /	CBPHCS
2	21097	COMMUNITY BASED	MUE	Lalbagh	9	CHAIRMAN, JIAGANJ.	22312	CBPHCS	312540 /	CBPHCS

Signature of the Assistant/Accountant



Signature of the Administrator



Signature of Joint Signatory

Printed By : DIPANKAR CHOWDHURY

Printed On : 30/05/2019 4:20 PM

04-13-2019 11:13:13 AM  
Director  
Joint Signatory

## e-Advice For Personal Ledger Account/Local Fund Account/Provident Fund Account/Other Deposit Account

(For Transfer from one Operator to another Operator)

Operator Code : 9

Operator Designation : DIRECTOR, SUDA

Head of Account : 00-8448-00-120-00-013-0-23-00

Local Advice Id : 25

Memo No. : SUDA-67/2006(PT-3)/16/3698

Local Advice Date : 31/05/2019

Memo Date : 31/05/2019

For use of the Operator												For use of Treasury/PAO	
Reference No.	Details of Payee Operator			Details of Recipient Operator						Amount(Rs.)	Purpose	Approved	Objected
	Scheme Id of Operator	Scheme Description of Operator	Payee Treasury code	Payee Treasury Name	Operator Code of Payee	Designation of Payee Operator	Scheme Id of Payee Operator	Scheme Description of Payee Operator	Head of Account of the Payee Operator				
2019050000789	21097	COMMUNITY BASED PRIMARY HEATH CARE	UDB	Raipur-I	14	Chairman, Kaligarij	22207	CBPHCS	00-8448-00-102-00-001-0-07-00	212206	CBPHCS		
2019050000790	21097	COMMUNITY BASED PRIMARY HEATH CARE	DAC	Kalimpong	4	Chairman, Kalimpong	22140	CBPHCS	00-8448-00-102-00-001-0-07-00	268968	CBPHCS		
2019050000791	21097	COMMUNITY BASED PRIMARY HEATH CARE	BUF	Kalna	7	CHAIRMAN KALNA	21994	CBPHCS	00-8448-00-102-00-001-0-07-00	256488	CBPHCS		
2019050000792	21097	COMMUNITY BASED PRIMARY HEATH CARE	MUD	Kandi	11	CHAIRMAN, K ANDI	22535	CBPHCS	00-8448-00-102-00-001-0-07-00	283788	CBPHCS		
2019050000794	21097	COMMUNITY BASED PRIMARY HEATH CARE	NAA	KrishnaNagar-I	13	Chairman, Krishnagar	22149	CBPHCS/COMMUNITY	00-8448-00-102-00-001-0-07-00	296488	CBPHCS		
2019050000794	21097	COMMUNITY BASED PRIMARY HEATH CARE	NAA	KrishnaNagar-I	3	Nabadwip Municipality	22149	CBPHCS/COMMUNITY	00-8448-00-102-00-001-0-07-00	388414	CBPHCS		

Pay Rs. 1686372 Rupees(in words) Sixteen Lakh Sixty Six Thousand Three Hundred Seventy Two only as transfer.



Assistant/Accountant

Signature of PL/LF/PF/OD Operator



DIRECTOR

Signature of Joint Signatory

Printed By: DEBARATI DATTA GUPTA

Page 1 of 1



PAO-III  
Reference Details

Xfer -To Operator List For Personal Ledger Account/Local Fund Account/Provident Fund Account/Other Deposit Account  
For

Head of Account : 00-8448-00-120-00-013-0-23-00

Operator Code : 19

Operator Name : DIRECTOR, SUDA

Net Amount : 212206

Reference Number : 2019050000789

Reference Date : 30/05/2019

Status : Reference Generated

Sl. No.	Scheme Id	Scheme Description	Payee Treasury Code	Payee Treasury Name	Payee Operator Code	Payee Operator Name	Payee Scheme Id	Payee Scheme Description	Amount	Purpose
1	21097	COMMUNITY BASED	UDB	Raigunji-I	14	Chairman, Kallaganj Municipality, -LF A/C	22207	CBPHCS	212206	CBPHCS

Signature of the Assistant/Accountant

Printed By : DIPANKAR CHOWDHURY

Signature of the Administrator

Printed On : 30/05/2019 4:21 PM

Signature of Joint Signatory

  
Director

Uttarakhand Development Agency

PAO-III  
Reference Details

Xfer - To Operator List For Personal Ledger Account/Local Fund Account/Provident Fund Account/Other Deposit Account

Operator Code : 19  
Operator Name : DIRECTOR, SUDA

Head of Account : 00-8448-00-120-00-013-0-23-00

Reference Number : 20190500000790

Net Amount : 268988

Reference Date : 30/05/2019

Status : Reference Generated

Sl. No.	Scheme Id	Scheme Description	Payee Treasury Code	Payee Treasury Name	Payee Operator Code	Payee Operator Name	Payee Scheme Id	Payee Scheme Description	Amount	Purpose
1	21097	COMMUNITY BASED	DAC	Kalimpong	4	Chairman, Kalimpong	22140	CBPHCS	268988 /	CBPHCS

Signature of the Assistant/Accountant

Signature of the Administrator

Signature of Joint Signatory

Printed By : DIPANKAR CHOWDHURY

Printed On : 30/05/2019 4:23 PM

Director  
Urban Development Agency

PAO-III  
Reference Details

Xfer - To Operator List For Personal Ledger Account/Local Fund Account/Provident Fund Account/Other Deposit Account

Operator Code : 19

Head of Account : 00-8448-00-120-00-013-0-23-00

Operator Name : DIRECTOR, SUDA

Reference Number : 20190500000791

Net Amount : 256488

Reference Date : 30/05/2019

Status : Reference Generated

Sl. No.	Scheme Id	Scheme Description	Payee Treasury Code	Payee Treasury Name	Payee Operator Code	Payee Operator Name	Payee Scheme Id	Payee Scheme Description	Amount	Purpose
1	21097	COMMUNITY BASED	BUF	Kalna	7	CHAIRMAN KALNA MUNICIPALITY	21994	CBPHCS	256488 ✓	CBPHCS

Signature of the Assistant/Accountant



Signature of the Administrator



Signature of Joint Signatory

Printed By : DIPANKAR CHOWDHURY

Printed On : 30/05/2019 4:24 PM

Director  
State Urban Development Agency

PAO-III  
Reference Details

For  
Xfer -To Operator List For Personal Ledger Account/Local Fund Account/Provident Fund Account/Other Deposit Account

Operator Code : 19

Head of Account : 00-8448-00-120-00-013-0-23-00

Operator Name : DIRECTOR, SUDA

Net Amount : 283788

Reference Number : 20190500000792

Reference Date : 30/05/2019

Status : Reference Generated

Sl. No.	Scheme Id	Scheme Description	Payee Treasury Code	Payee Treasury Name	Payee Operator Code	Payee Operator Name	Payee Scheme Id	Payee Scheme Description	Amount	Purpose
1	21097	COMMUNITY BASED	MUD	Kandi	11	CHAIRMAN,KANDI MUNICIPALITY(LF)	22535	CBPHCS	283788 /	CBPHCS

Signature of the Assistant/Accountant



Signature of the Administrator



Signature of Joint Signatory

Printed By : DIPANKAR CHOWDHURY

Printed On : 30/05/2019 4:26 PM

Director  
State Urban Development Agency

PAO-III  
Reference Details

Xfer -To Operator List For Personal Ledger Account/Local Fund Account/Provident Fund Account/Other Deposit Account

Operator Code : 19  
Operator Name : DIRECTOR, SUDA  
Reference Number : 2019050000794  
Reference Date : 30/05/2019  
Status : Reference Generated

Head of Account : 00-8448-00-120-00-013-0-23-00

Net Amount :

644902

Sl. No.	Scheme Id	Scheme Description	Payee Treasury Code	Payee Treasury Name	Payee Operator Code	Payee Operator Name	Payee Scheme Id	Payee Scheme Description	Amount	Purpose
1	21097	COMMUNITY BASED	NAA	KrishnaNagar-I	3	Nabbadwip Municipality	22149	CBPHCS( COMMUNITY BASED PRIMARY HEALTH CARE	388414 /	CBPHCS
2	21097	COMMUNITY BASED	NAA	KrishnaNagar-I	13	Chairman, Krishnagar	22149	CBPHCS( COMMUNITY BASED PRIMARY HEALTH CARE	256488 /	CBPHCS

Signature of the Assistant/Accountant

Printed By : DIPANKAR CHOWDHURY

Signature of the Administrator

Printed On : 30/05/2019 4:41 PM

Director

Signature of Joint Signatory

State Health Development Agency

## e-Advice For Personal Ledger Account/Local Fund Account/Provident Fund Account/Other Deposit Account

(For Transfer from one Operator to another Operator )

Operator Code : 13

Operator Designation : DIRECTOR, SUDA

Head of Account : 00-8448-00-120-00-013-0-23-00

Local Advice Id : 26

Memo No. : SUDA-67/2006(PT-3)/16/3699

Local Advice Date : 31/05/2019

Memo Date : 31/05/2019

For use of the Operator											For use of Treasury/PAO		
Reference No.	Details of Payee Operator		Details of Recipient Operator							Amount(Rs.)	Purpose	Approved	Objected
	Scheme Id of Operator	Scheme Description of Operator	Payee Treasury code	Payee Treasury Name	Operator Code of Payee	Designation of Payee Operator	Scheme Id of Payee Operator	Scheme Description of Payee Operator	Head of Account of the Payee Operator				
20190500000795	21097	COMMUNITY BASED PRIMARY HEATH CARE	DAB	Kurseong	11	Chairman, Kurseong	22527	CBPHCS(HH W)	00-8448-00-102-00-001-0-07-00	296288	CBPHCS		
20190500000796	21097	COMMUNITY BASED PRIMARY HEATH CARE	JAD	Mal	4	CHAIRMAN . MAL	22214	CBPHCS	00-8448-00-102-00-001-0-07-00	288184	CBPHCS		
20190500000797	21097	COMMUNITY BASED PRIMARY HEATH CARE	GOD	Mathabhanga	14	Chairman, Mathabhanga	22133	CBPHCS	00-8448-00-102-00-001-0-07-00	225236	CBPHCS		
20190500000798	21097	COMMUNITY BASED PRIMARY HEATH CARE	MIA	Midnapore	25	CHAIRMAN MIDNAPORE	22304	CBPHCS	00-8448-00-102-00-001-0-07-00	353660	CBPHCS		
20190500000799	21097	COMMUNITY BASED PRIMARY HEATH CARE	DAF	Mirk	1	CHAIRMAN MIRIK	22454	CBPHCS	00-8448-00-102-00-001-0-07-00	207938	CBPHCS		

Pay Rs. 1371284 Rupees(in words) Thirteen Lakh Seventy One Thousand Two Hundred Eighty Four only as transfer.

Assistant/Accountant

Signature of PL/LF/PF/OD Operator

Signature of Joint Signatory

Printed By: DEBARATI DATTA GUPTA

  
**Director**  
 State Urban Development Agency

Page 1 of 1

PAO-III  
Reference Details

Xier -To Operator List For Personal Ledger Account/Local Fund Account/Provident Fund Account/Other Deposit Account

Operator Code : 19  
Operator Name : DIRECTOR, SUDA

Head of Account : 00-8448-00-120-00-013-0-23-00

Reference Number : 20190500000795

Net Amount : 296288

Reference Date : 30/05/2019

Status : Reference Generated

Sl. No.	Scheme Id	Scheme Description	Payee Treasury Code	Payee Treasury Name	Payee Operator Code	Payee Operator Name	Payee Scheme Id	Payee Scheme Description	Amount	Purpose
1	21097	COMMUNITY BASED	DAB	Kurseong	11	Chairman, Kurseong Municipality	22527	CBPHCS(HHW)	296288 /	CBPHCS

Signature of the Assistant/Accountant

Printed By : DIPANKAR CHOWDHURY

Signature of the Administrator

Printed On : 30/05/2019 4:43 PM

Signature of Joint Signatory

Director

State Urban Development Agency

PAO-III  
Reference Details

For  
Xier -To Operator List For Personal Ledger Account/Local Fund Account/Provident Fund Account/Other Deposit Account

Operator Code : 19

Head of Account : 00-8448-00-120-00-013-0-23-00

Operator Name : DIRECTOR, SUDA

Reference Number : 2019050000796

Net Amount : 288164

Reference Date : 30/05/2019

Status : Reference Generated

Sl. No.	Scheme Id	Scheme Description	Payee Treasury Code	Payee Treasury Name	Payee Operator Code	Payee Operator Name	Payee Scheme Id	Payee Scheme Description	Amount	Purpose
1	21097	COMMUNITY BASED	JAD	Mal	4	CHAIRMAN , MAL MUNICIPALITY	22214	CBPHCS	288164 ✓	CBPHCS

Signature of the Assistan/Accountant

Signature of the Administrator

Signature of Joint Signatory

Printed By : DIPANKAR CHOWDHURY

Printed On : 30/05/2019 4:45 PM

State Urban Development Agency

Page 1 of 1



PAO-III  
Reference Details

Xfer - To Operator List For Personal Ledger Account/Local Fund Account/Provident Fund Account/Other Deposit Account

Operator Code : 19  
Operator Name : DIRECTOR, SUDA

Head of Account : 00-8448-00-120-00-013-0-23-00

Reference Number : 20190500000797

Net Amount : 225236

Reference Date : 30/05/2019

Status : Reference Generated

Sl. No.	Scheme Id	Scheme Description	Payee Treasury Code	Payee Treasury Name	Payee Operator Code	Payee Operator Name	Payee Scheme Id	Payee Scheme Description	Amount	Purpose
1	21097	COMMUNITY BASED	COD	Mathabhanga	14	Chairman, Mathabhanga	22133	CBPHCS	225236 /	CBPHCS

Signature of the Assistant/Accountant



Signature of the Administrator



Signature of Joint Signatory

Printed By : DIPANKAR CHOWDHURY

Printed On : 30/05/2019 4:46 PM

State Urban Development Agency

Director

PAO-III  
Reference Details

Xfer -To Operator List For Personal Ledger Account/Local Fund Account/Provident Fund Account/Other Deposit Account

Operator Code : 19  
Operator Name : DIRECTOR, SUDA  
Head of Account : 00-8448-00-120-00-013-0-23-00

Reference Number : 20190500000798  
Net Amount : 353660

Reference Date : 30/05/2019

Status : Reference Generated

Sl. No.	Scheme Id	Scheme Description	Payee Treasury Code	Payee Treasury Name	Payee Operator Code	Payee Operator Name	Payee Scheme Id	Payee Scheme Description	Amount	Purpose
1	21097	COMMUNITY BASED	MIA	Midnapore	25	CHAIRMAN MIDNAPORE	22304	CBPHCS	353660 ✓	CBPHCS

Signature of the Assistant/Accountant



Printed By : DIPANKAR CHOWDHURY

Signature of the Administrator

Printed On : 30/05/2019 4:47 PM

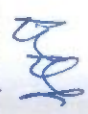

Director

Signature of Joint Signatory

Oriss Urban Development Agency

PAO-III  
Reference Details  
For

Xfer -To Operator List For Personal Ledger Account/Local Fund Account/Provident Fund Account/Other Deposit Account

Operator Code : 19  
Operator Name : DIRECTOR, SUDA

Head of Account : 00-8448-00-120-00-013-0-23-00

Reference Number : 20190500000799

Net Amount :

207936

Reference Date : 30/05/2019

Status : Reference Generated

Sl. No.	Scheme Id	Scheme Description	Payee Treasury Code	Payee Treasury Name	Payee Operator Code	Payee Operator Name	Payee Scheme Id	Payee Scheme Description	Amount	Purpose
1	21097	COMMUNITY BASED	DAF	Mirik	1	CHAIRMAN MIRIK MUNICIPALITY	22454	CBPHCS	207936 ✓	CBPHCS

Signature of the Assistant/Accountant



Printed By : DIPANKAR CHOWDHURY

Signature of the Administrator



Printed On : 30/05/2019 4:49 PM

Director

State Urban Development Agency

Signature of Joint Signatory

## e-Advice For Personal Ledger Account/Local Fund Account/Provident Fund Account/Other Deposit Account

(For Transfer from one Operator to another Operator )

Operator Code : 19

Operator Designation : DIRECTOR, SUDA

Head of Account : 00-8448-00-120-00-013-0-23-00

Local Advice Id : 27

Memo No. : SUDA-67/2006(PT-3)/16/3700

Local Advice Date : 31/05/2019

Memo Date : 31/05/2019

For use of the Operator												For use of Treasury/PAO		
Reference No.	Details of Payee Operator			Details of Recipient Operator							Amount(Rs.)	Purpose	Approved	Objected
	Scheme Id of Operator	Scheme Description of Operator	Payee Treasury code	Payee Treasury Name	Operator Code of Payee	Designation of Payee Operator	Scheme Id of Payee Operator	Scheme Description of Payee Operator	Head of Account of the Payee Operator					
20190500000800	21097	COMMUNITY BASED PRIMARY HEATH CARE	BRC	Rampurhat	11	CHAIRMAN, NALHATI	22086	CBPHCS	00-8448-00-102-00-001-0-07-00	224210	CBPHCS			
20190500000800	21097	COMMUNITY BASED PRIMARY HEATH CARE	BRC	Rampurhat	10	CHAIRMAN, RAMPURHAT	22086	CBPHCS	00-8448-00-102-00-001-0-07-00	196780	CBPHCS			
20190500000801	21097	COMMUNITY BASED PRIMARY HEATH CARE	MOB	Malda-II	3	CHAIRMAN, OLD MALDA	22176	CBPHCS	00-8448-00-102-00-001-0-07-00	214208	CBPHCS			
20190500000802	21097	COMMUNITY BASED PRIMARY HEATH CARE	MIG	Tamluk	26	Panskura Municipality	22089	CBPHCS	00-8448-00-102-00-001-0-07-00	264414	CBPHCS			
20190500000802	21097	COMMUNITY BASED PRIMARY HEATH CARE	MIG	Tamluk	36	Chairman, Tamluk	22089	CBPHCS	00-8448-00-102-00-001-0-07-00	319214	CBPHCS			
20190500000803	21097	COMMUNITY BASED PRIMARY HEATH CARE	PUA	Purulia	20	CHAIRMAN PURULIA	22377	CBPHCS	00-8448-00-102-00-001-0-07-00	270558	CBPHCS			
20190500000804	21097	COMMUNITY BASED PRIMARY HEATH CARE	PUB	Raghunathpur	7	Chairman, Raghunathpur	22112	CBPHCS	00-8448-00-102-00-001-0-07-00	223560	CBPHCS			

Pay Rs. 1742944 Rupees(in words) Seventeen Lakh Forty Two Thousand Nine Hundred Forty Four only as transfer.



Assistant/Accountant

Signature of PULF/PFIOD Operator



Director

State Urban Development Agency

Signature of Joint Signatory

Printed By: DEBARATI DATTA GUPTA

Page 1 of 1

PAO-III  
Reference Details

Xfer -To Operator List For Personal Ledger Account/Local Fund Account/Provident Fund Account/Other Deposit Account  
For

Operator Code : 19

Operator Name : DIRECTOR, SUDA

Head of Account : 00-8448-00-120-00-013-0-23-00

Reference Number : 20190500000800

Reference Date : 30/05/2019

Net Amount : 420990

Status : Reference Generated

Sl. No.	Scheme Id	Scheme Description	Payee Treasury Code	Payee Treasury Name	Payee Operator Code	Payee Operator Name	Payee Scheme Id	Payee Scheme Description	Amount	Purpose
1	21097	COMMUNITY BASED	BRC	Rampurhat	10	CHAIRMAN, RAMPURHAT	22086	CBPHCS	196780 /	CBPHCS
2	21097	COMMUNITY BASED	BRC	Rampurhat	11	CHAIRMAN, NALHATI	22086	CBPHCS	224210 /	CBPHCS

Signature of the Assistant/Accountant

Printed By : DIPANKAR CHOWDHURY

Signature of the Administrator

Printed On : 30/05/2019 4:51 PM

*[Signature]*  
Director

State Urban Development Agency

Signature of Joint Signatory

PAO-III

Reference Details

For

Xfer -To Operator List For Personal Ledger Account/Local Fund Account/Provident Fund Account/Other Deposit Account

Operator Code : 19

Operator Name : DIRECTOR, SUDA

Head of Account : 00-8448-00-120-00-013-0-23-00

Reference Number : 20190500000801

Net Amount : 214208

Reference Date : 30/05/2019

Status : Reference Generated

Sl. No.	Scheme Id	Scheme Description	Payee Treasury Code	Payee Treasury Name	Payee Operator Code	Payee Operator Name	Payee Scheme Id	Payee Scheme Description	Amount	Purpose
1	21097	COMMUNITY BASED	MDB	Malda-II	3	CHAIRMAN, OLD MALDA	22176	CBPHCS	214208 /	CBPHCS



Signature of the Assistant/Accountant

Printed By : DIPANKAR CHOWDHURY



Director

Signature of the Administrator

Printed On : 30/05/2019 4:52 PM

Signature of Joint Signatory

State Urban Development Agency

PAO-III  
Reference Details

For

Xfer -To Operator List For Personal Ledger Account/Local Fund Account/Provident Fund Account/Other Deposit Account

Operator Code : 19

Head of Account : 00-8448-00-120-00-013-0-23-00

Operator Name : DIRECTOR, SUDA

Reference Number : 2019050000802

Net Amount : 613628

Reference Date : 30/05/2019

Status : Reference Generated

Sl. No.	Scheme Id	Scheme Description	Payee Treasury Code	Payee Treasury Name	Payee Operator Code	Payee Operator Name	Payee Scheme Id	Payee Scheme Description	Amount	Purpose
1	21097	COMMUNITY BASED	MIG	Tamiluk	36	Chairman, Tamiluk Municipality(	22069	CBPHCS	319214 /	CBPHCS
2	21097	COMMUNITY BASED	MIG	Tamiluk	26	Panskura Municipality (8448)	22069	CBPHCS	294414 /	CBPHCS

Signature of the Assistant/Accountant



Signature of the Administrator



Signature of Joint Signatory

Director

Printed By : DIPANKAR CHOWDHURY

Printed On : 30/05/2019 4:54 PM

State Urban Development Agency

Page 1 of 1

PAO-III

Reference Details

For

Xfer -To Operator List For Personal Ledger Account/Local Fund Account/Provident Fund Account/Other Deposit Account

Operator Code : 19

Operator Name : DIRECTOR, SUDA

Head of Account : 00-8448-00-120-00-013-0-23-00

Reference Number : 20190500000803

Net Amount : 270558

Reference Date : 30/05/2019

Status : Reference Generated

Sl. No.	Scheme Id	Scheme Description	Payee Treasury Code	Payee Treasury Name	Payee Operator Code	Payee Operator Name	Payee Scheme Id	Payee Scheme Description	Amount	Purpose
1	21097	COMMUNITY BASED	PUA	Purulia	20	CHAIRMAN PURULIA	22377	CBPHCS	270558 /	CBPHCS

Signature of the Assistant/Accountant



Signature of the Administrator



Signature of Joint Signatory

Printed By : DIPANKAR CHOWDHURY

Printed On : 30/05/2019 4:56 PM

Director

Page 1 of 1

State Urban Development Agency